

D CIRCUIT DIAGRAM BY FUNCTION

POWER SOURCE -----	D - 1	RHD VEHICLE -----	D - 149
RHD VEHICLE -----	D - 1	LHD VEHICLE-----	D - 153
LHD VEHICLE -----	D - 7	FOG LAMP-----	D - 157
STARTING SYSTEM-----	D - 13	RHD VEHICLE -----	D - 157
RHD VEHICLE -----	D - 13	LHD VEHICLE-----	D - 161
LHD VEHICLE -----	D - 17	HAZARD WARNING & TURN SIGNAL	
CHARGING SYSTEM -----	D - 21	LAMP -----	D - 165
RHD VEHICLE -----	D - 21	RHD VEHICLE -----	D - 165
LHD VEHICLE -----	D - 25	LHD VEHICLE-----	D - 169
ENGINE CONTROL SYSTEM -----	D - 29	STOP LAMP-----	D - 173
RHD VEHICLE(1KR-FE ENGINE)-----	D - 29	RHD VEHICLE -----	D - 173
LHD VEHICLE(1KR-FE ENGINE) -----	D - 35	LHD VEHICLE-----	D - 177
RHD VEHICLE(K3-VE ENGINE)-----	D - 41	TAIL & LICENSE PLATE LAMP -----	D - 181
LHD VEHICLE(K3-VE ENGINE) -----	D - 47	RHD VEHICLE -----	D - 181
RADIATOR FAN-----	D - 53	LHD VEHICLE-----	D - 185
RHD VEHICLE -----	D - 53	BACK UP LAMP-----	D - 189
LHD VEHICLE -----	D - 57	RHD VEHICLE -----	D - 189
ABS-----	D - 61	LHD VEHICLE-----	D - 193
RHD VEHICLE -----	D - 61	FRONT WIPER & WASHER -----	D - 197
LHD VEHICLE -----	D - 65	RHD VEHICLE -----	D - 197
A/T CONTROL-----	D - 69	LHD VEHICLE-----	D - 201
RHD VEHICLE -----	D - 69	REAR WIPER & WASHER -----	D - 201
LHD VEHICLE -----	D - 73	RHD VEHICLE(WITH INT SYSTEM) D - 205	
ELECTRIC POWER STEERING -----	D - 77	RHD VEHICLE(WITHOUT INT	
RHD VEHICLE -----	D - 77	SYSTEM) -----	D - 209
LHD VEHICLE -----	D - 81	LHD VEHICLE(WITH INT SYSTEM)-	D - 213
SRS AIRBAG SYSTEM -----	D - 85	LHD VEHICLE(WITHOUT INT	
RHD VEHICLE -----	D - 85	SYSTEM) -----	D - 217
LHD VEHICLE -----	D - 89	RADIO-----	D - 221
DOME LAMP -----	D - 93	RHD VEHICLE -----	D - 221
RHD VEHICLE -----	D - 93	LHD VEHICLE-----	D - 225
LHD VEHICLE -----	D - 97	HORN -----	D - 229
POWER DOOR LOCK,KEY-LESS		RHD VEHICLE -----	D - 229
ENTRY SYSTEM-----	D - 101	LHD VEHICLE-----	D - 233
RHD VEHICLE -----	D - 101	CIGARETTE LIGHTER,POWER	
LHD VEHICLE-----	D - 105	OUTLET -----	D - 237
IMMOBILIZER SYSTEM -----	D - 109	RHD VEHICLE -----	D - 237
RHD VEHICLE -----	D - 109	LHD VEHICLE-----	D - 239
LHD VEHICLE-----	D - 113	HEATER & AIR CONDITIONER -----	D - 241
OUTER REAR-VIEW MIRROR-----	D - 117	RHD VEHICLE -----	D - 241
RHD VEHICLE -----	D - 117	LHD VEHICLE-----	D - 245
LHD VEHICLE-----	D - 121	DATA LINK CONNECTOR-----	D - 249
REAR WINDOW DEFOGGER-----	D - 125	RHD VEHICLE -----	D - 249
RHD VEHICLE -----	D - 125	LHD VEHICLE -----	D - 253
LHD VEHICLE-----	D - 129		
POWER WINDOW-----	D - 133		
RHD VEHICLE -----	D - 133		
LHD VEHICLE-----	D - 137		
METER-----	D - 141		
RHD VEHICLE -----	D - 141		
LHD VEHICLE-----	D - 145		
HEAD LAMP-----	D - 149		

1 POWER SOURCE 1-1 RHD VEHICLE

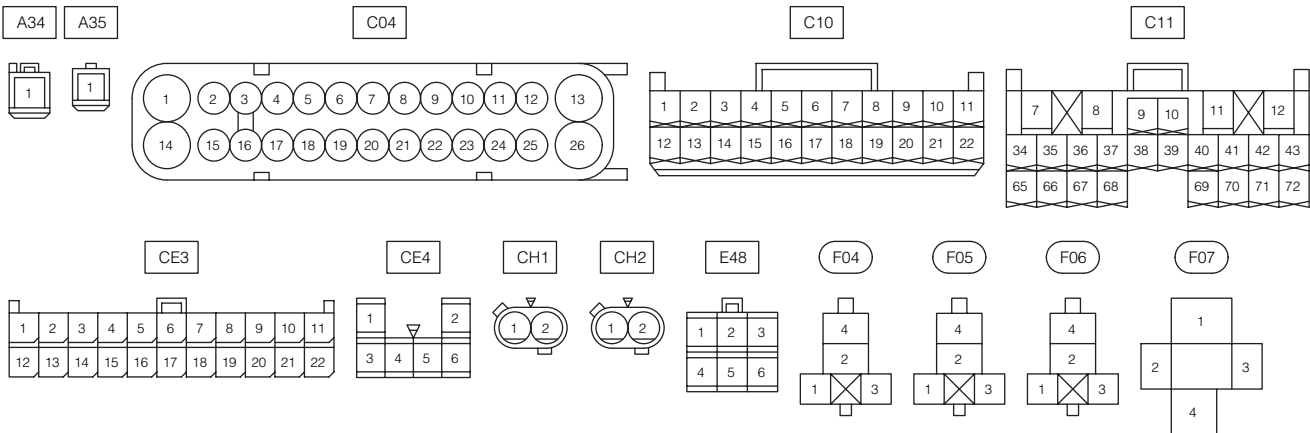

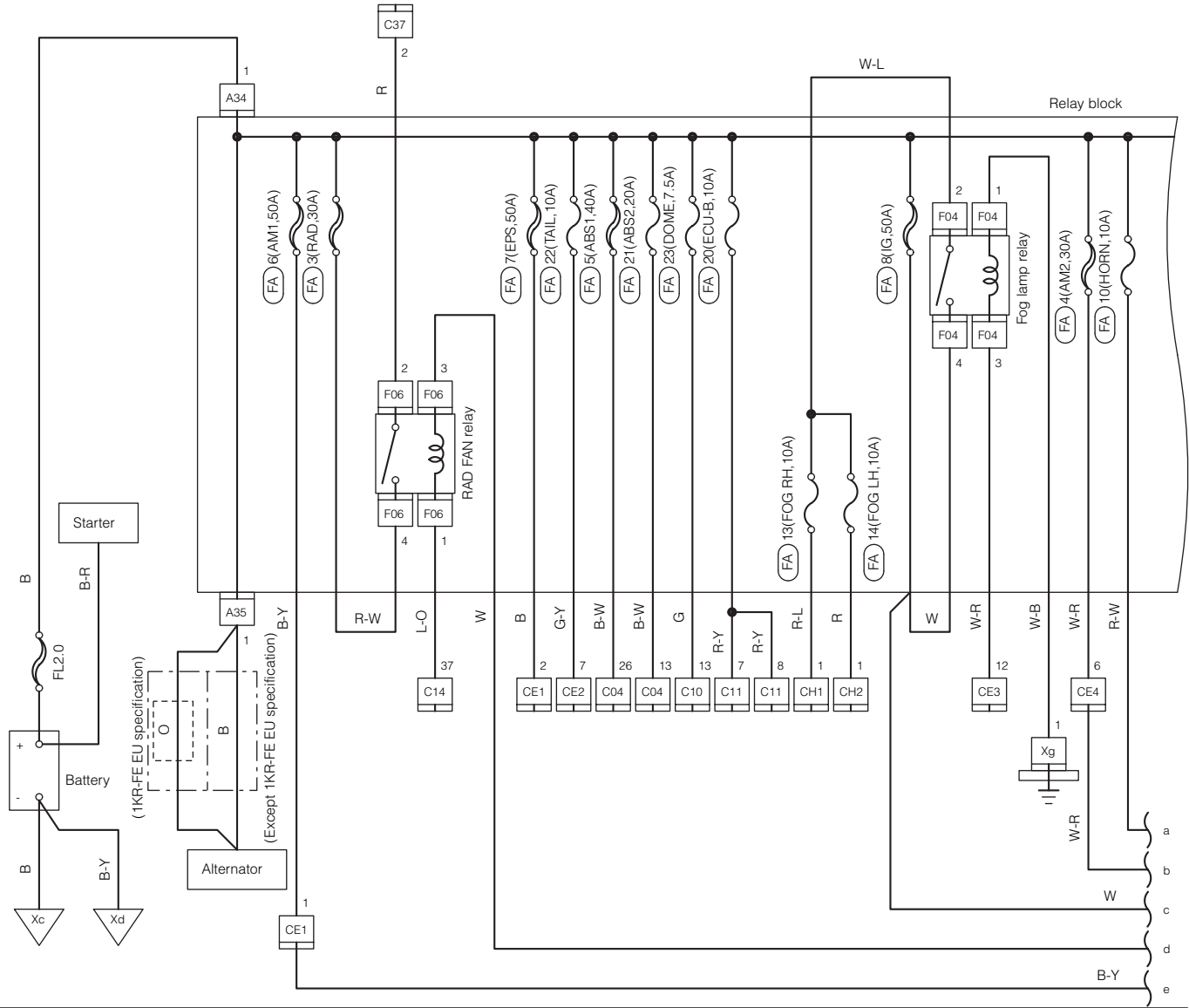
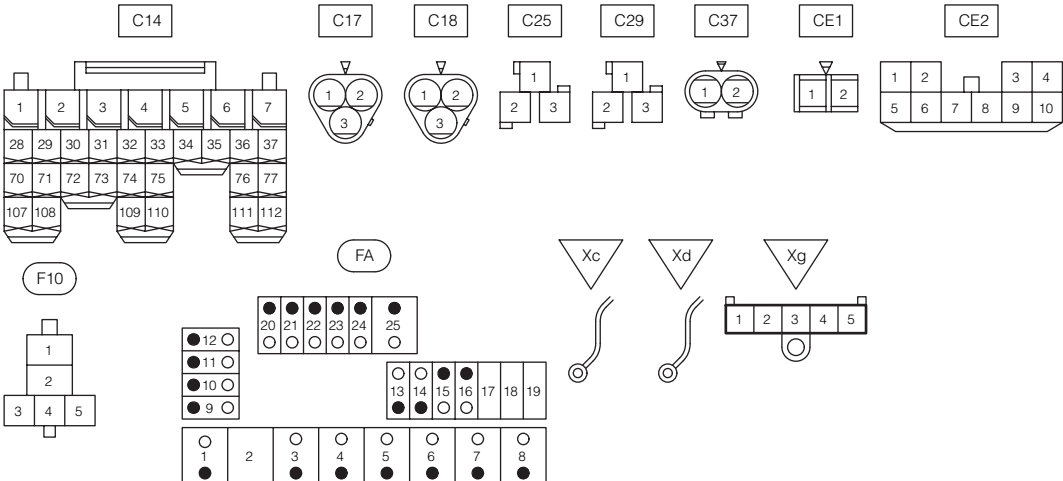
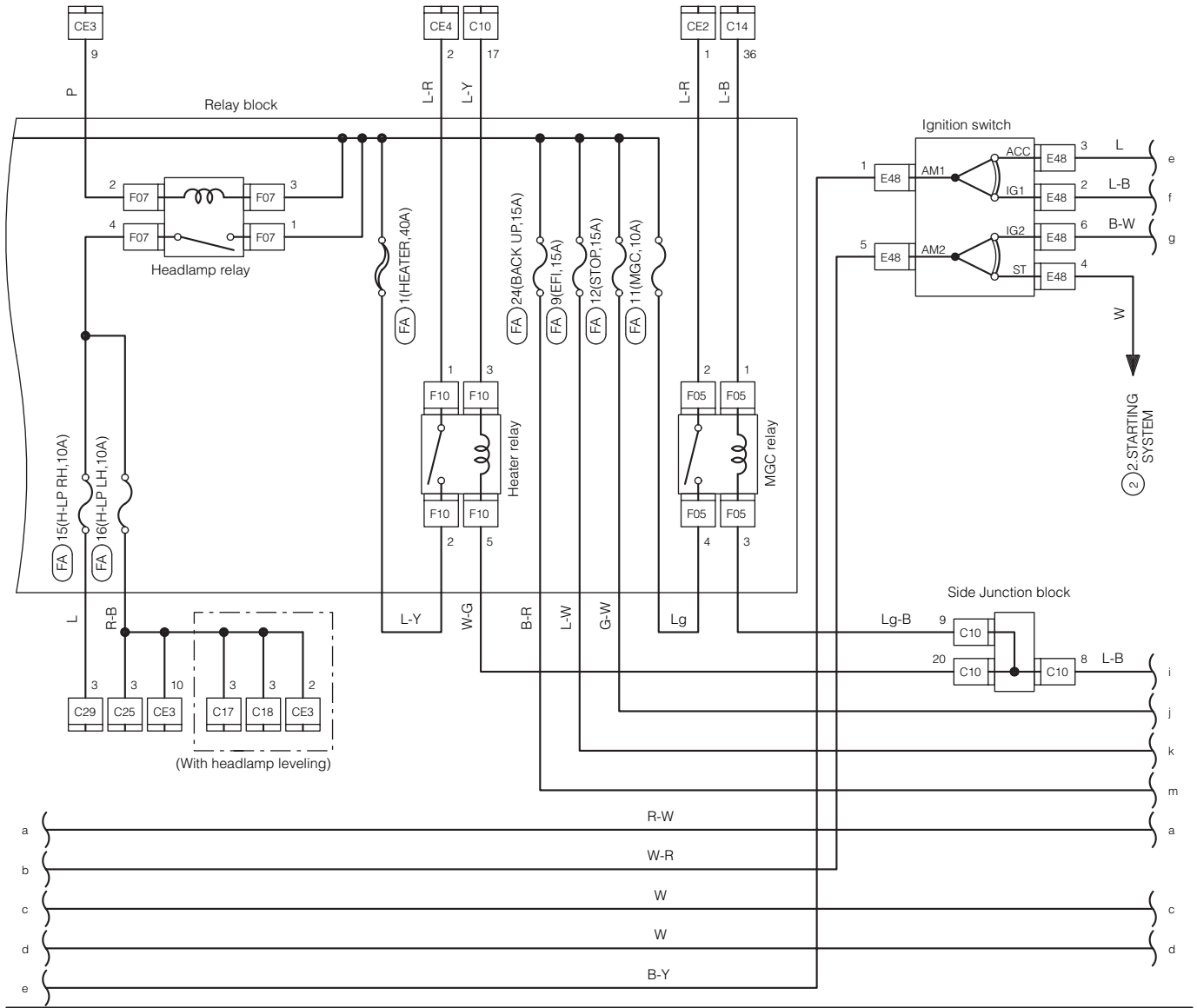

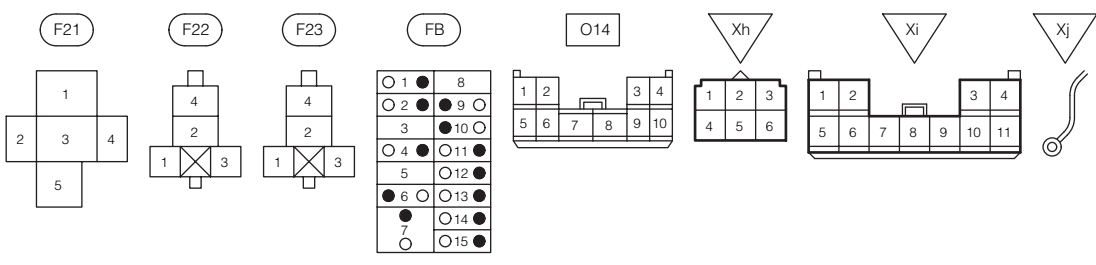
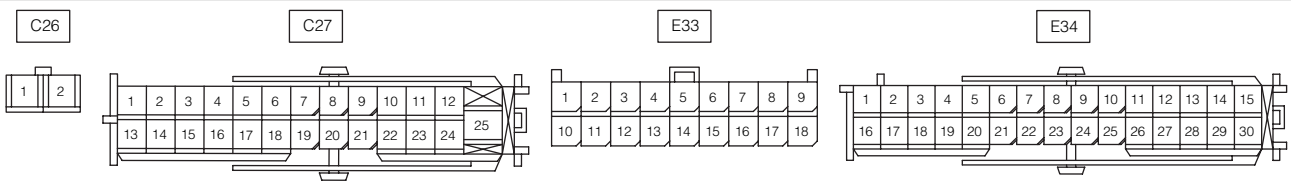
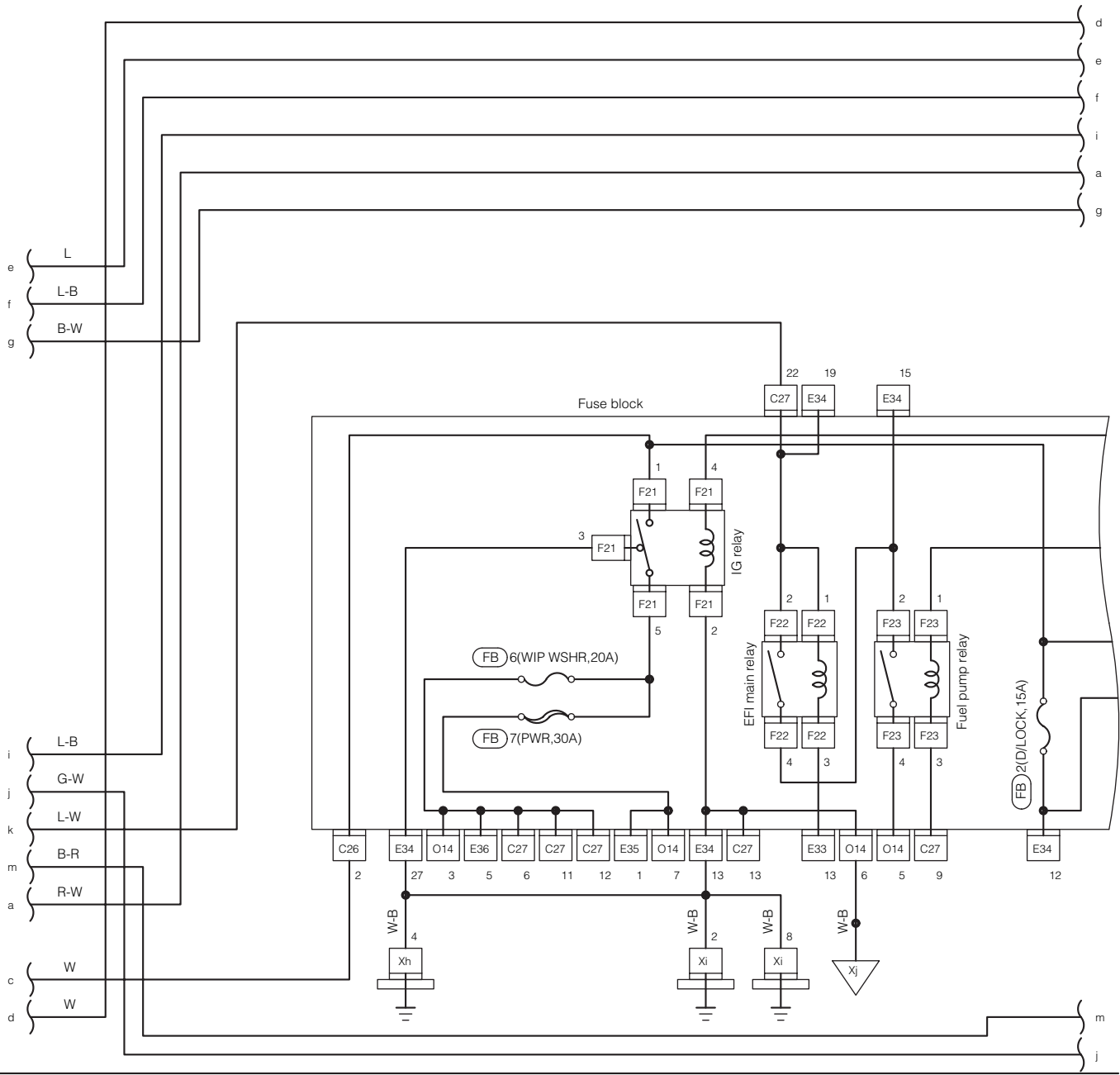

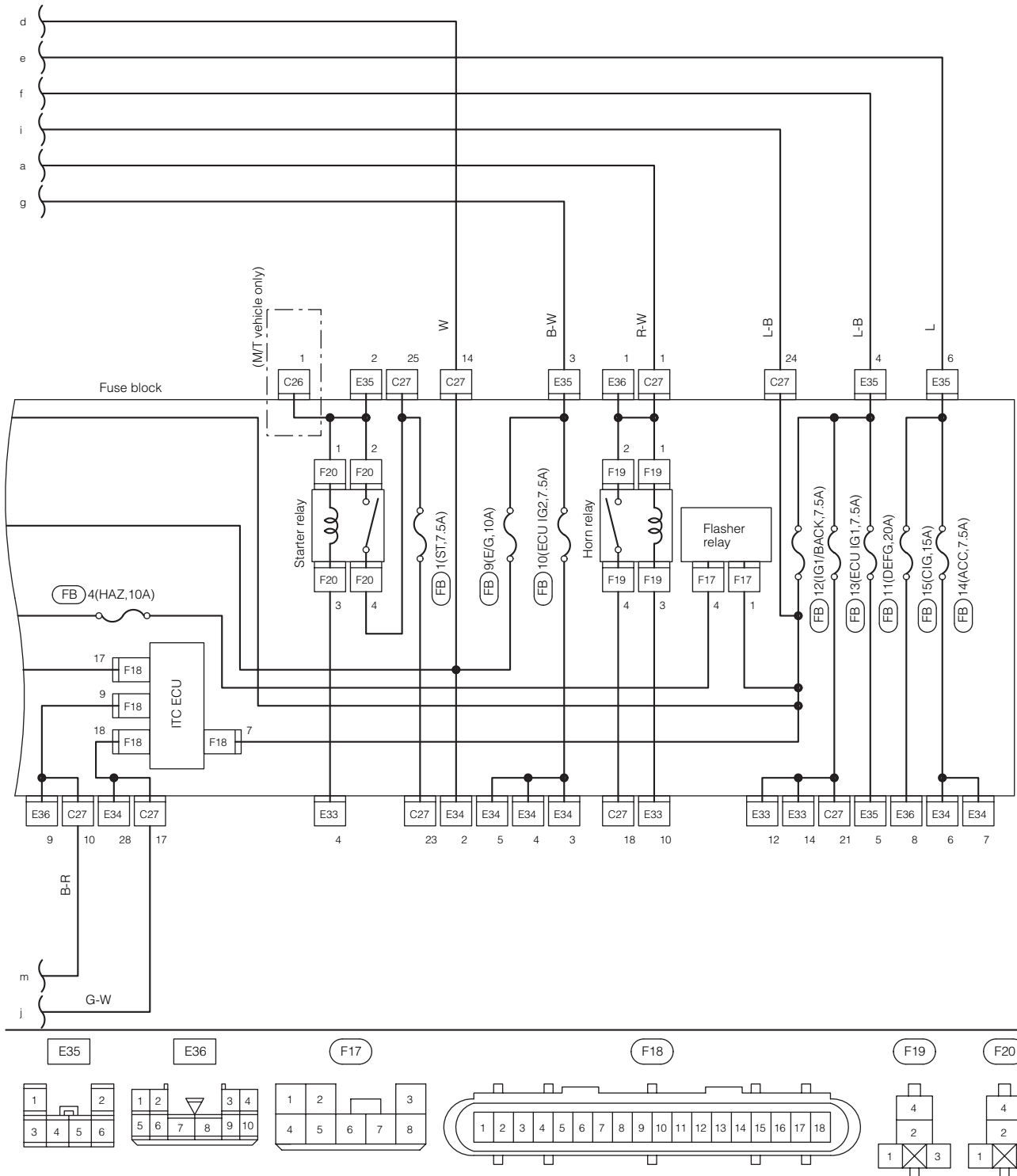

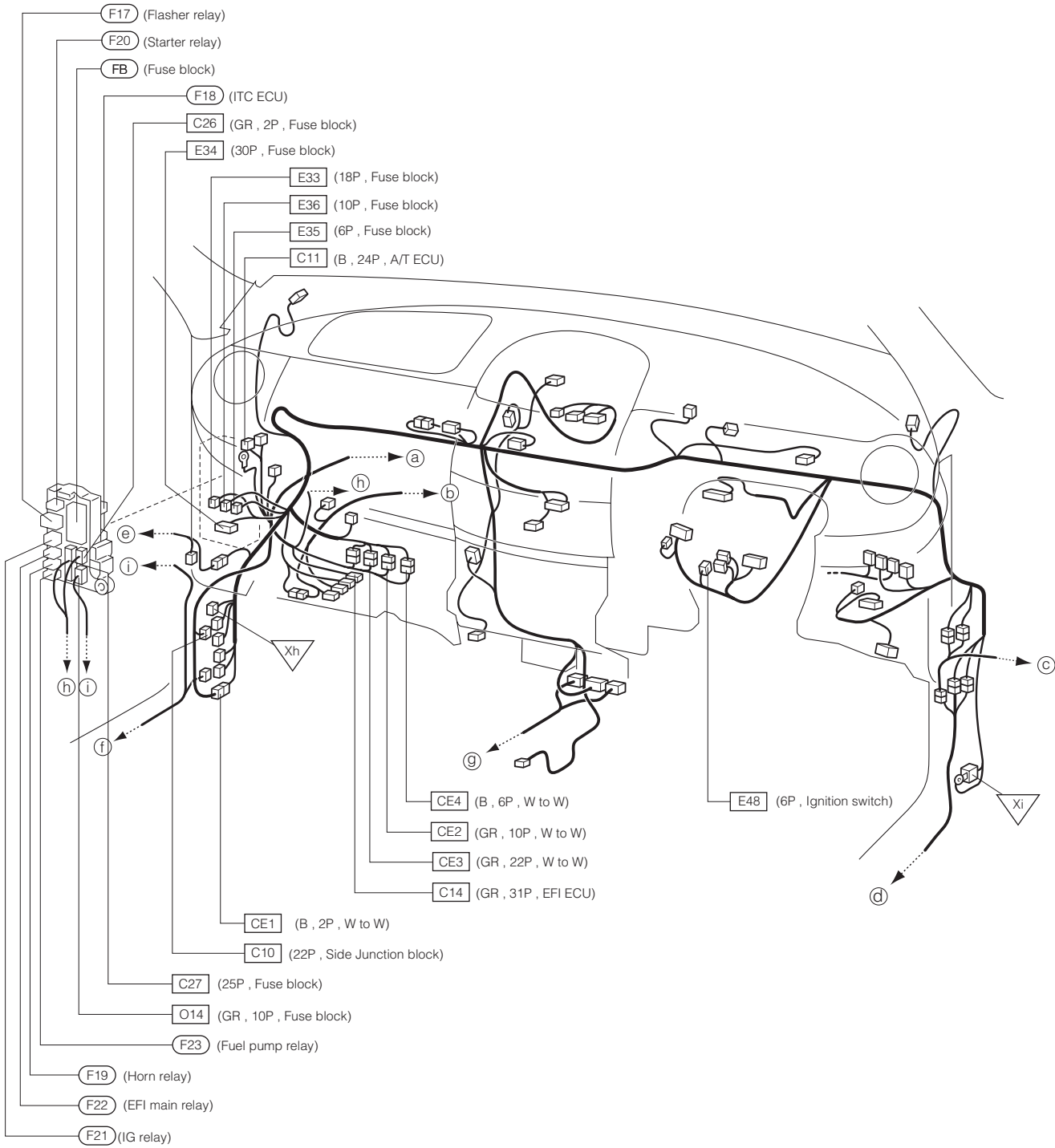

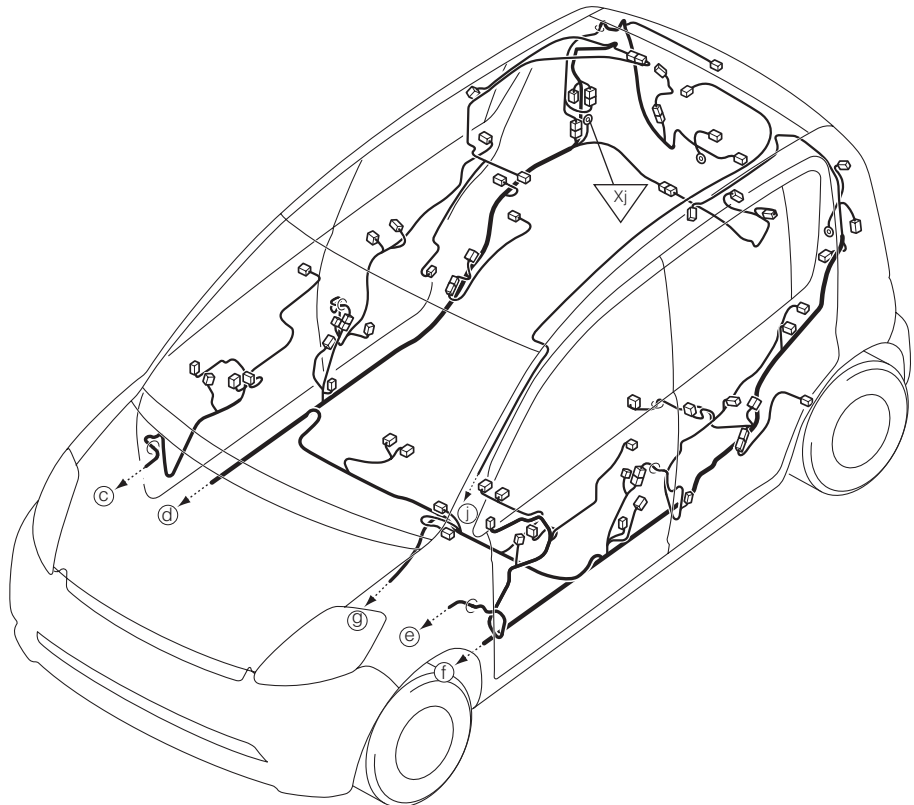
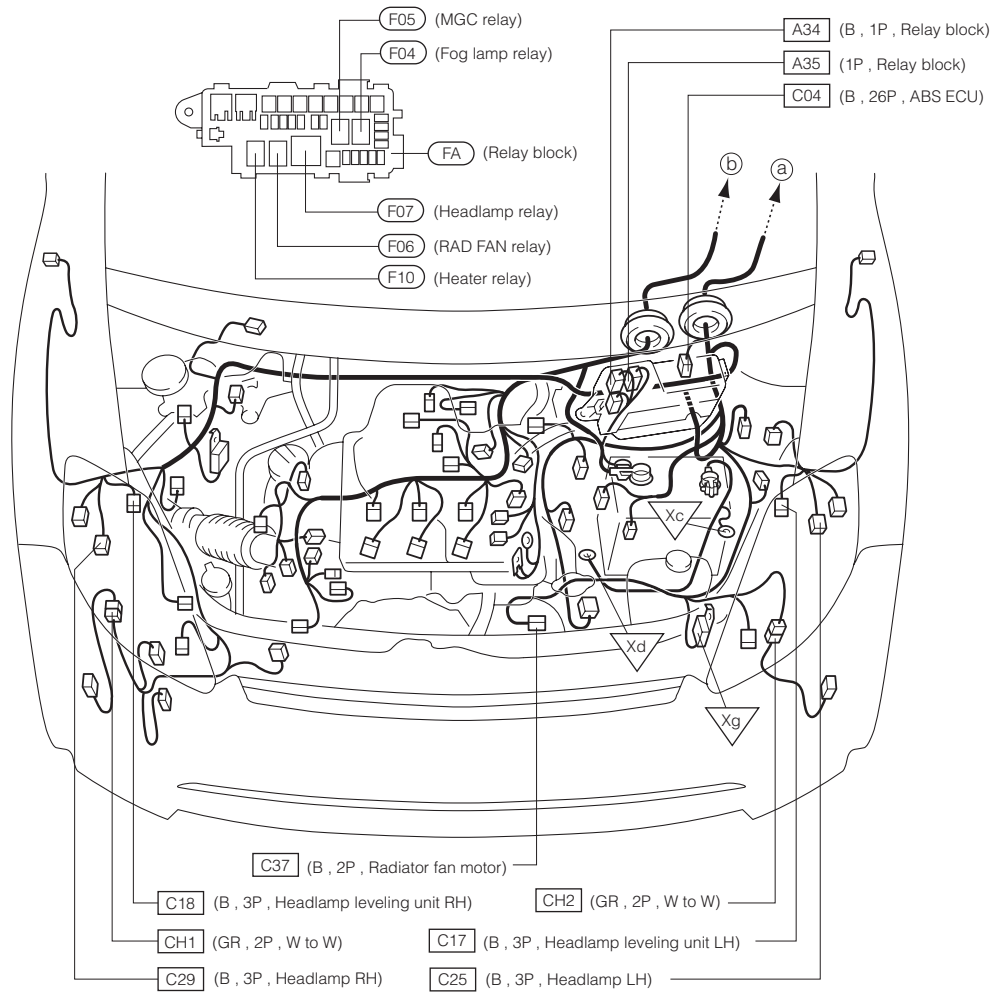

1-2 LHD VEHICLE

*1:1KR-FE
*2:K3-VE

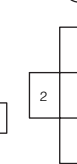
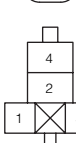
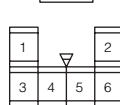
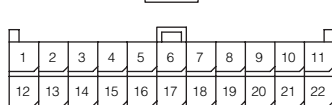
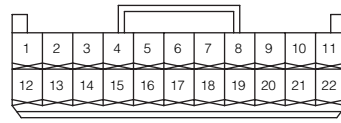
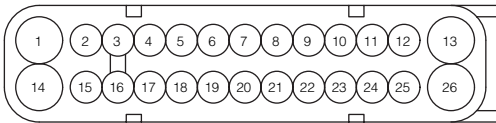
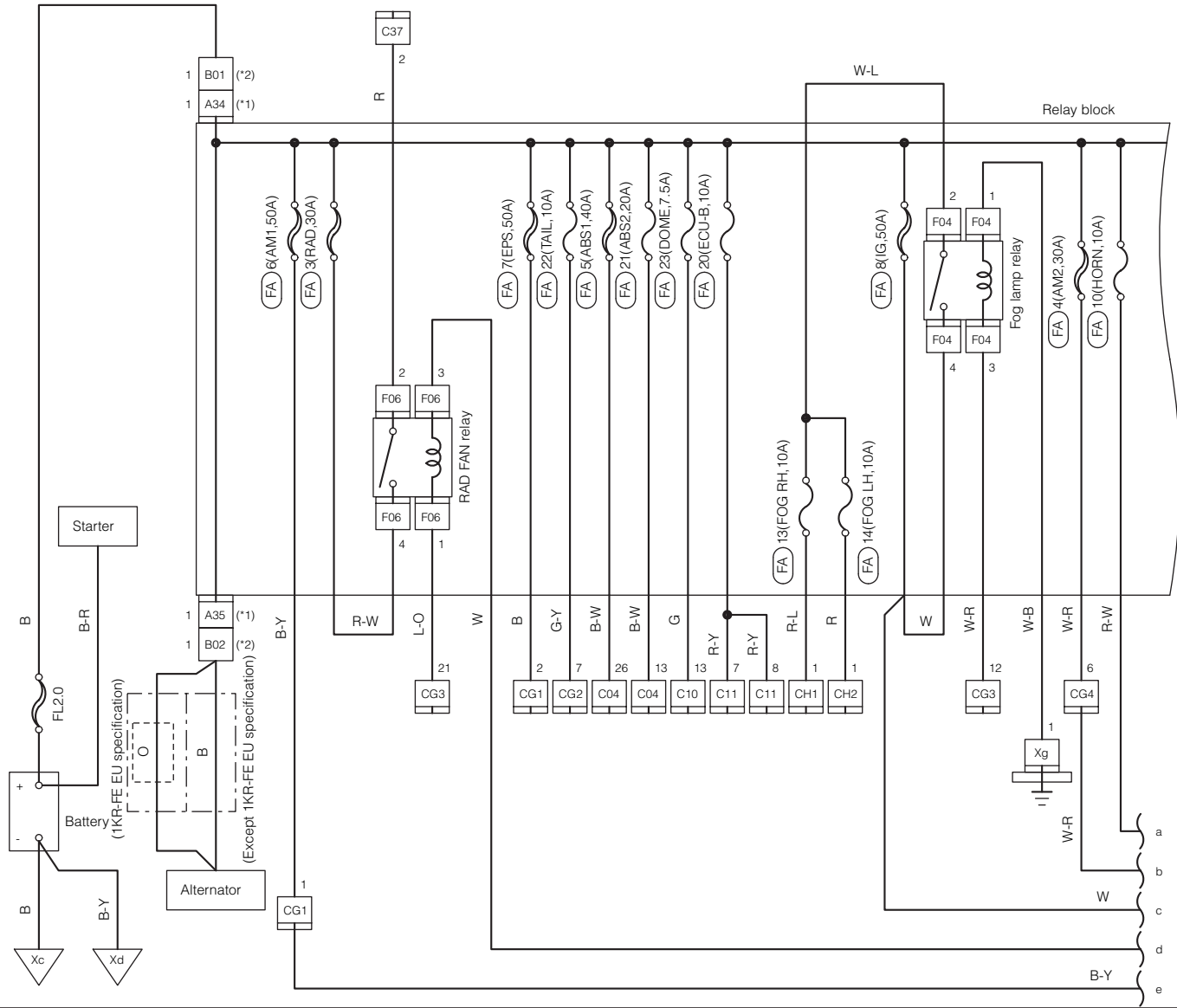

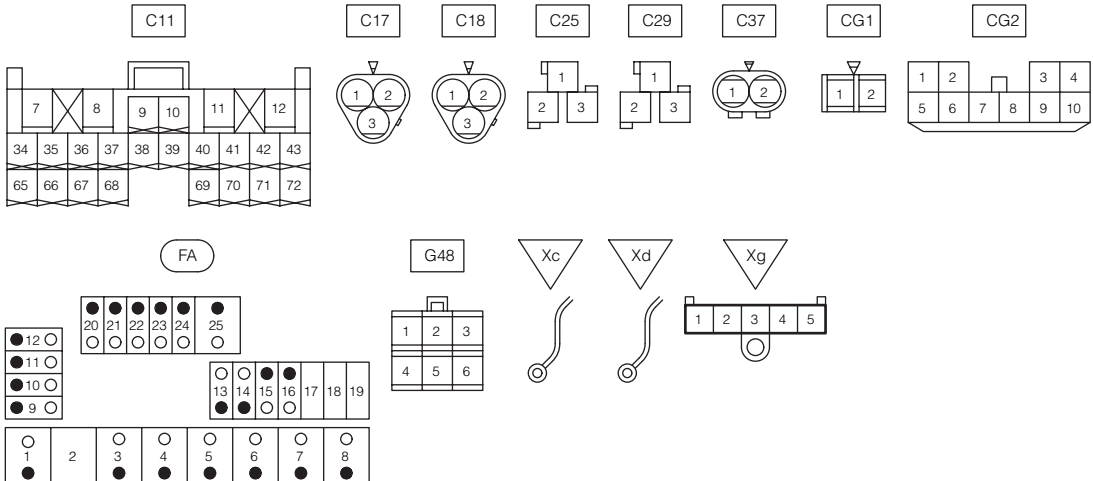
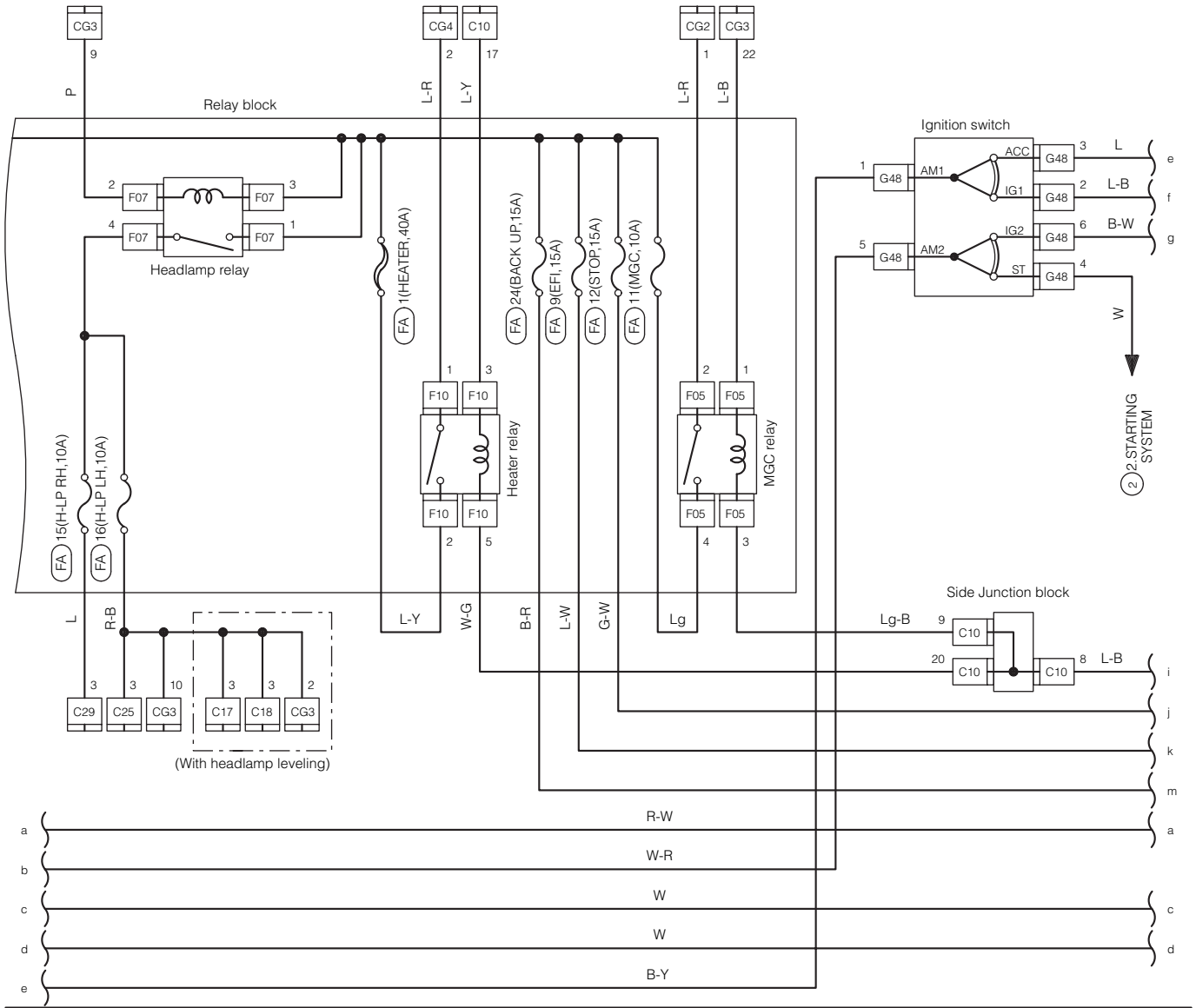

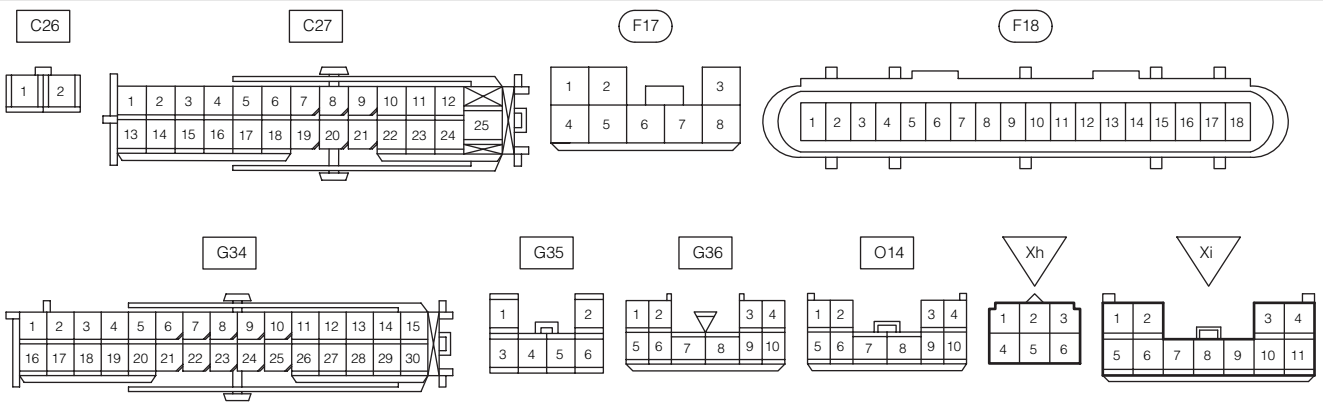
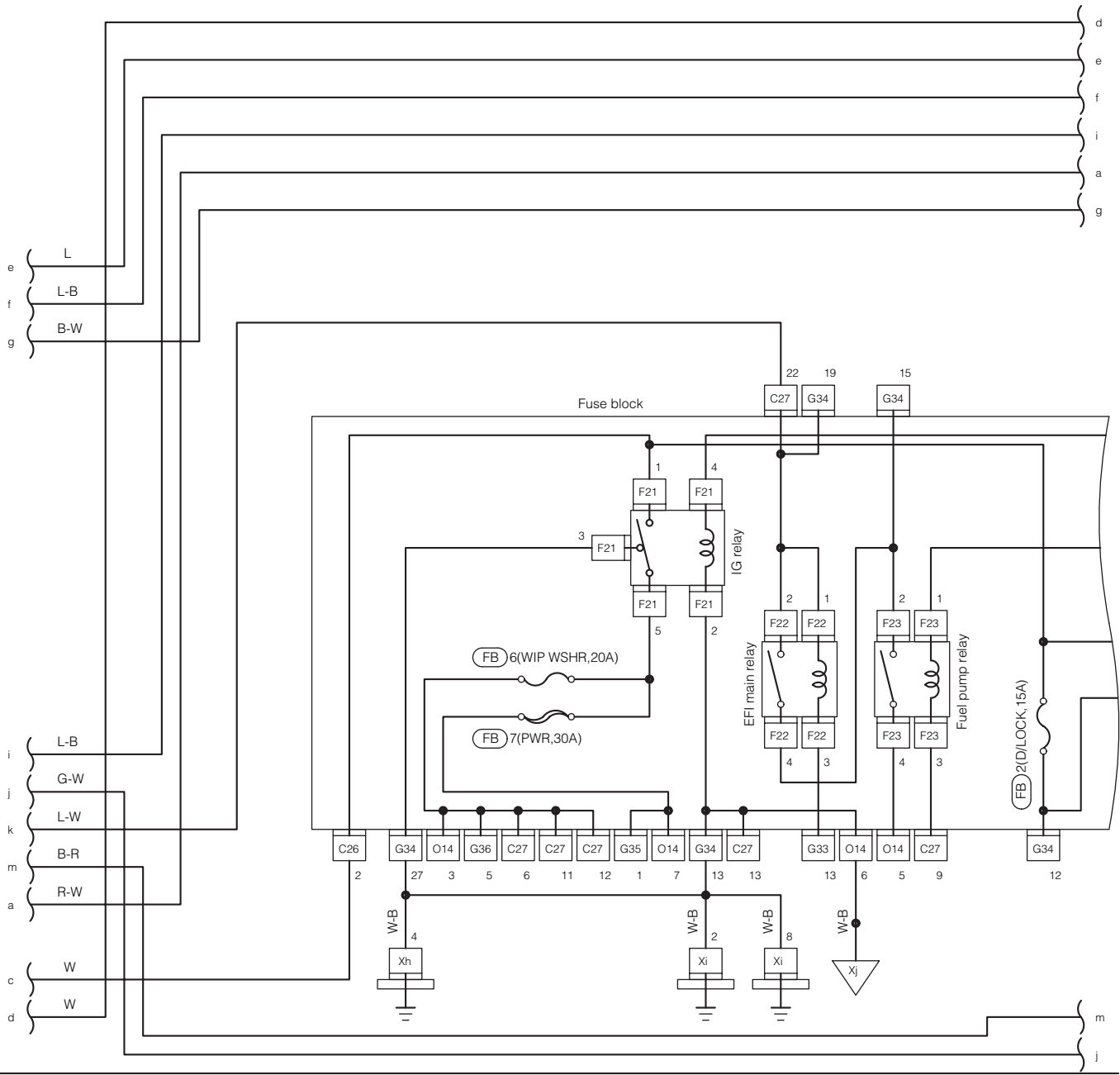

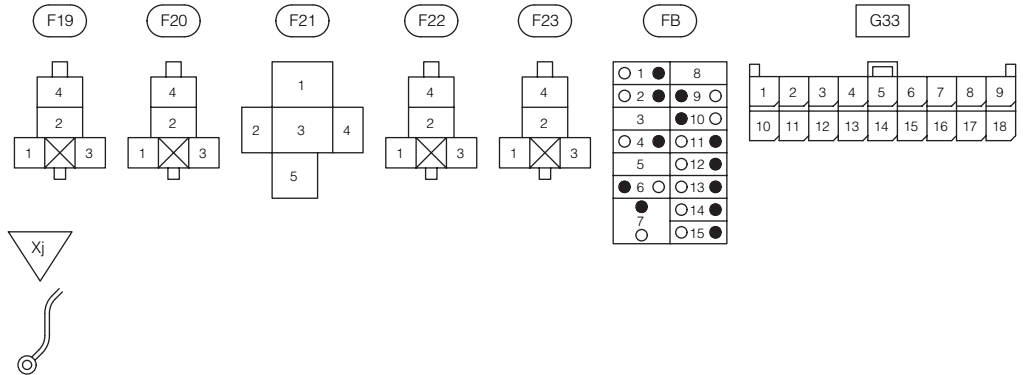
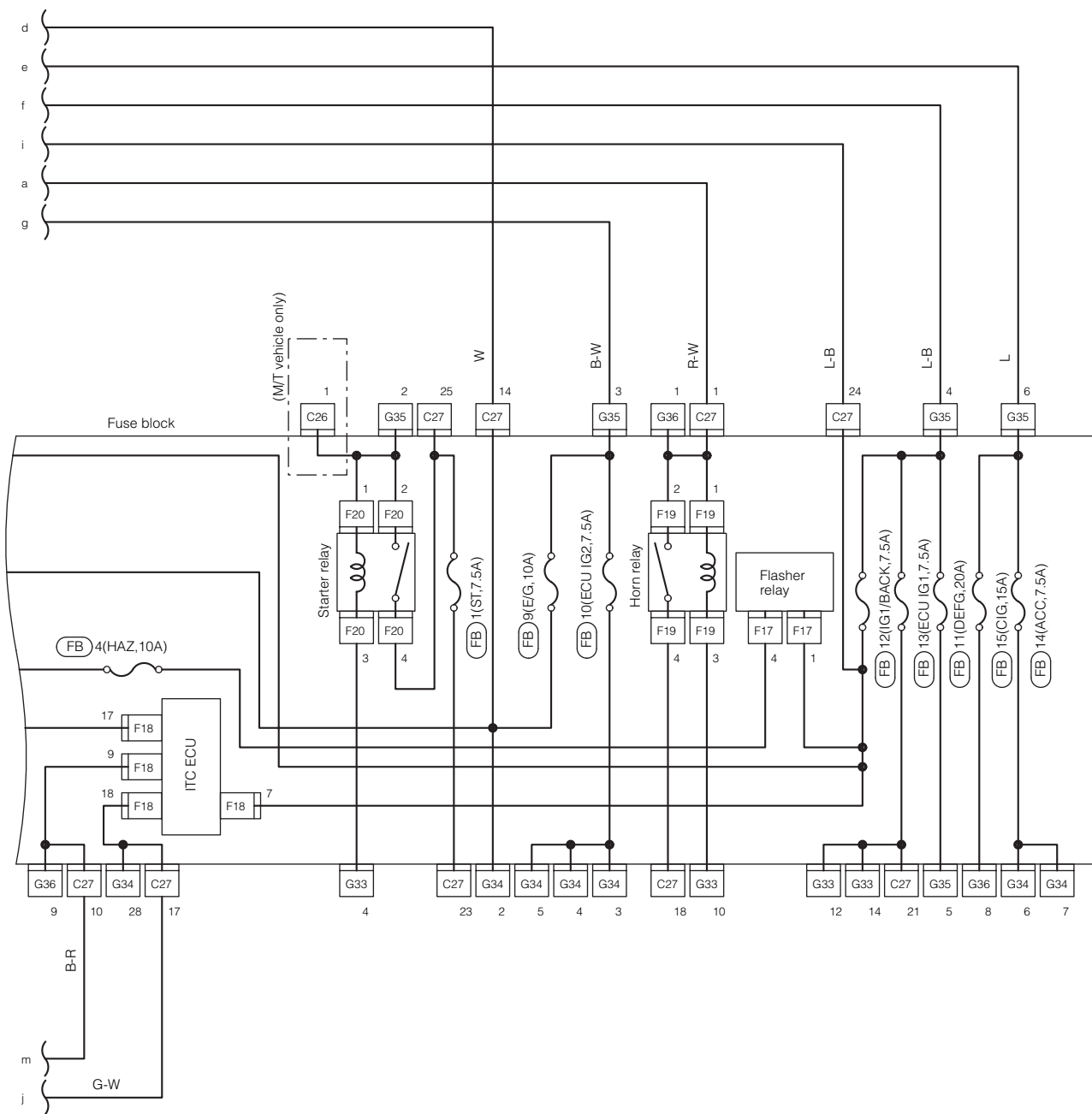

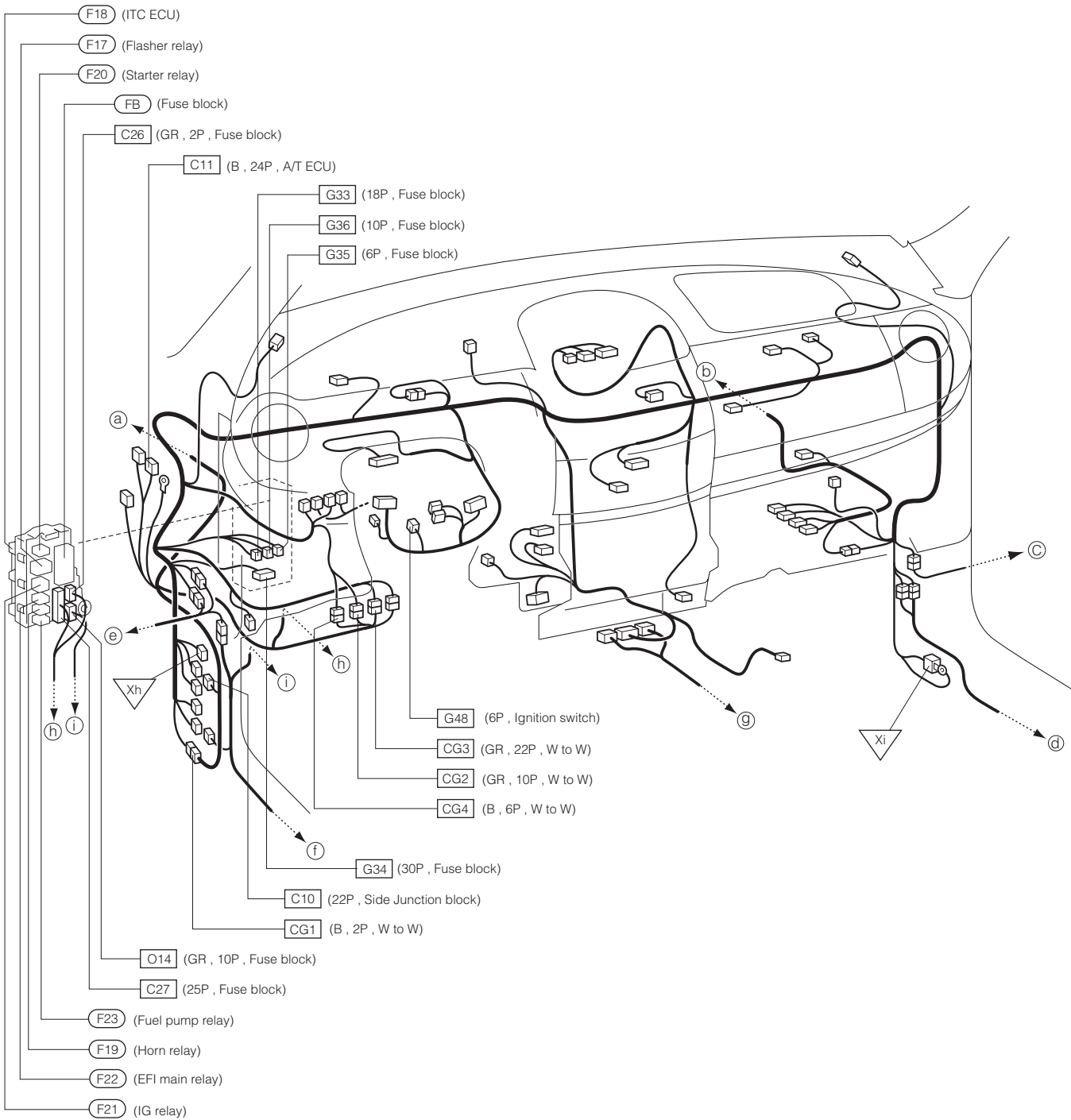

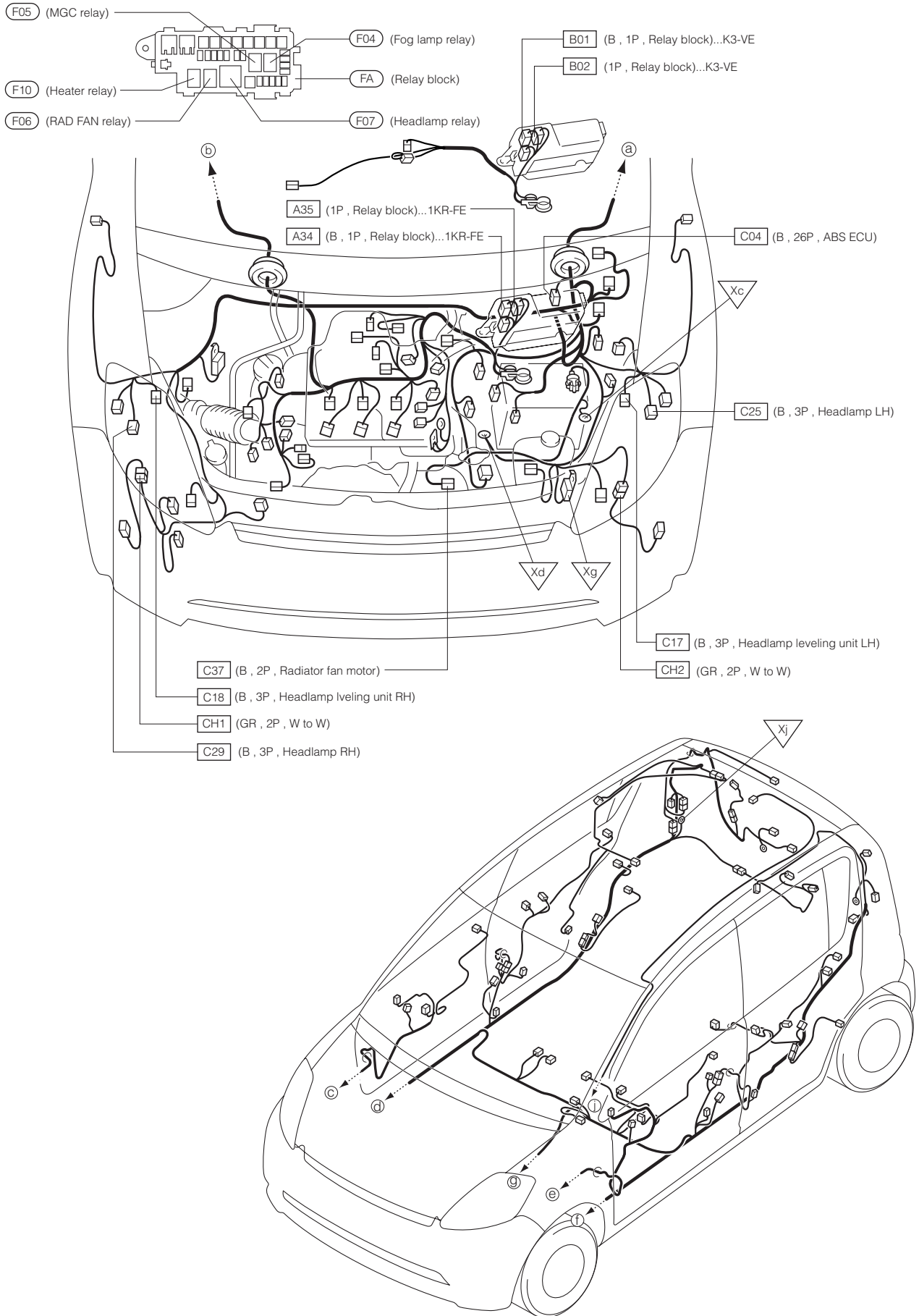

2 STARTING SYSTEM 2-1 RHD VEHICLE

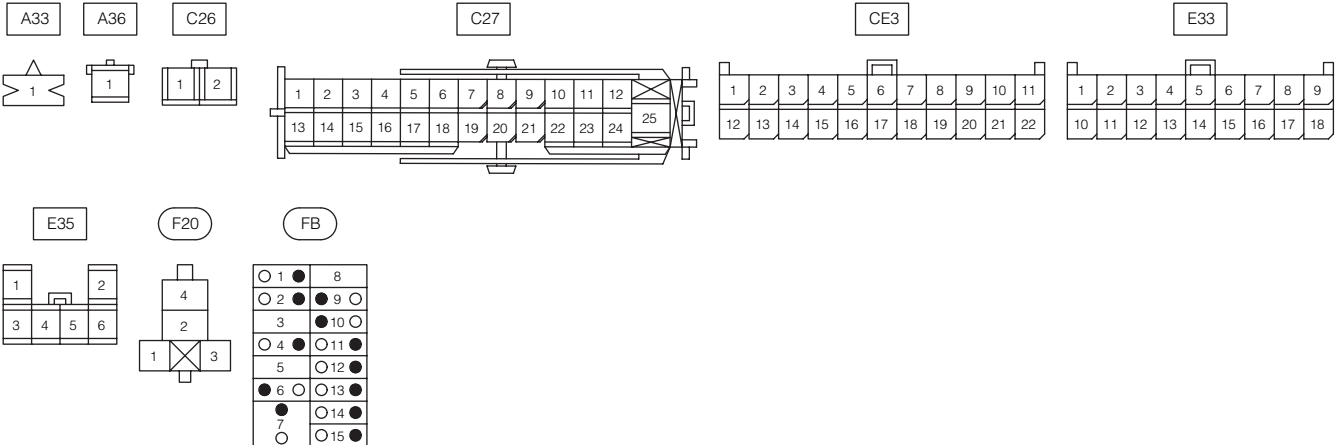
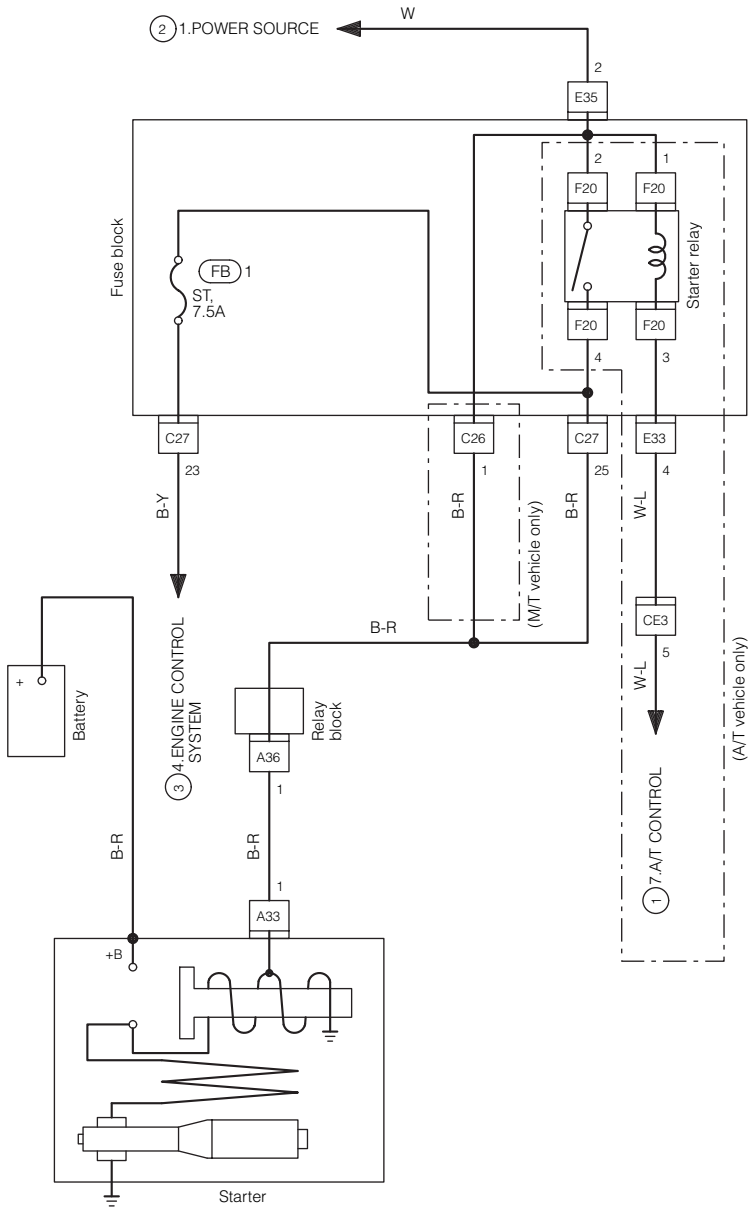

(MEMO)

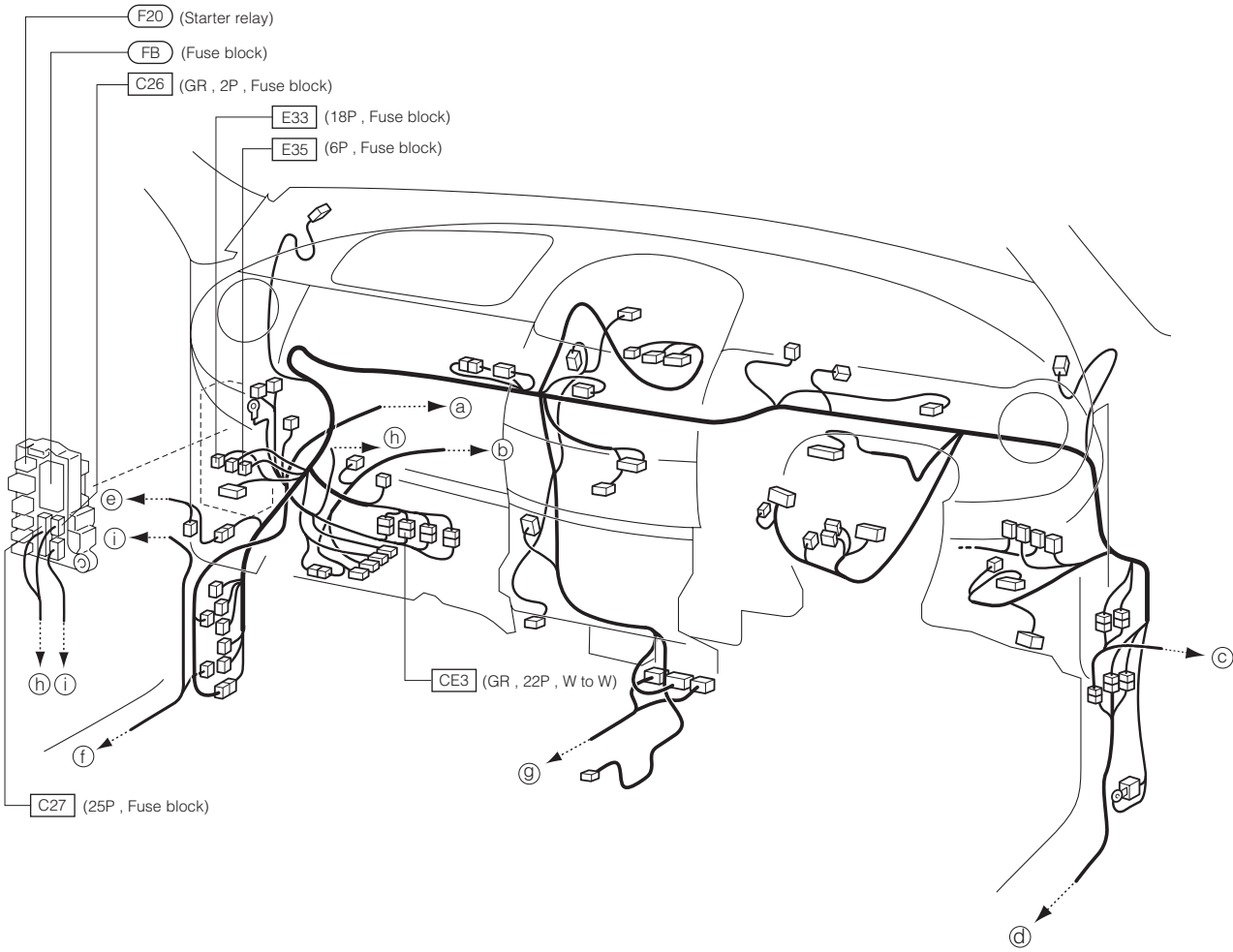

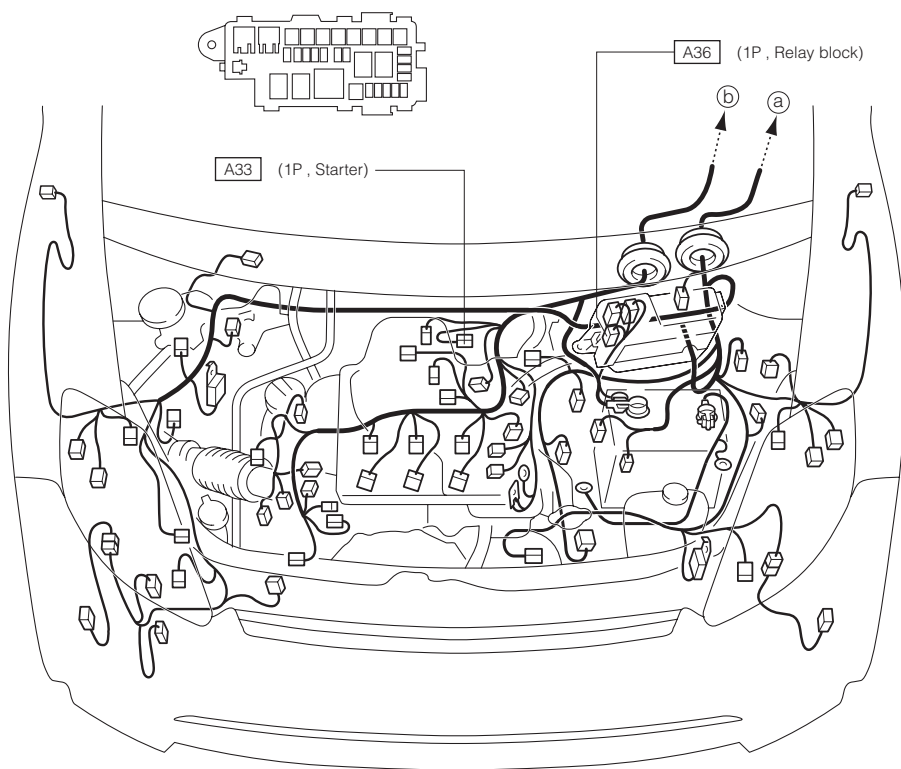

2-2 LHD VEHICLE

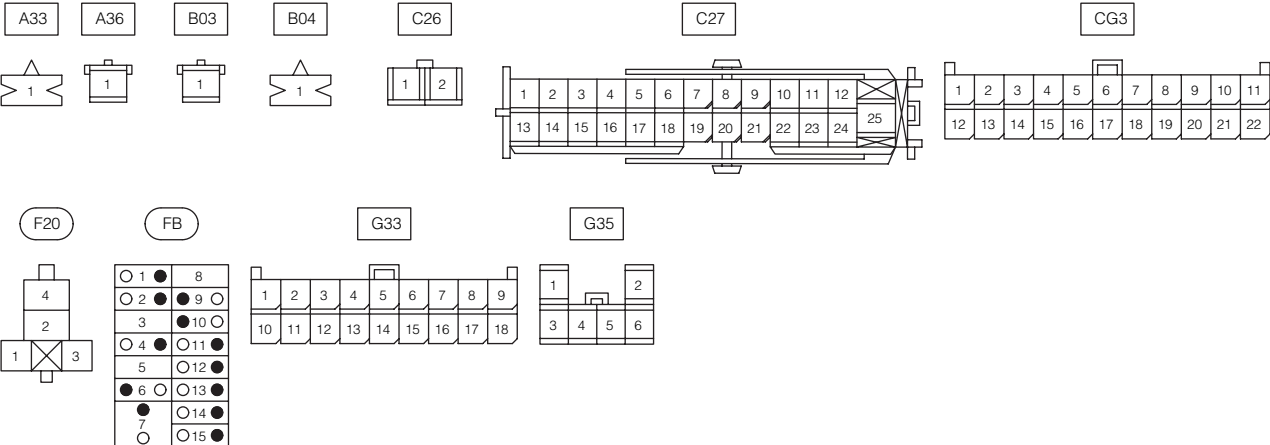
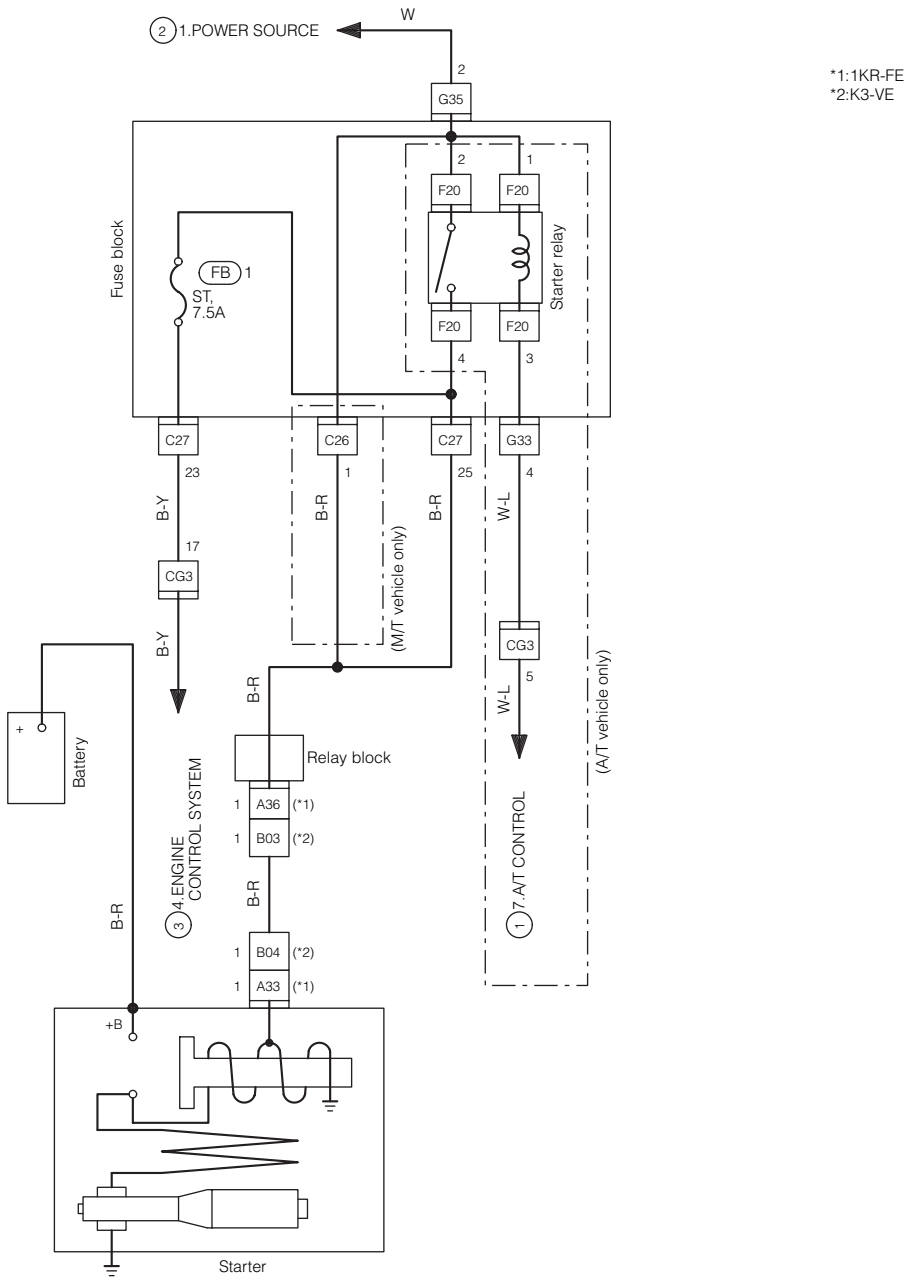

(MEMO)

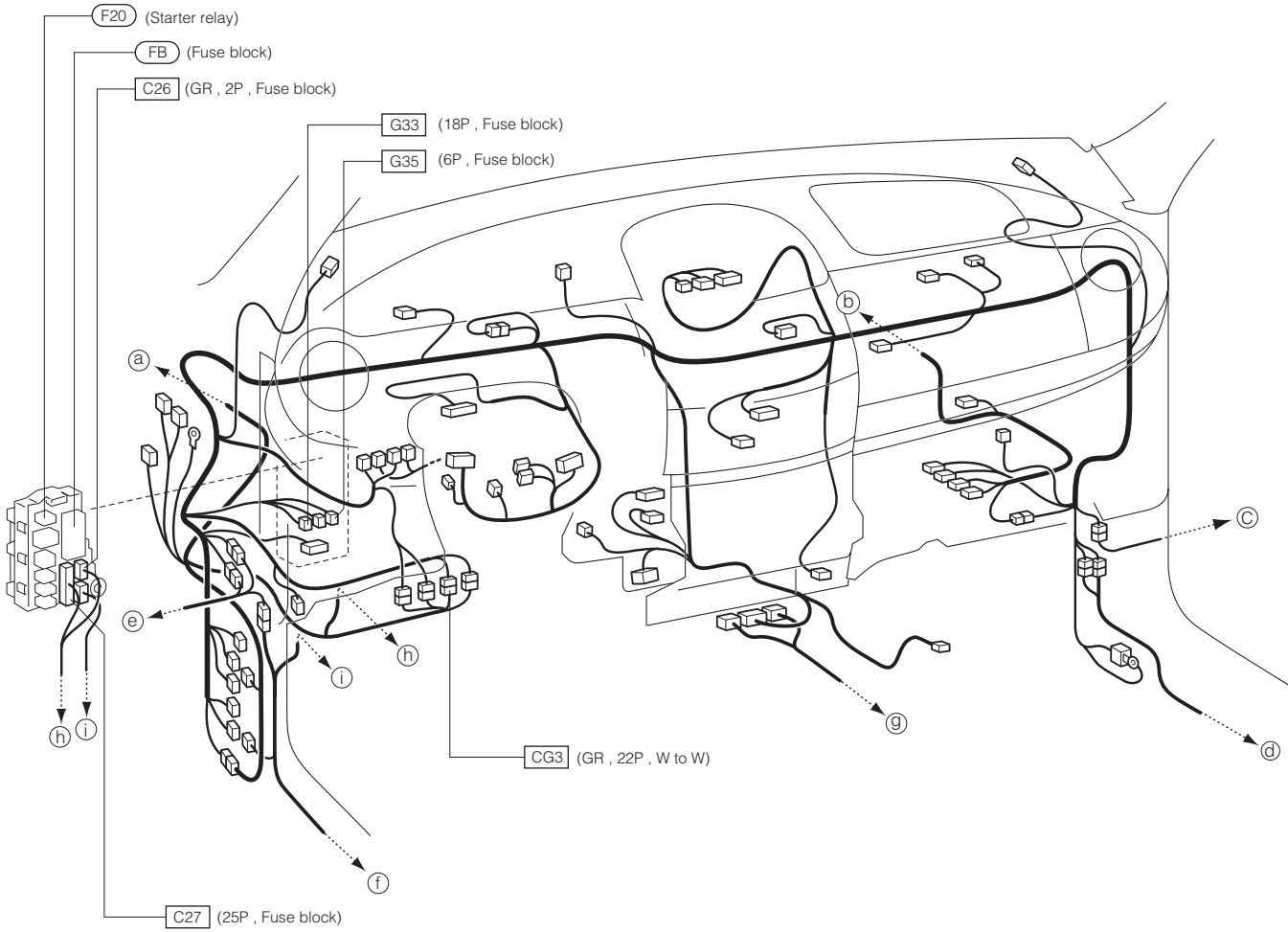

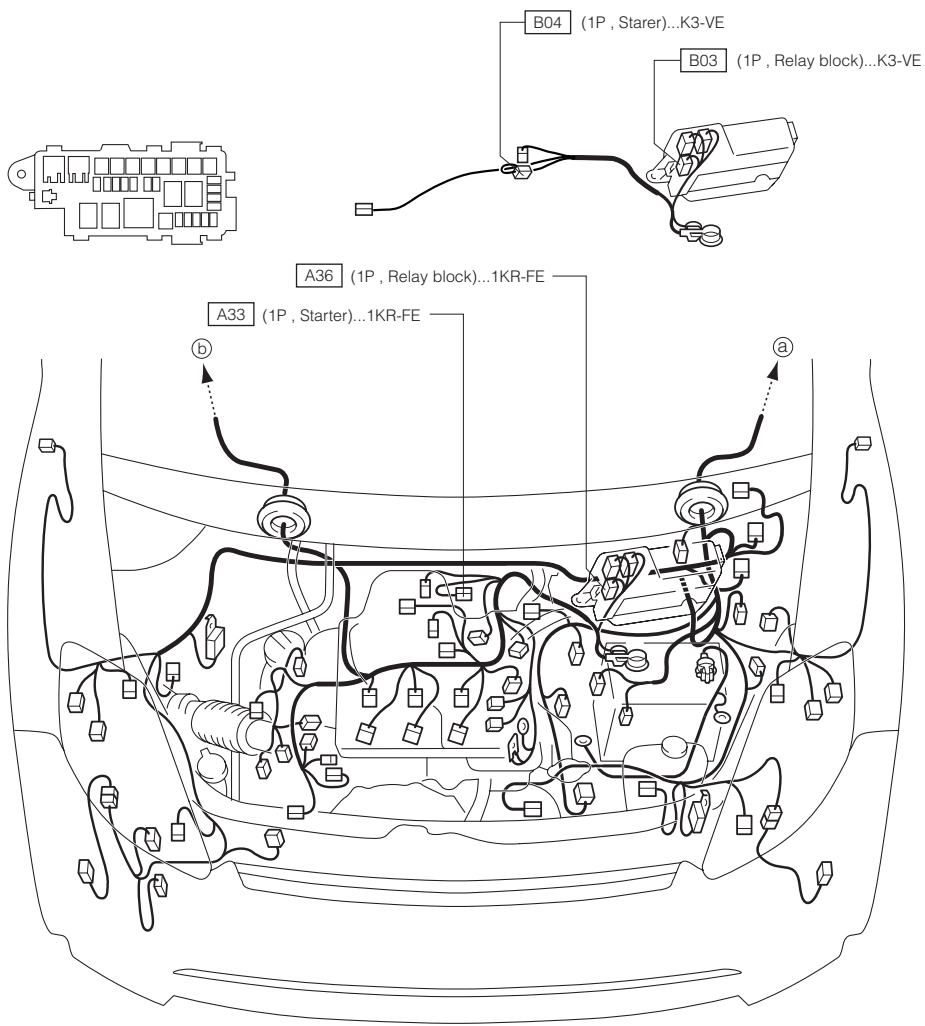

3 CHARGING SYSTEM 3-1 RHD VEHICLE

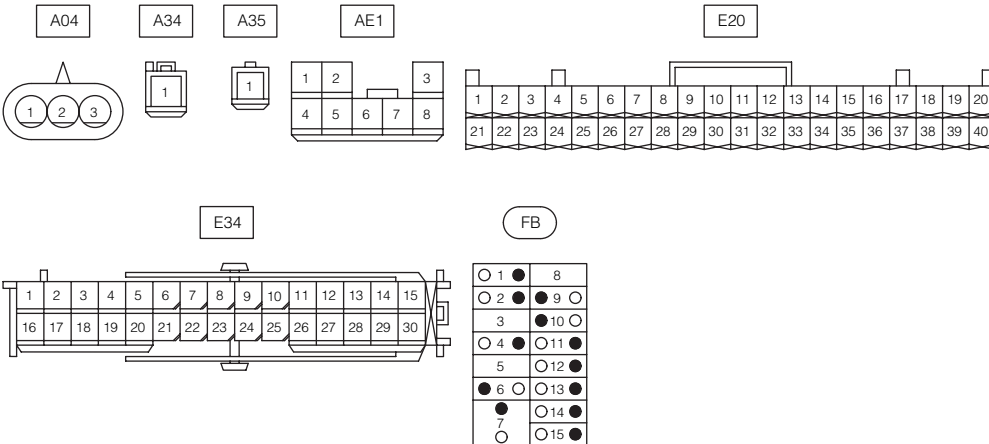
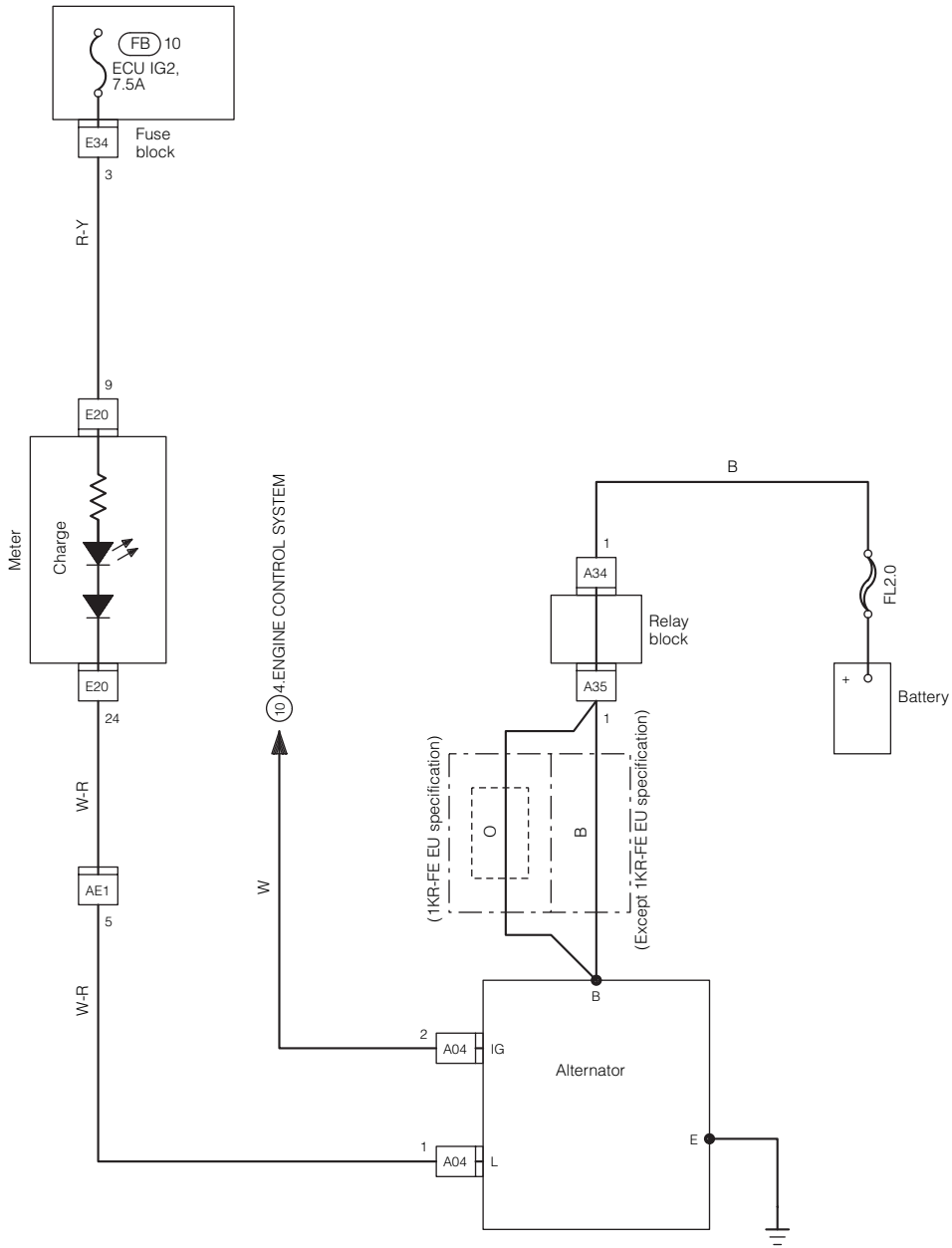

(MEMO)

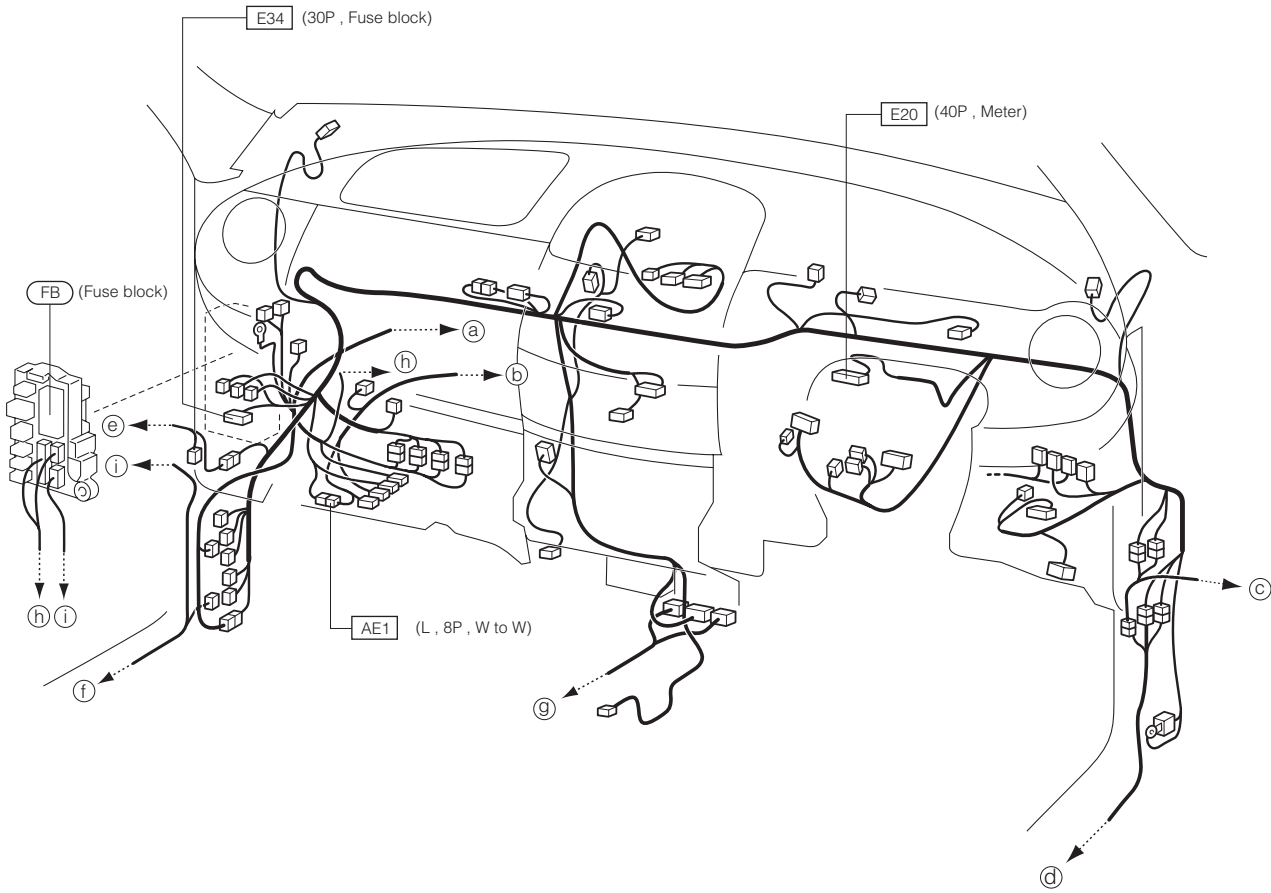

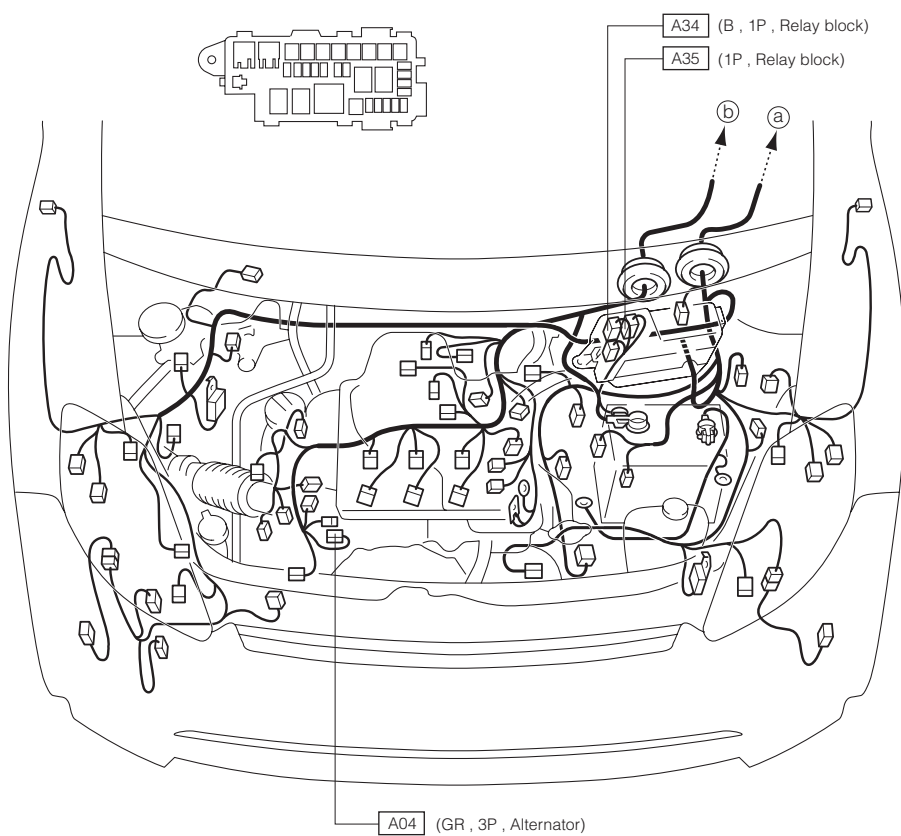

3-2 LHD VEHICLE

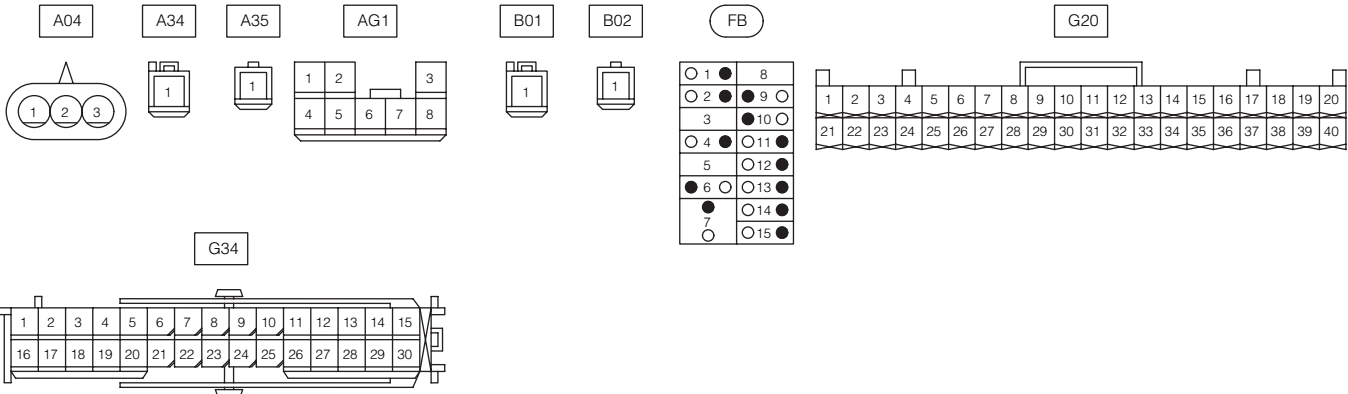
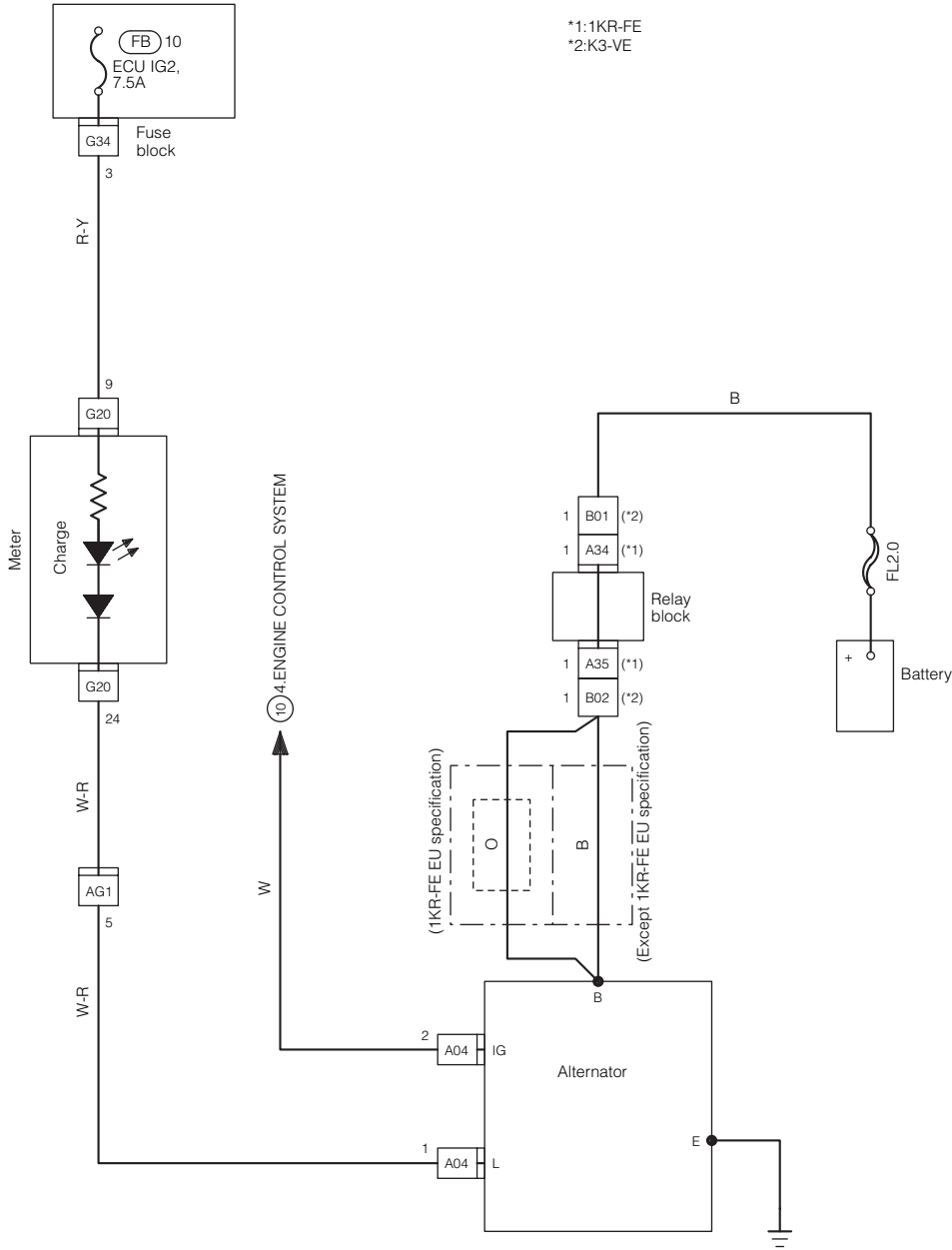

(MEMO)

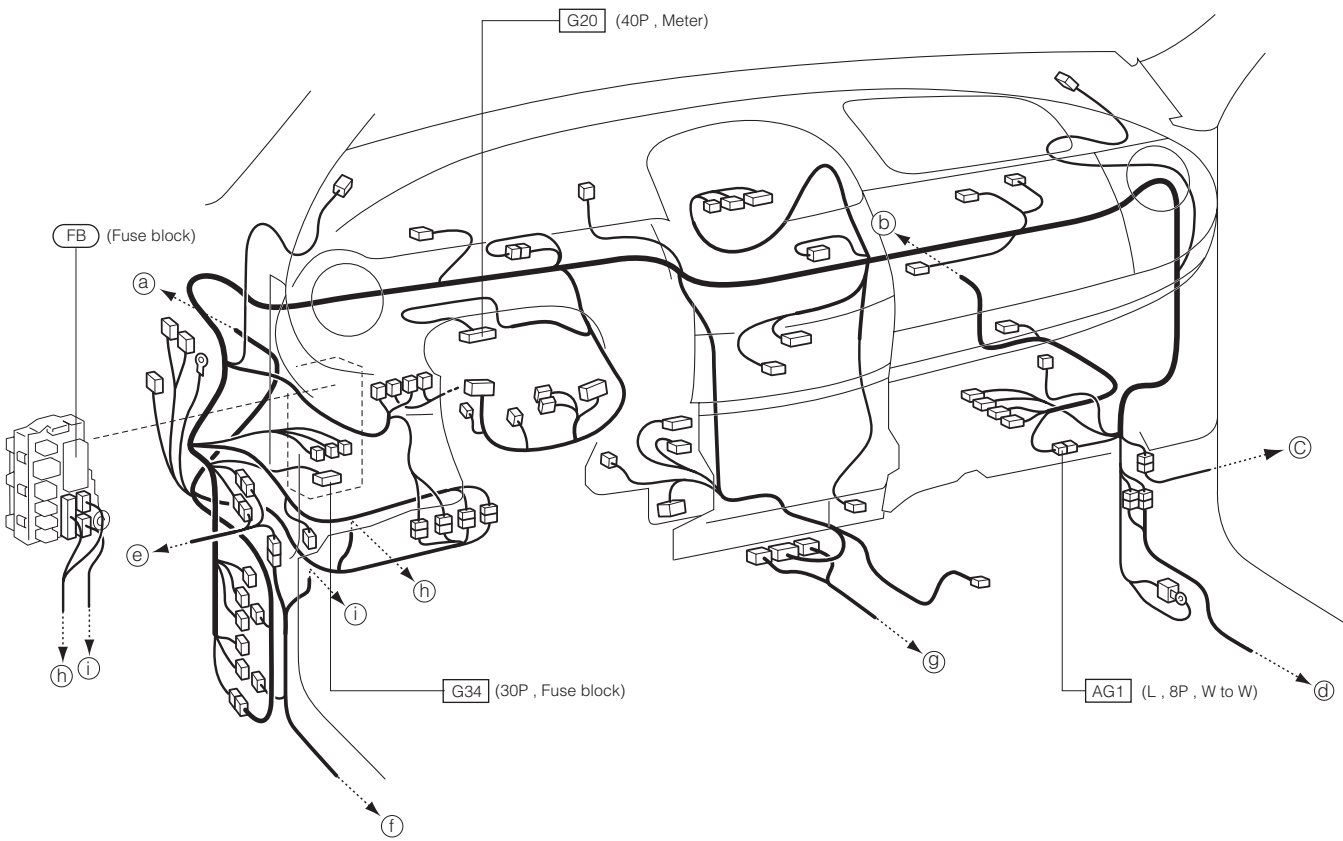

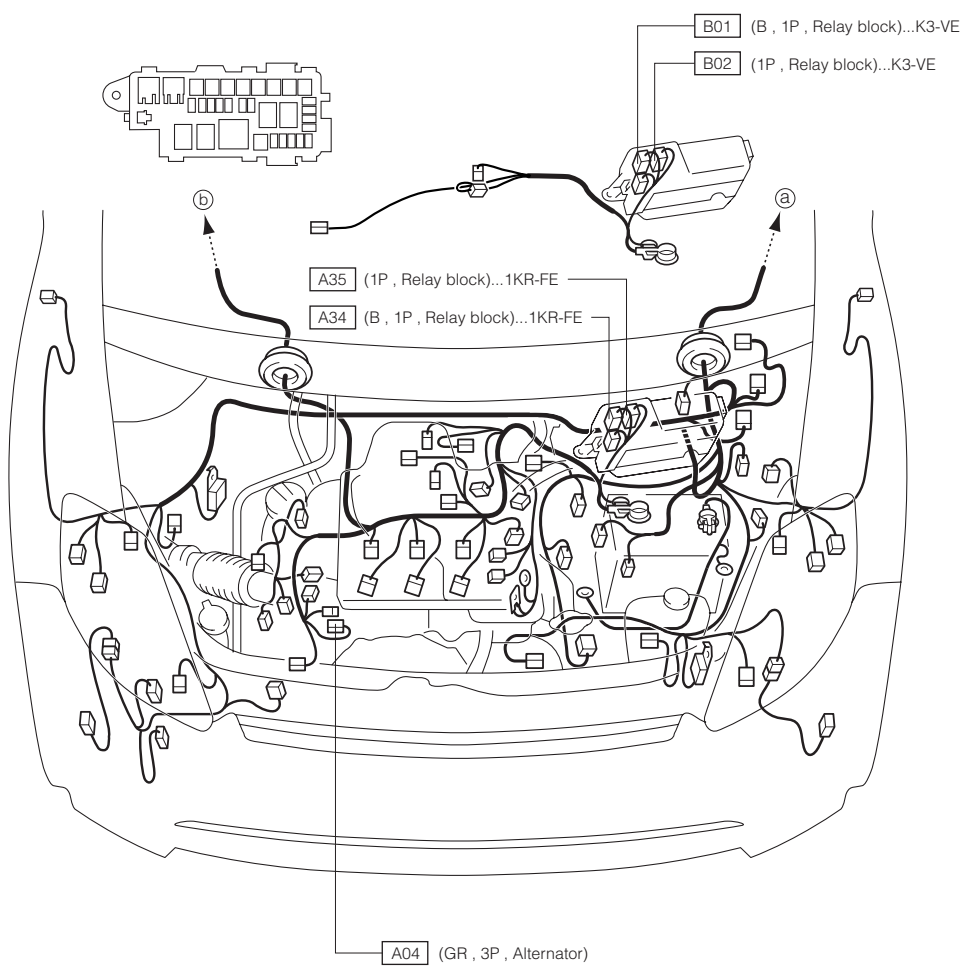

4 ENGINE CONTROL SYSTEM 4-1 RHD VEHICLE(1KR-FE ENGINE)

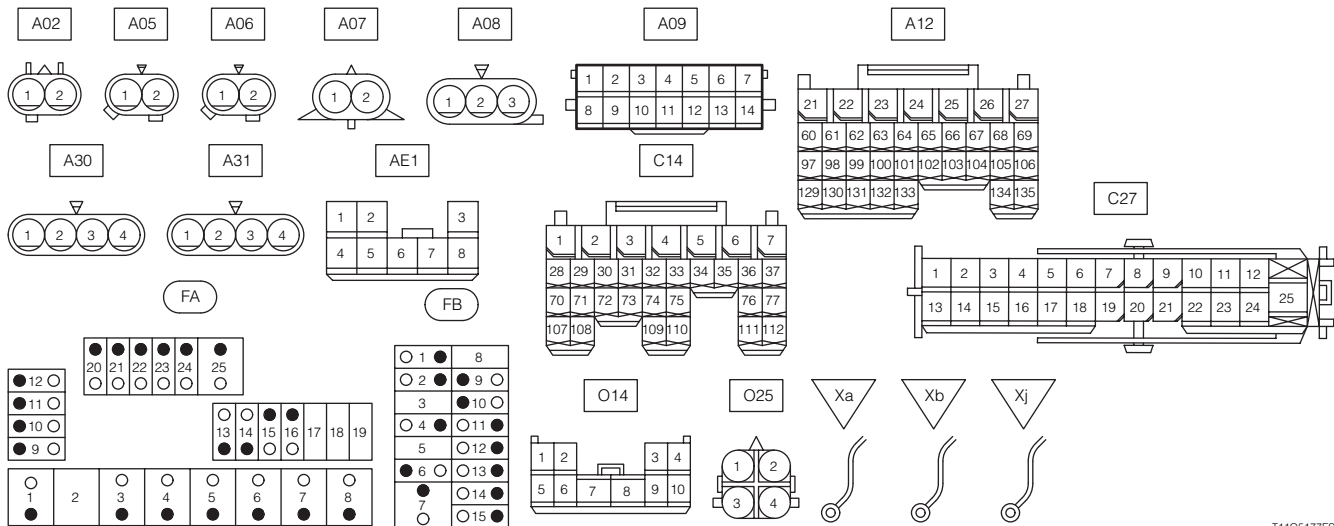
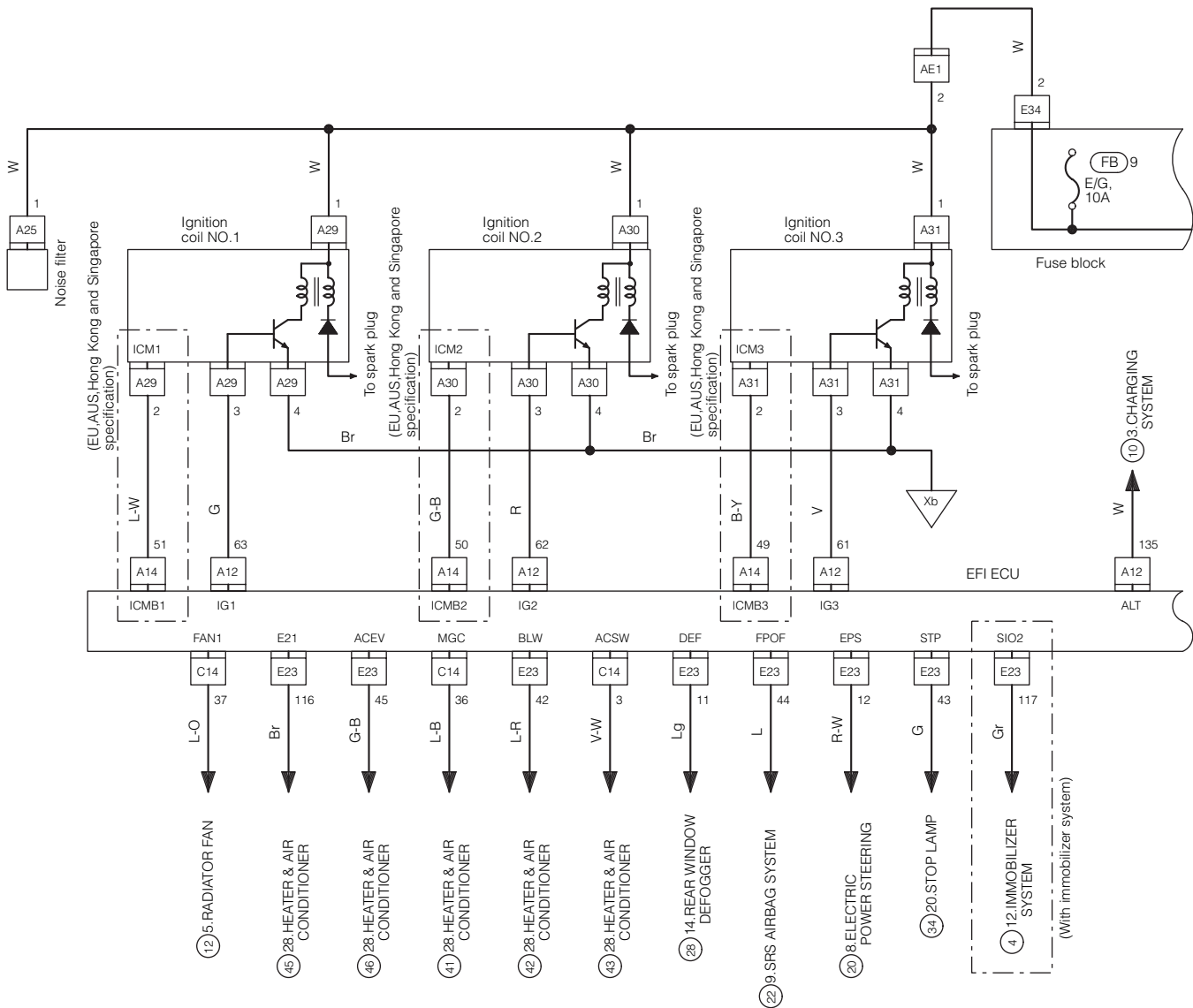

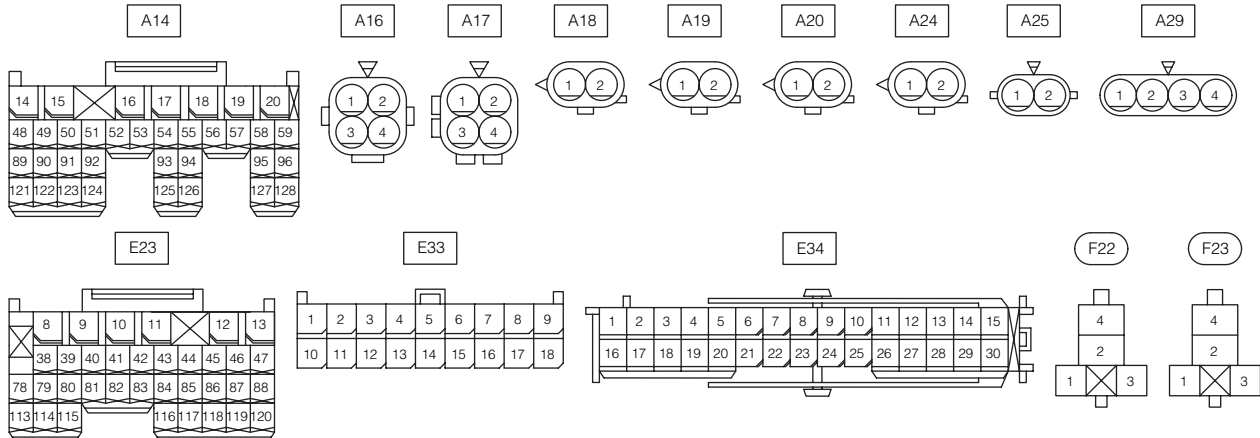
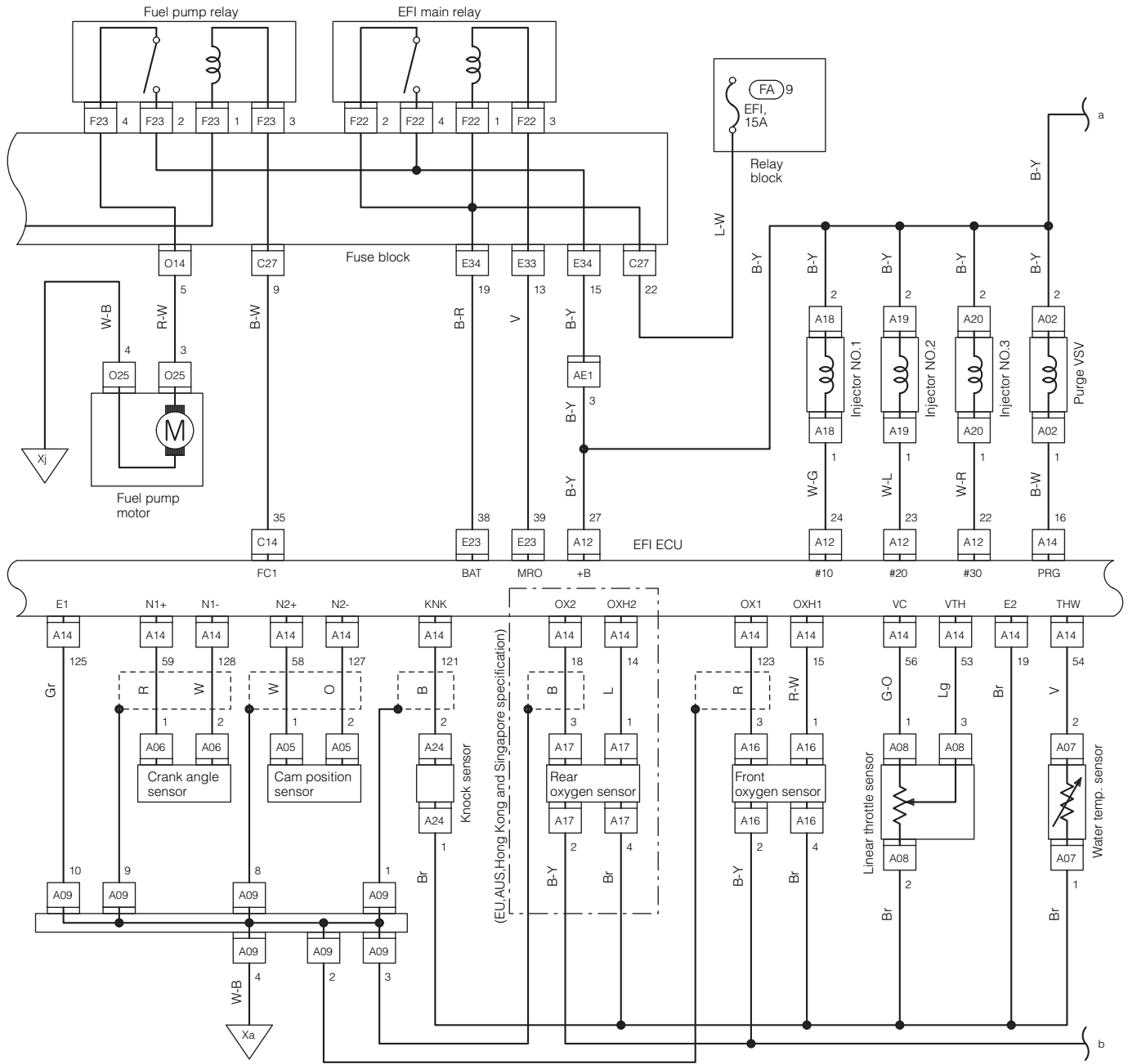

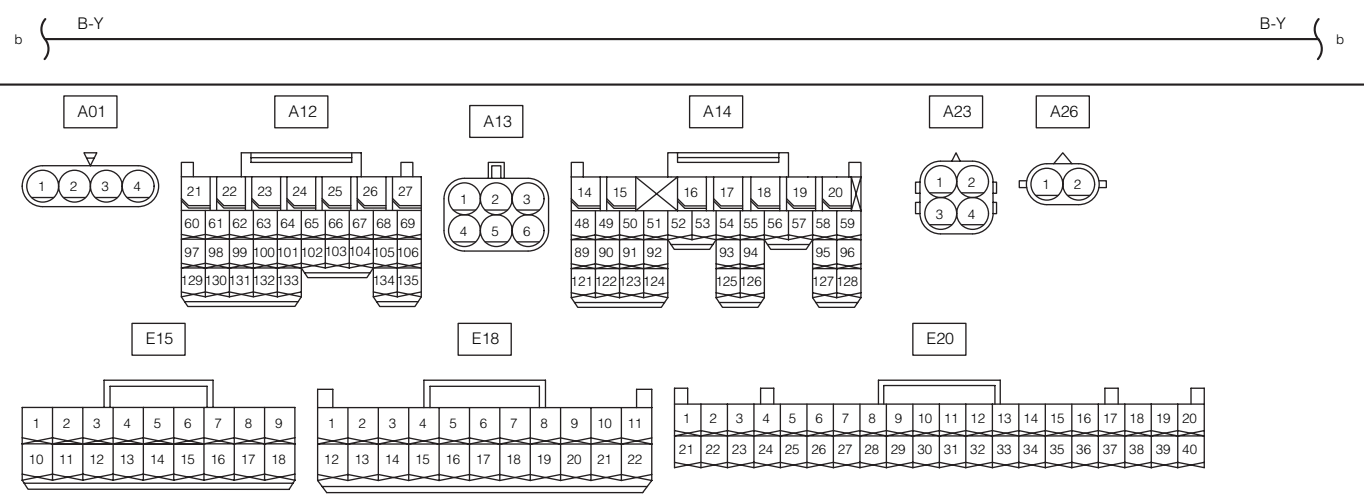
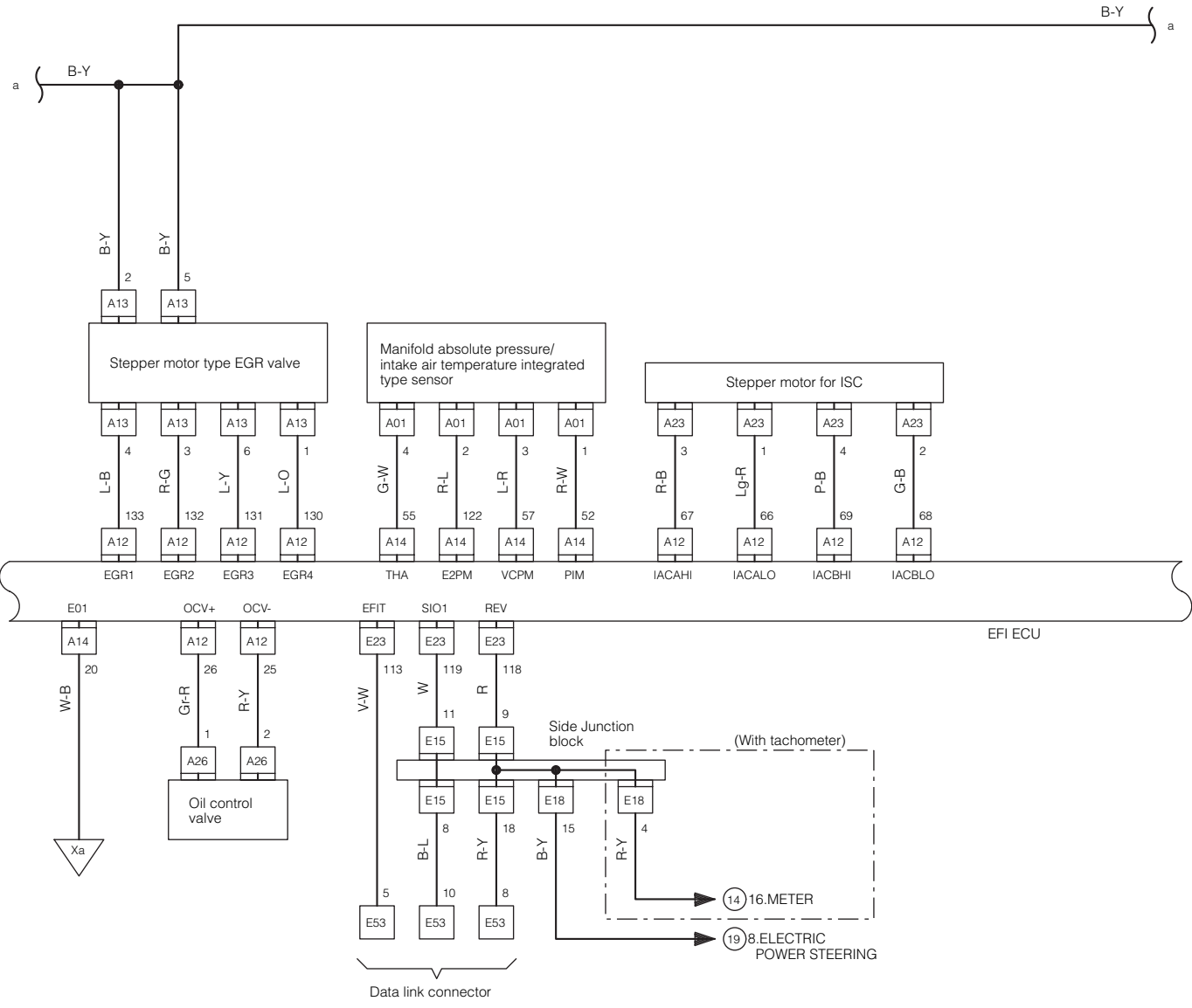

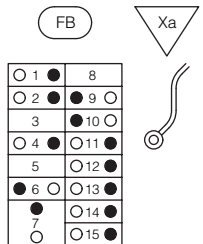
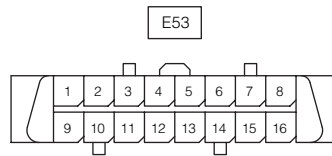
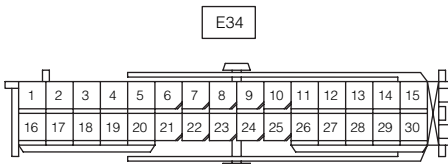
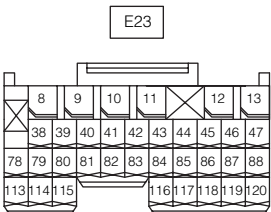
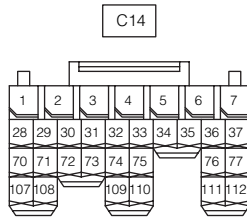
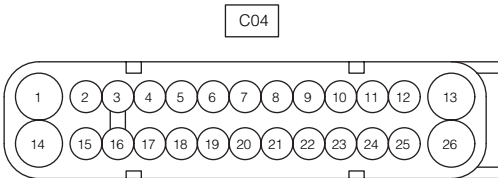
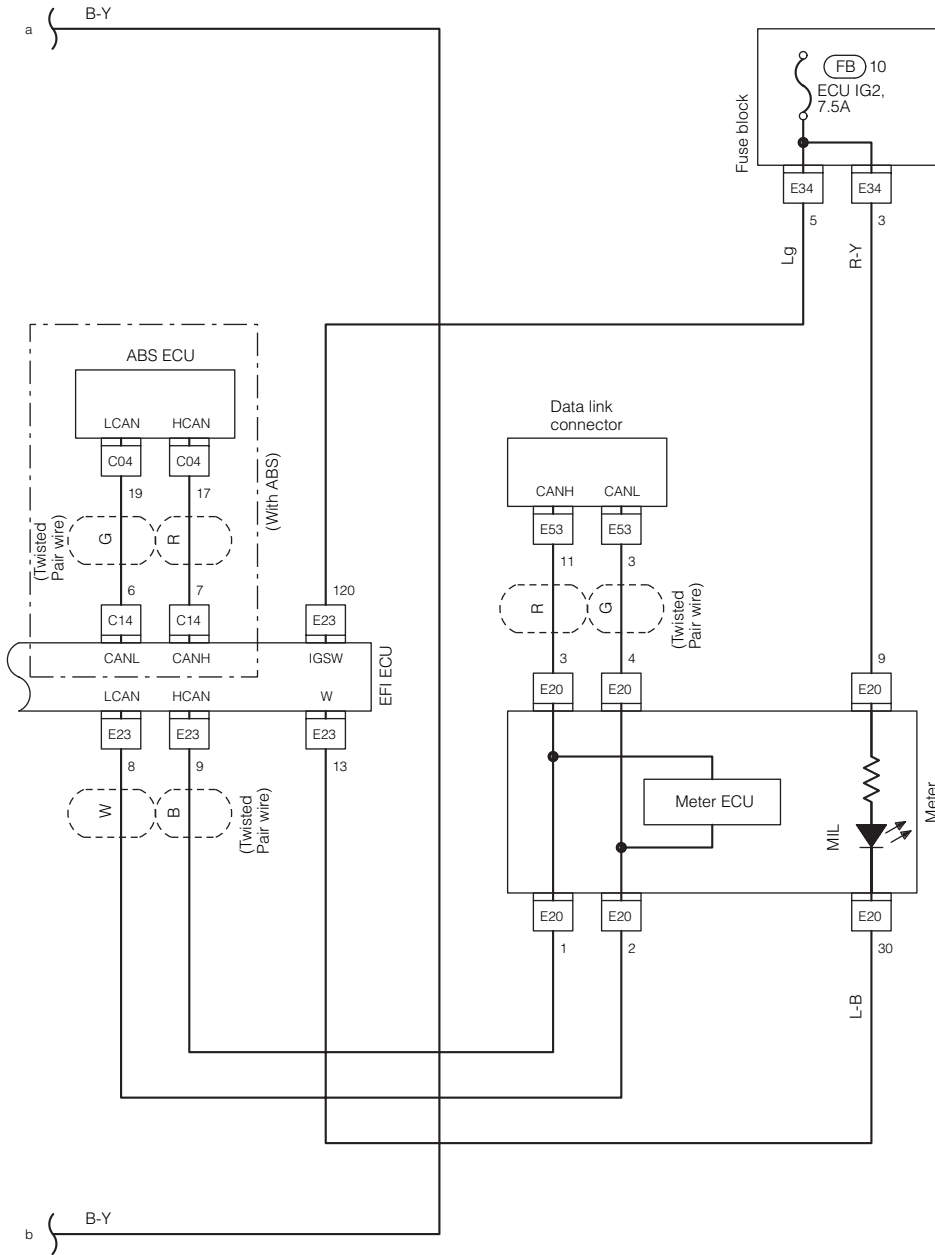

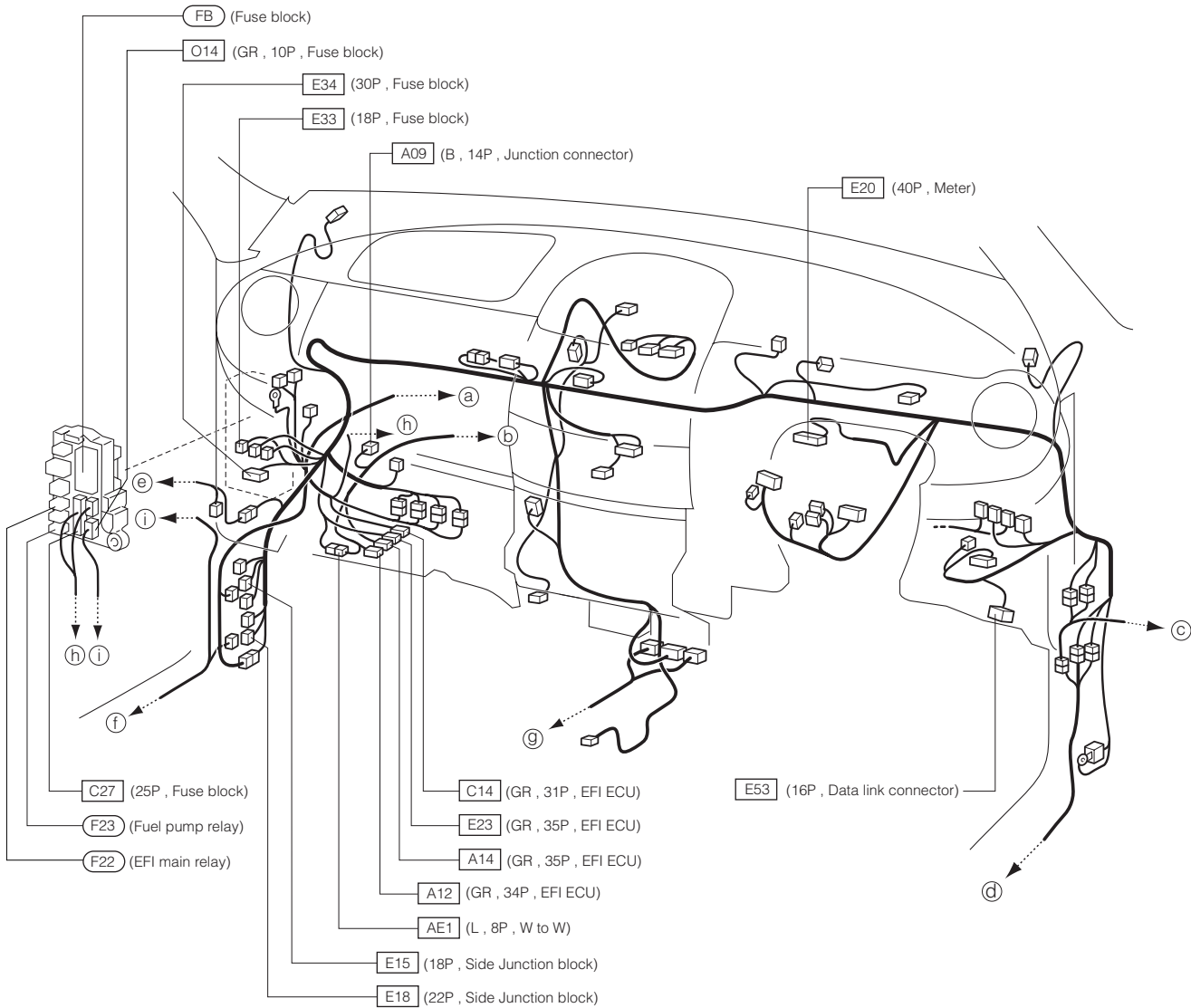

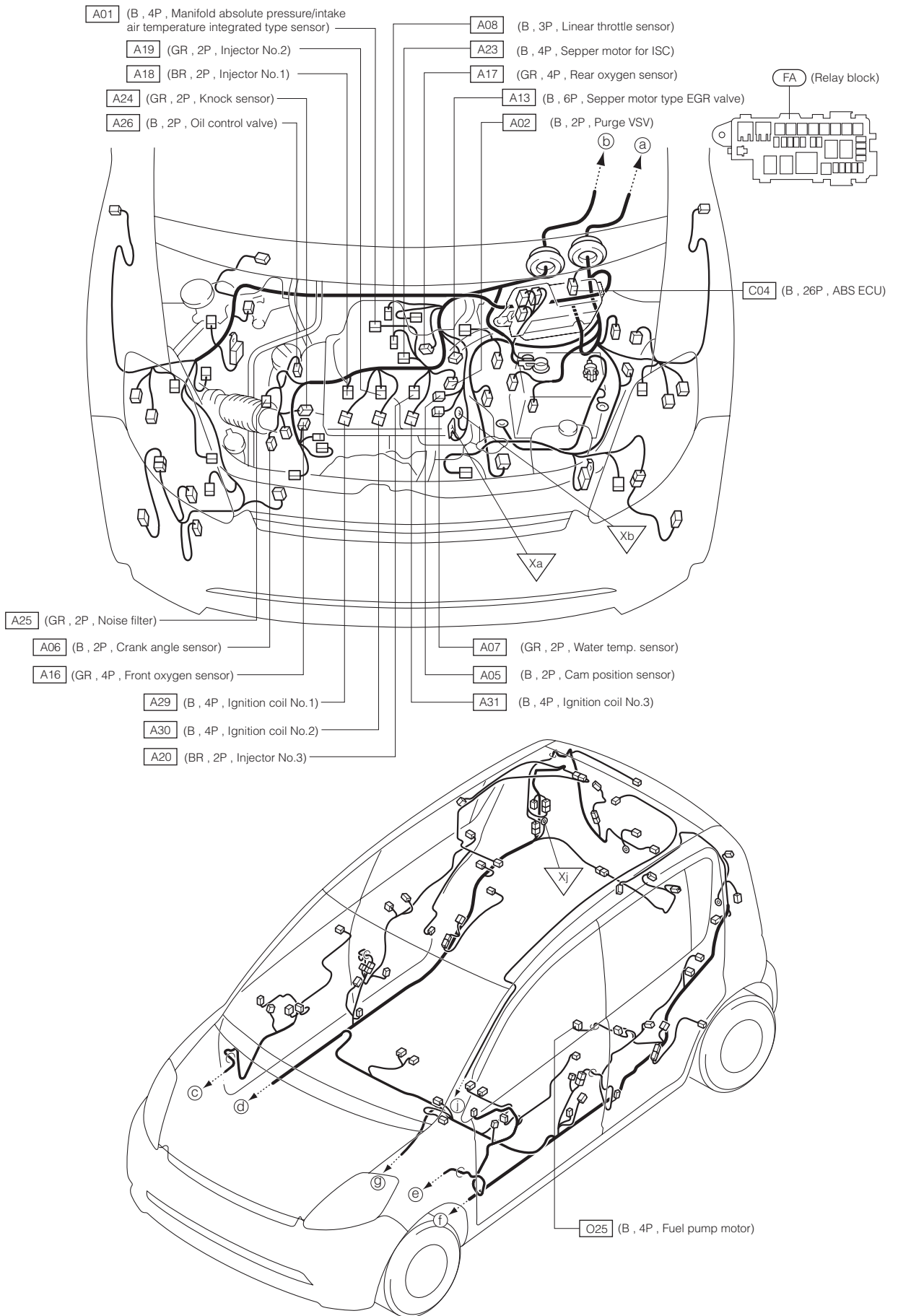

4-2 LHD VEHICLE(1KR-FE ENGINE)

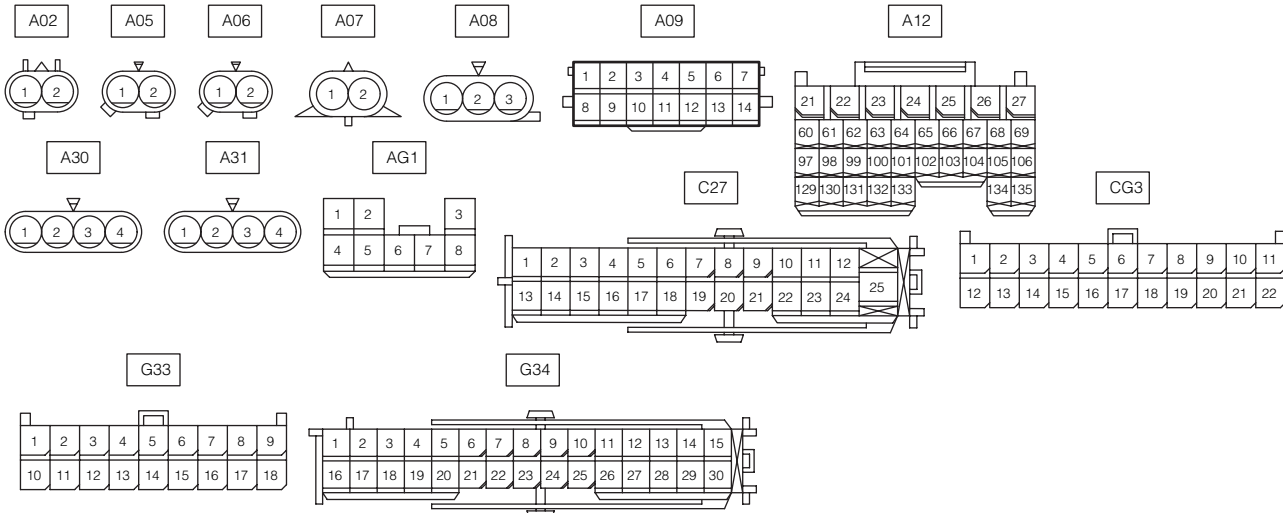
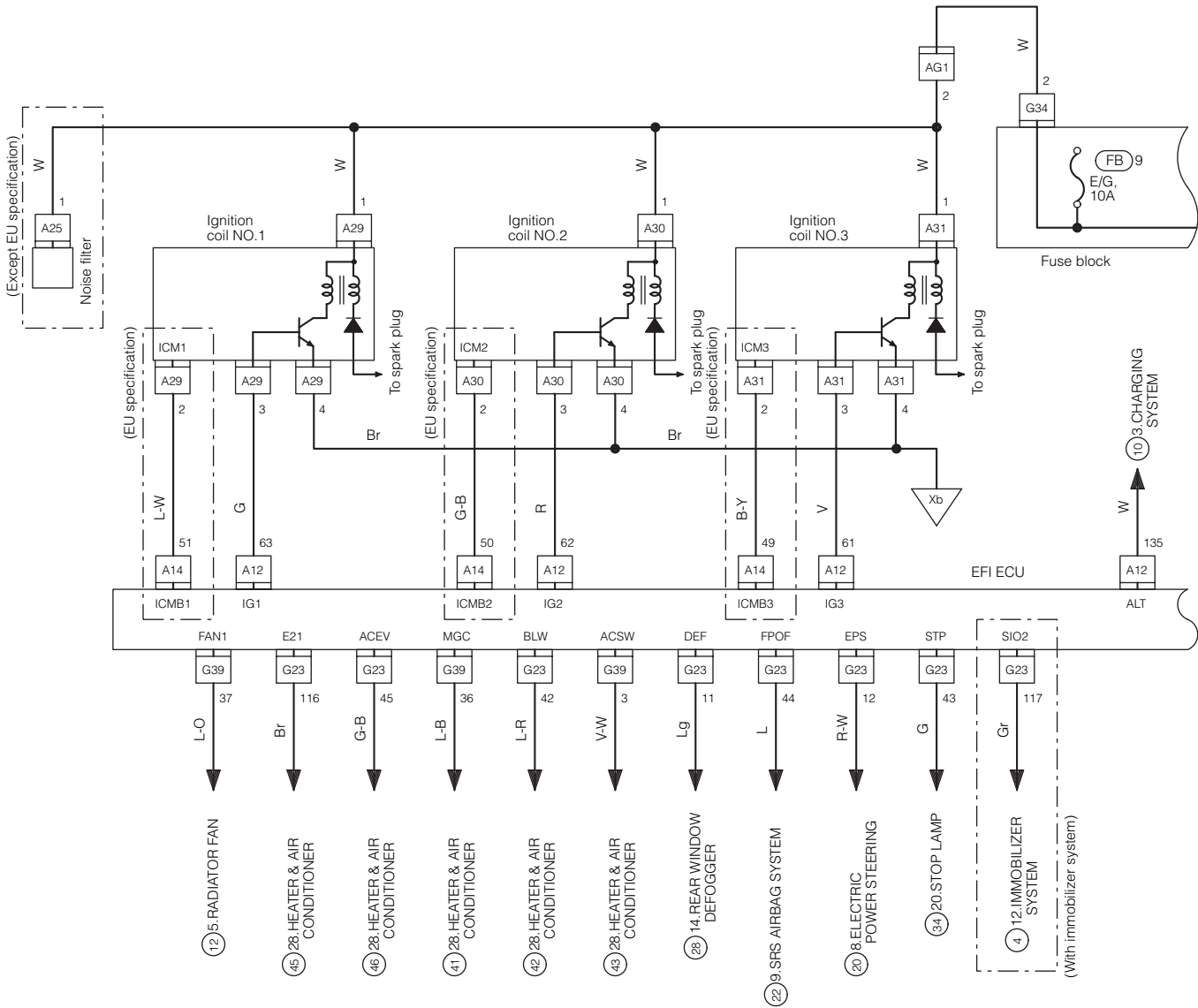

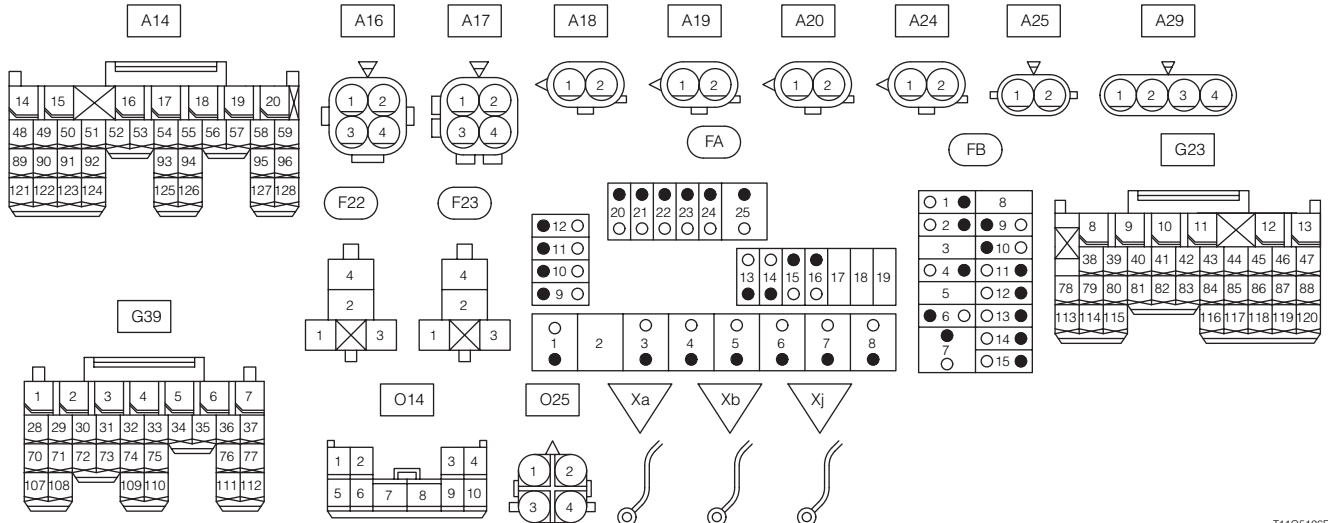
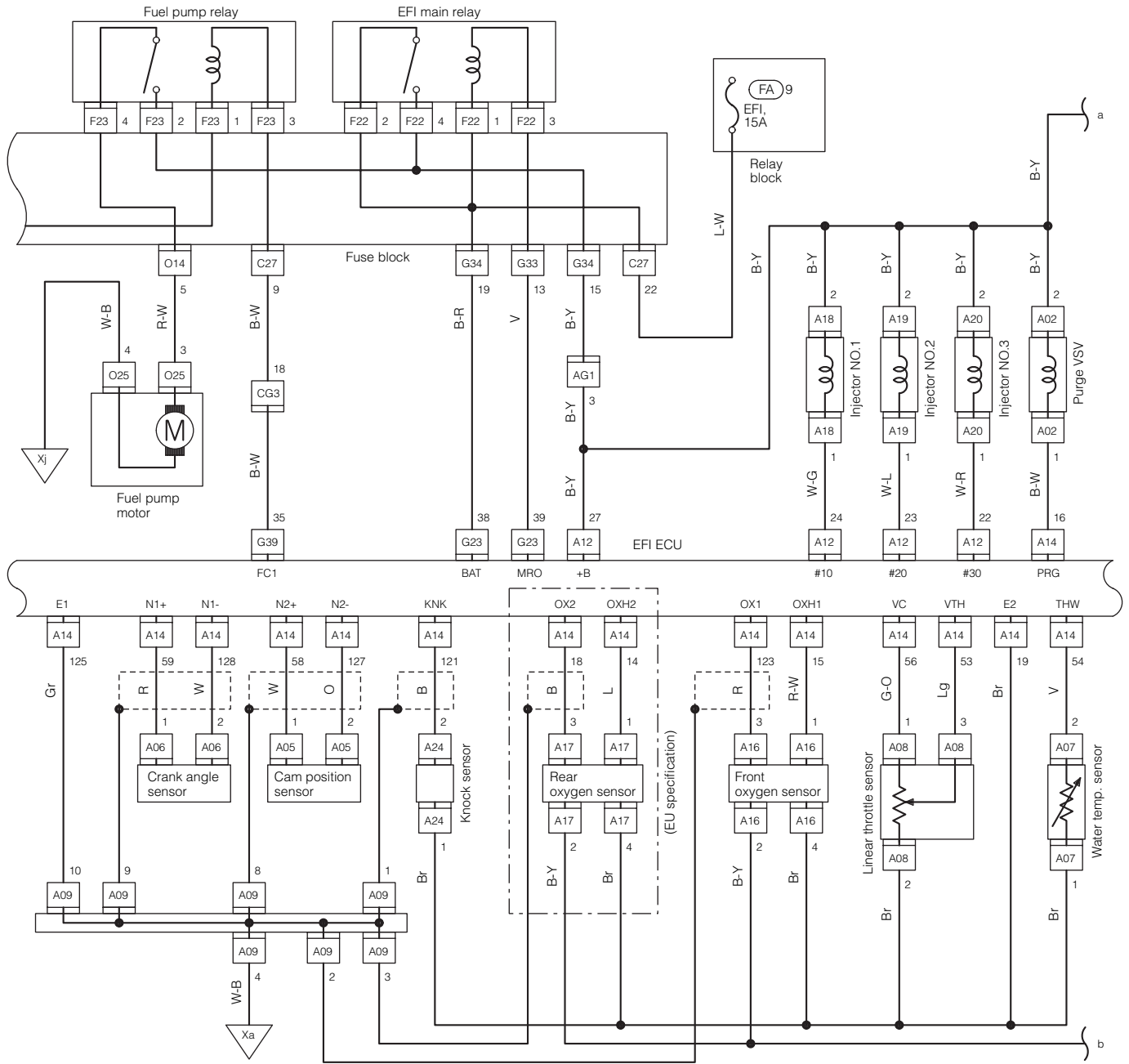

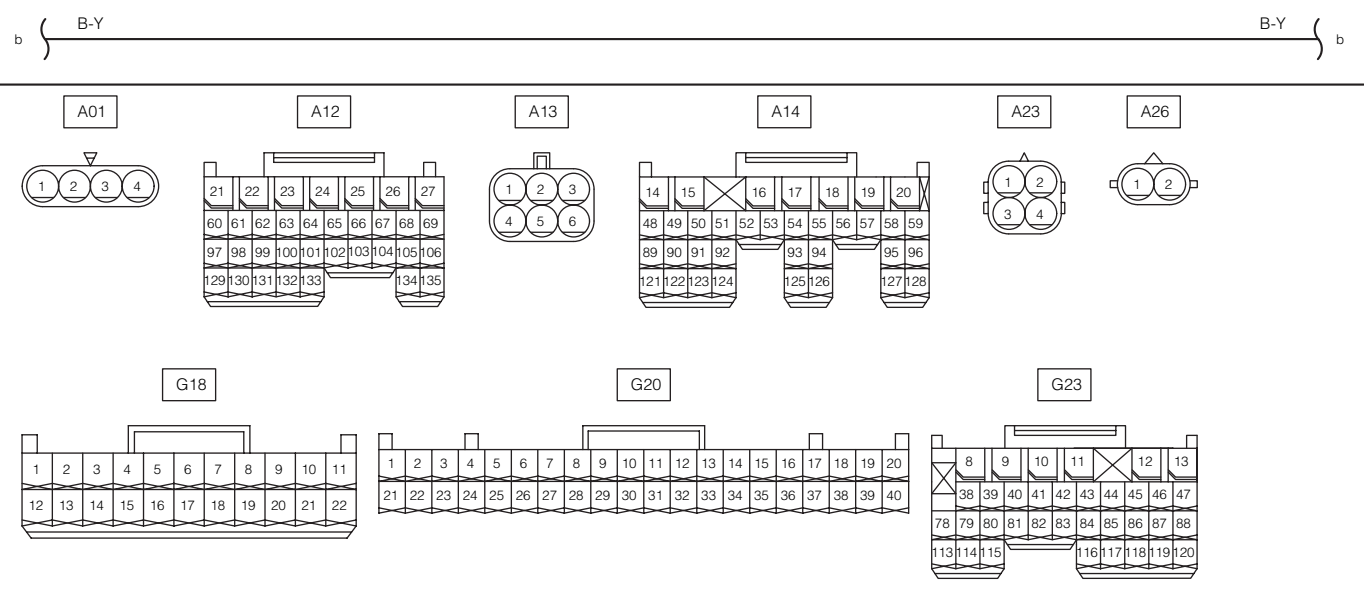
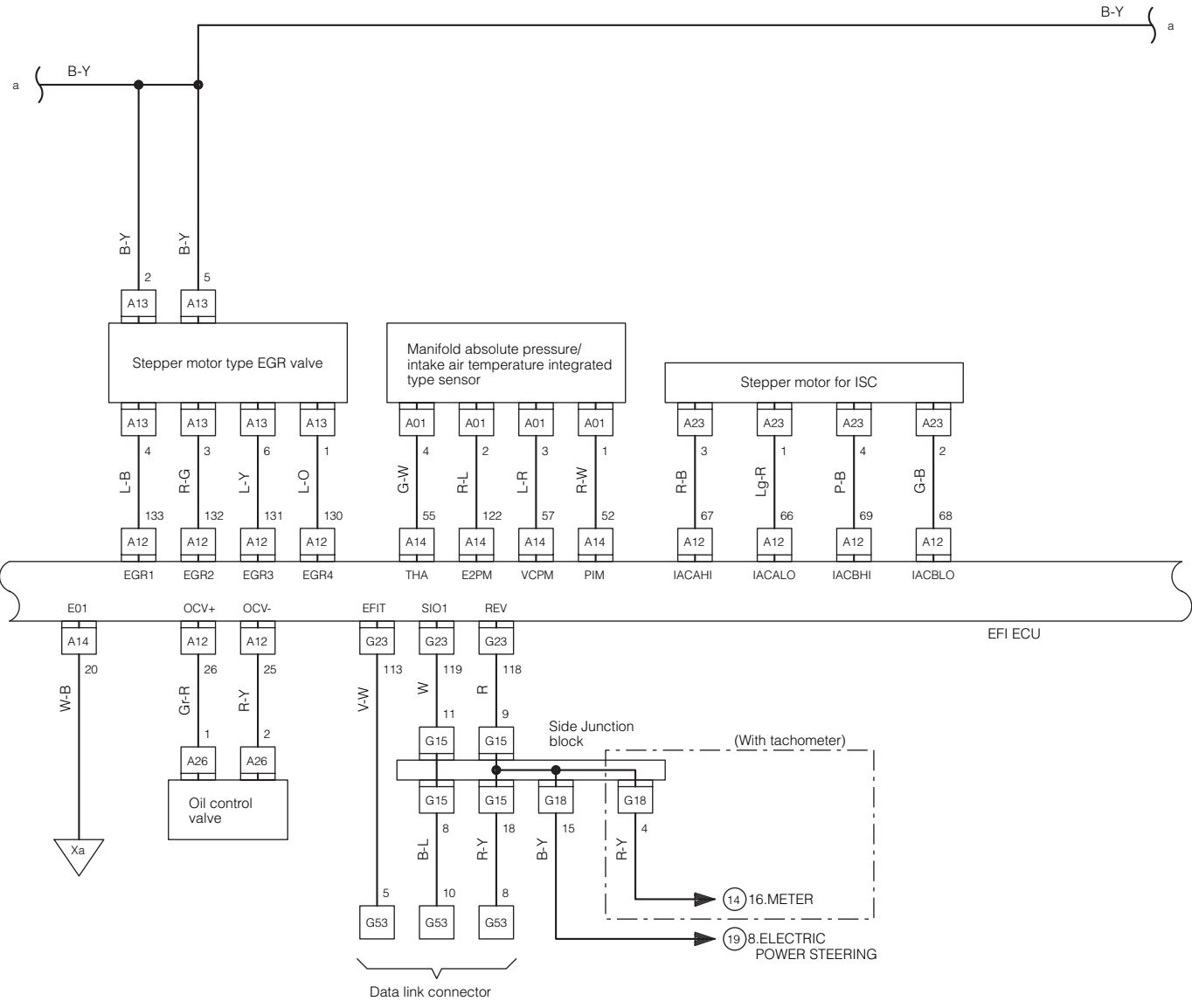

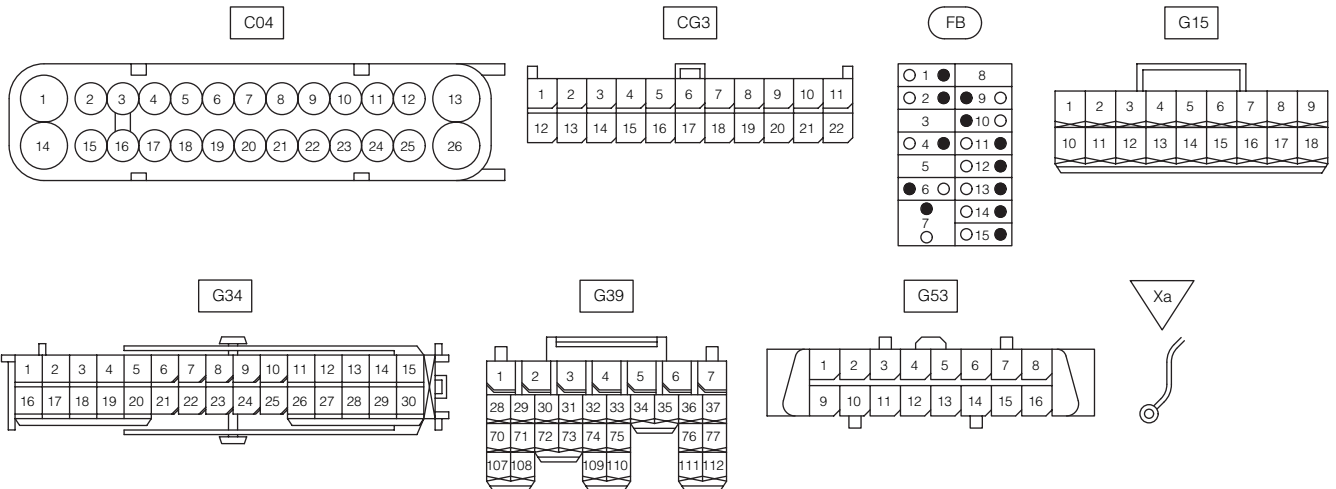
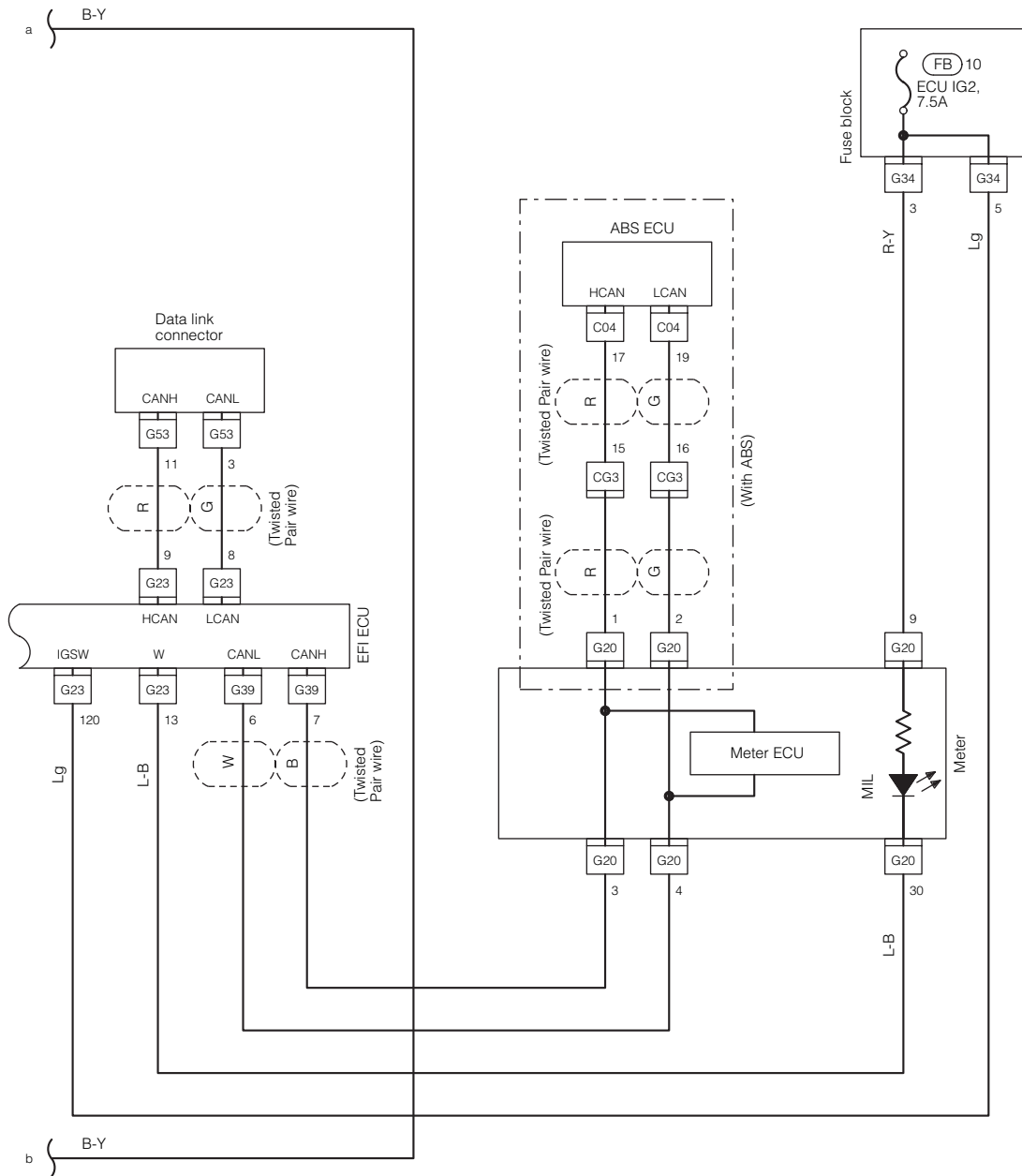

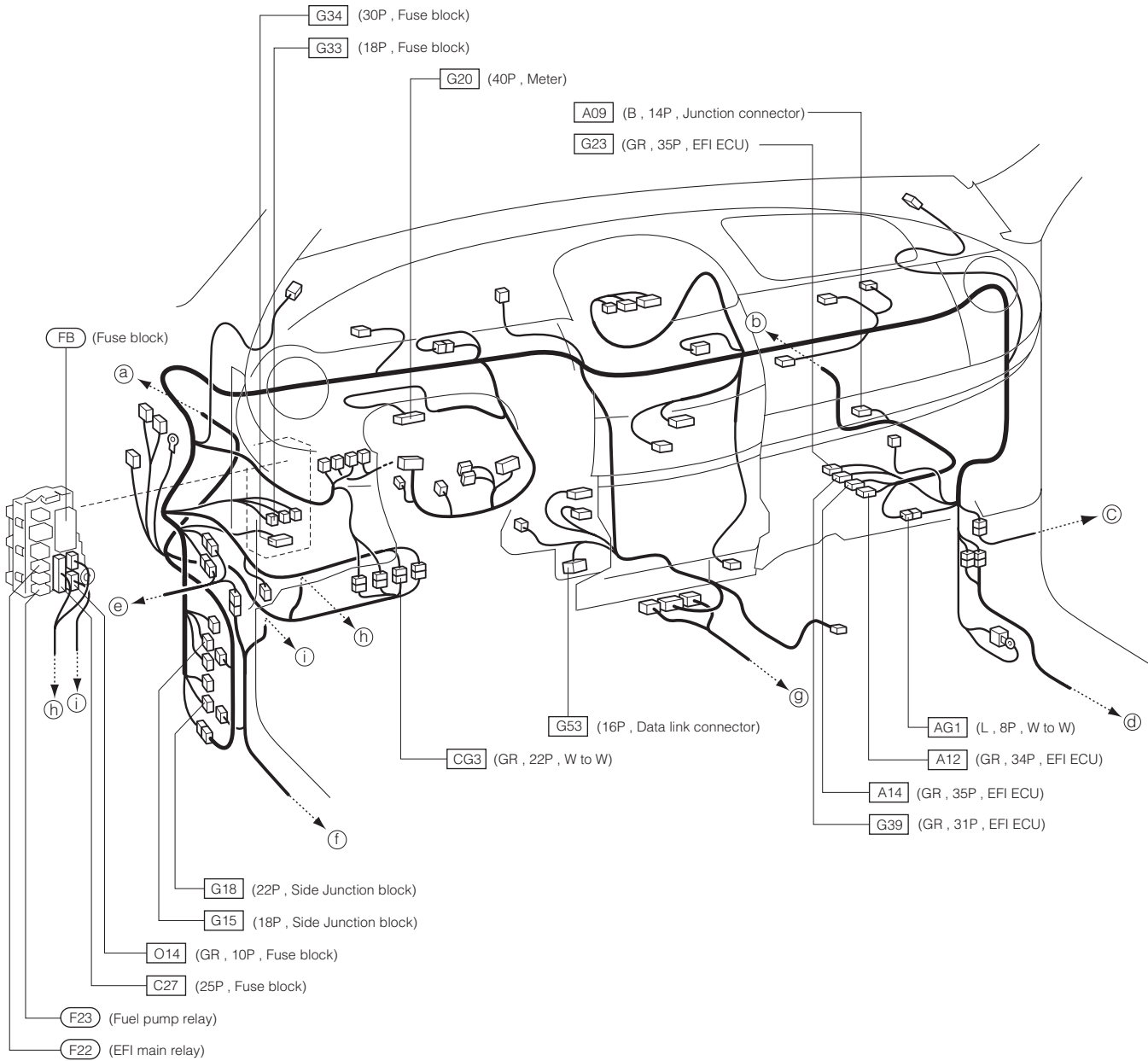

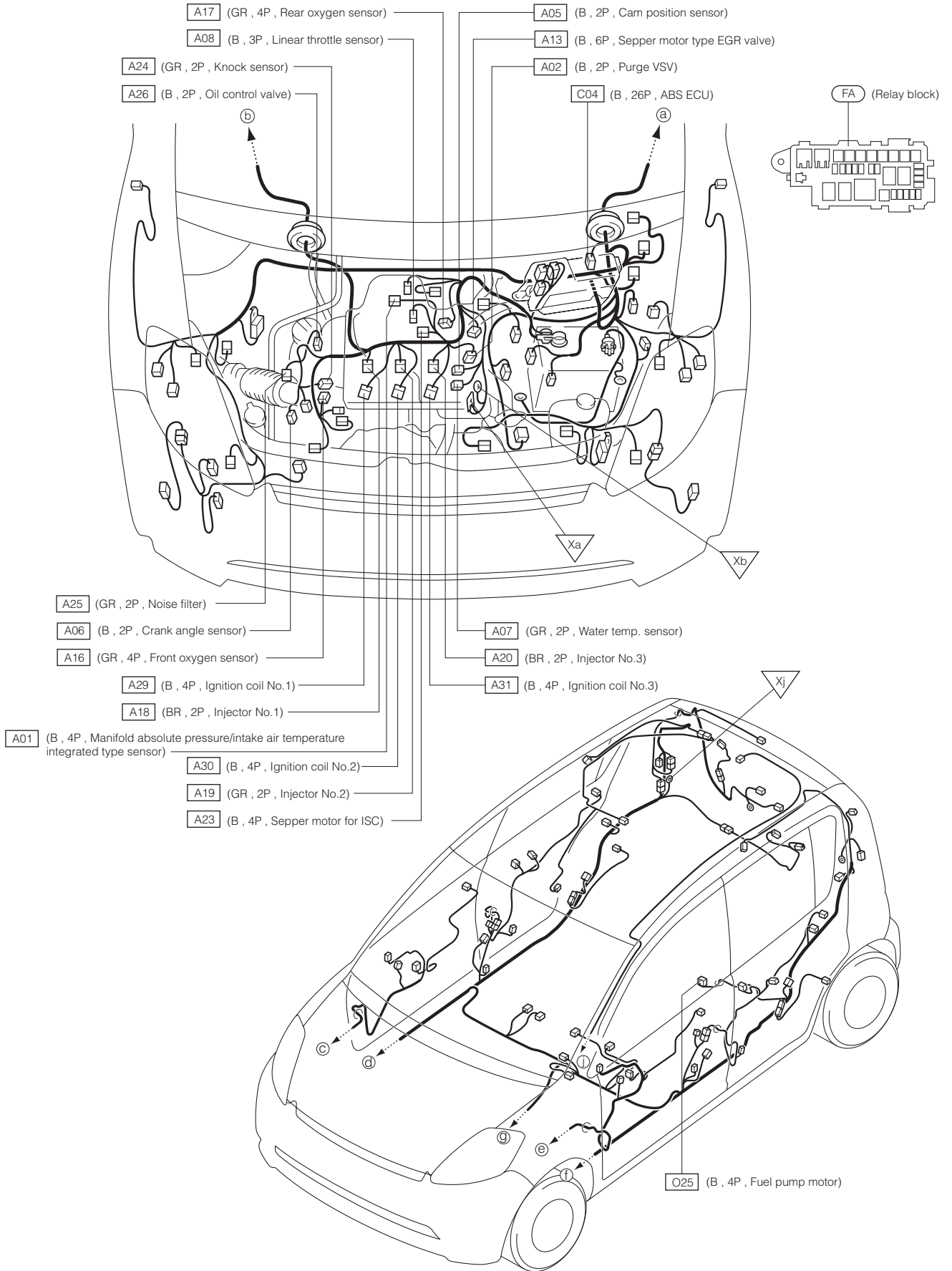

4-3 RHD VEHICLE(K3-VE ENGINE)

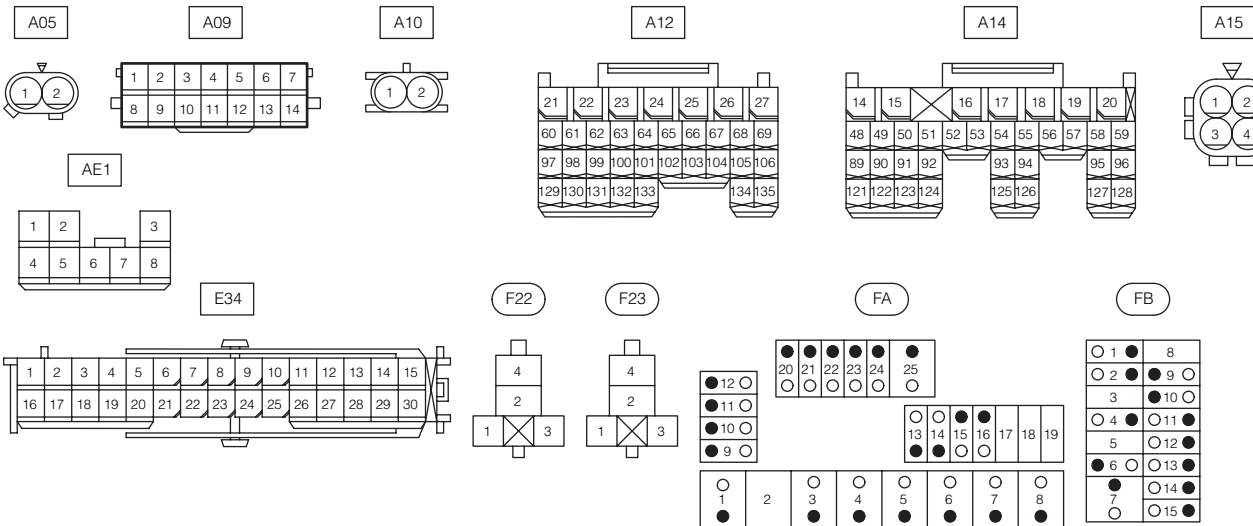
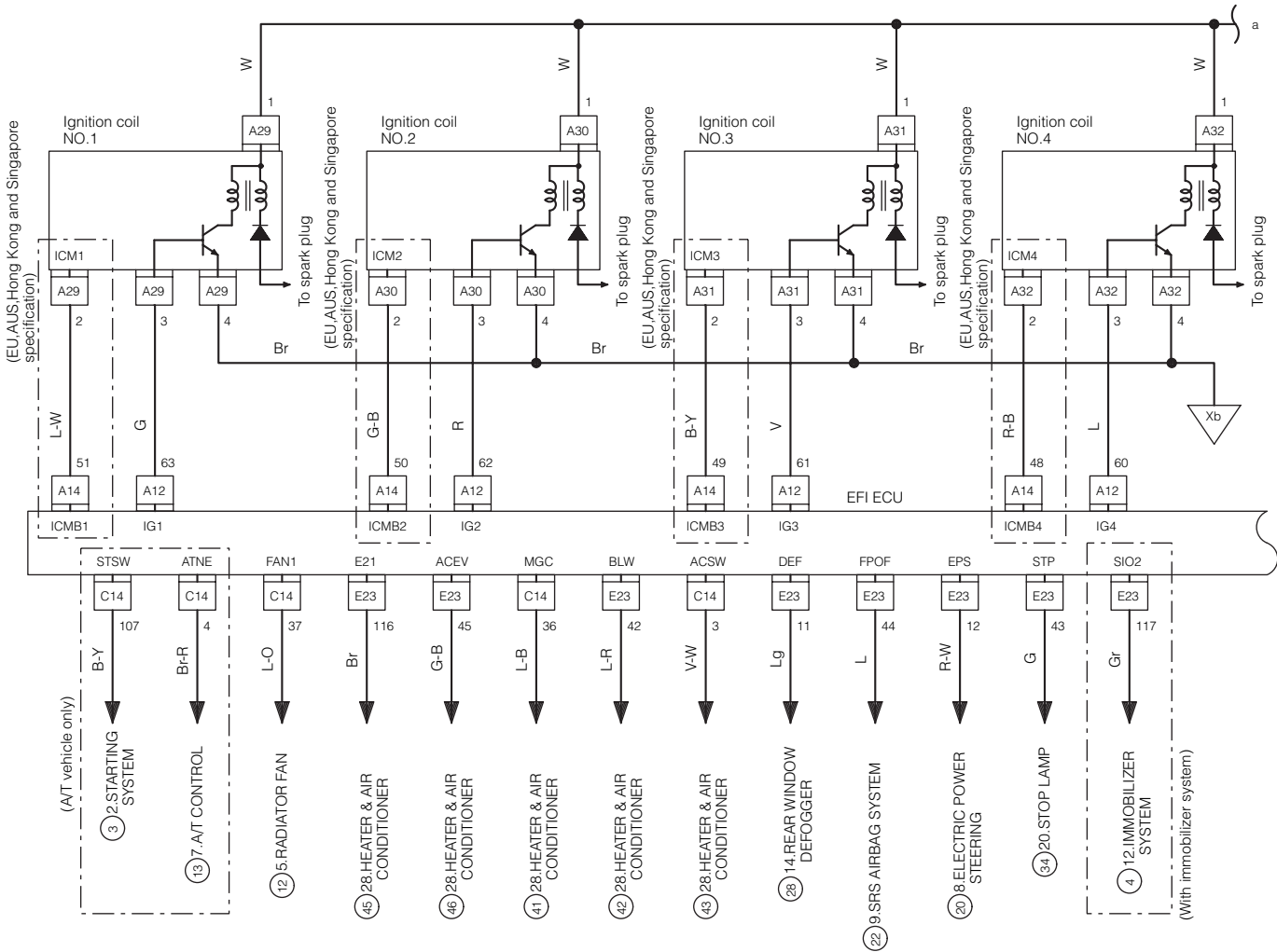

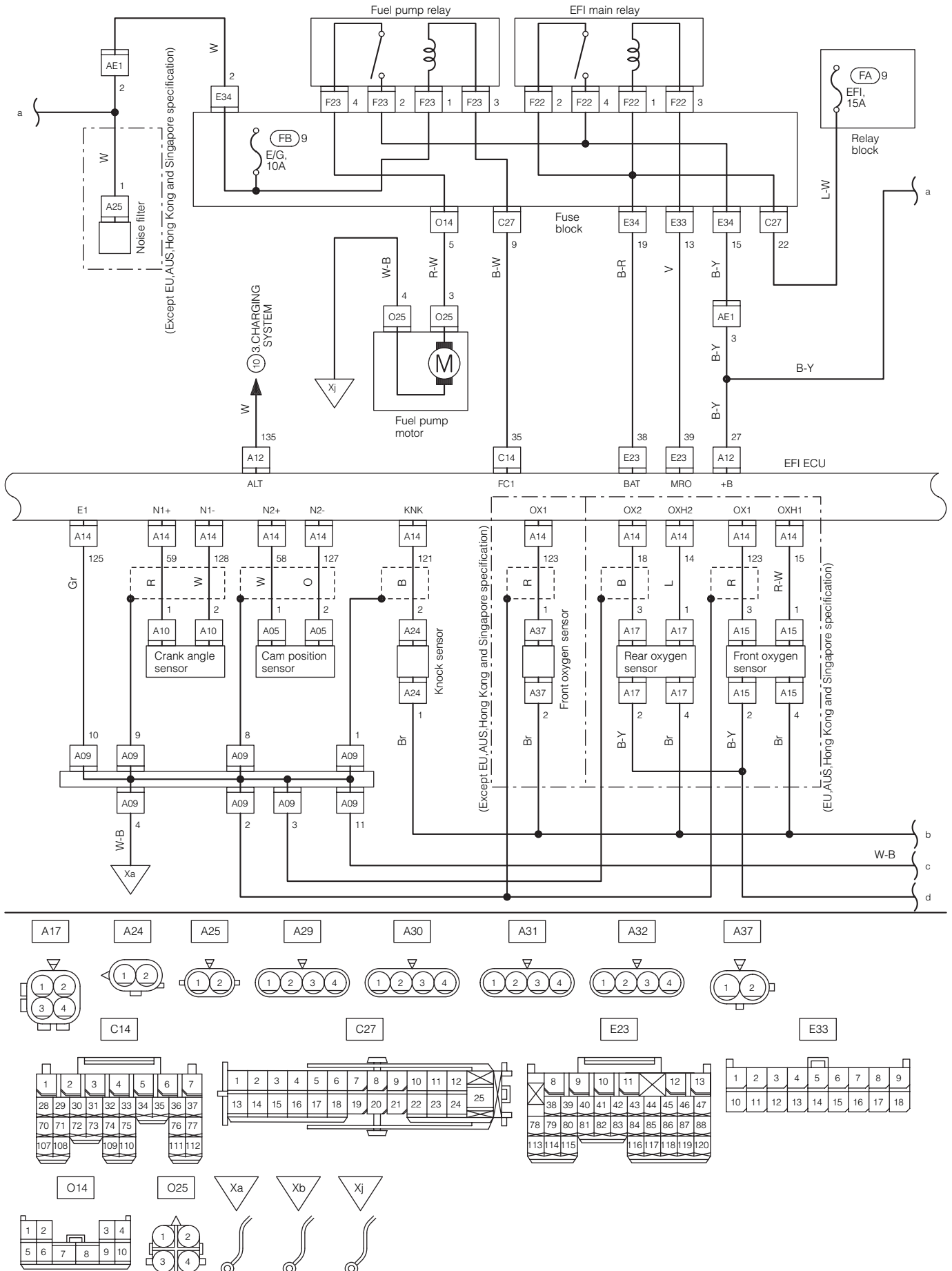

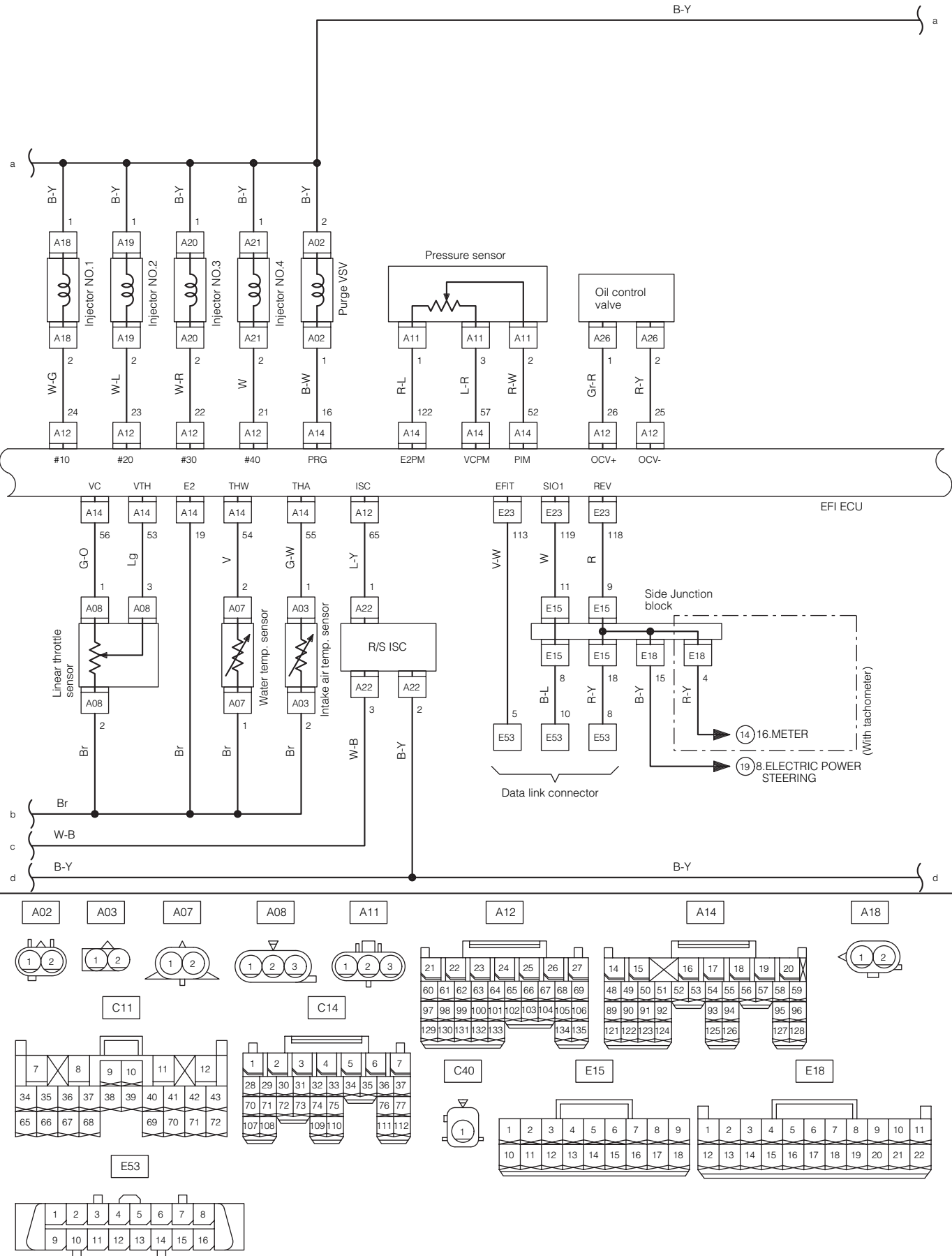

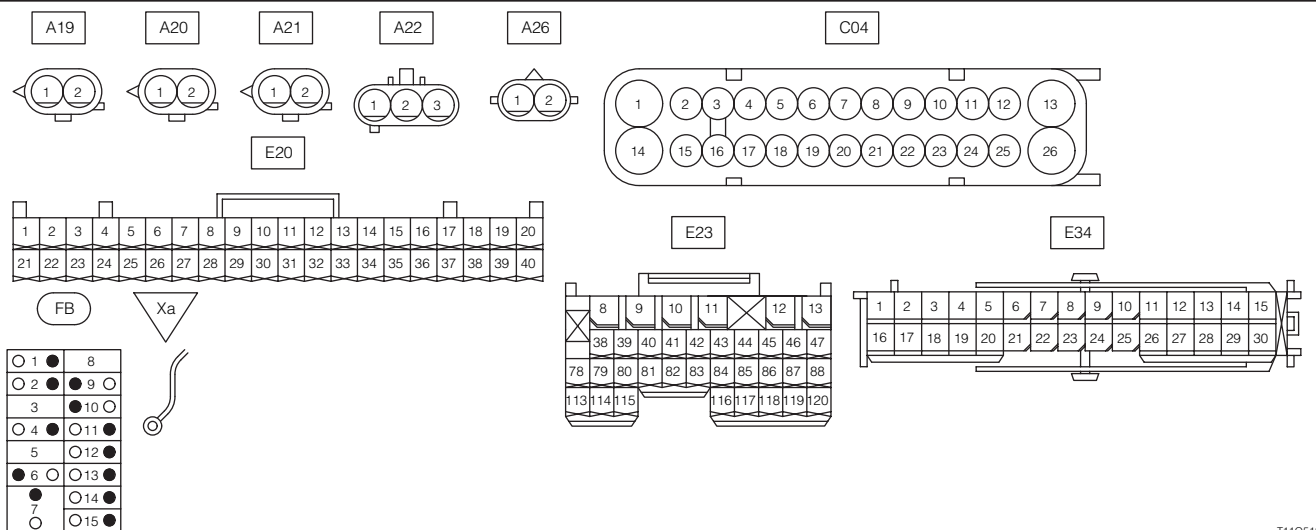
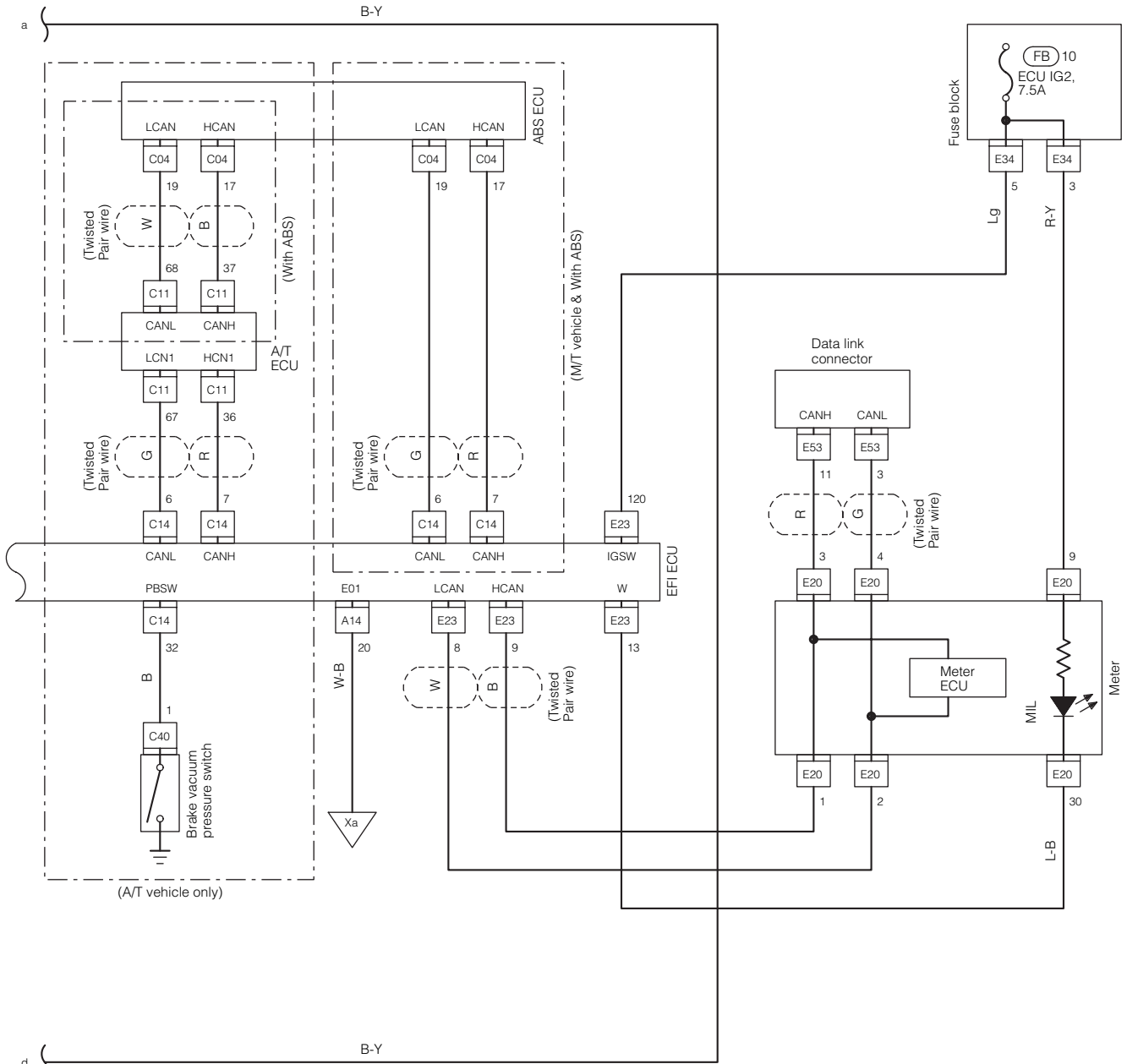

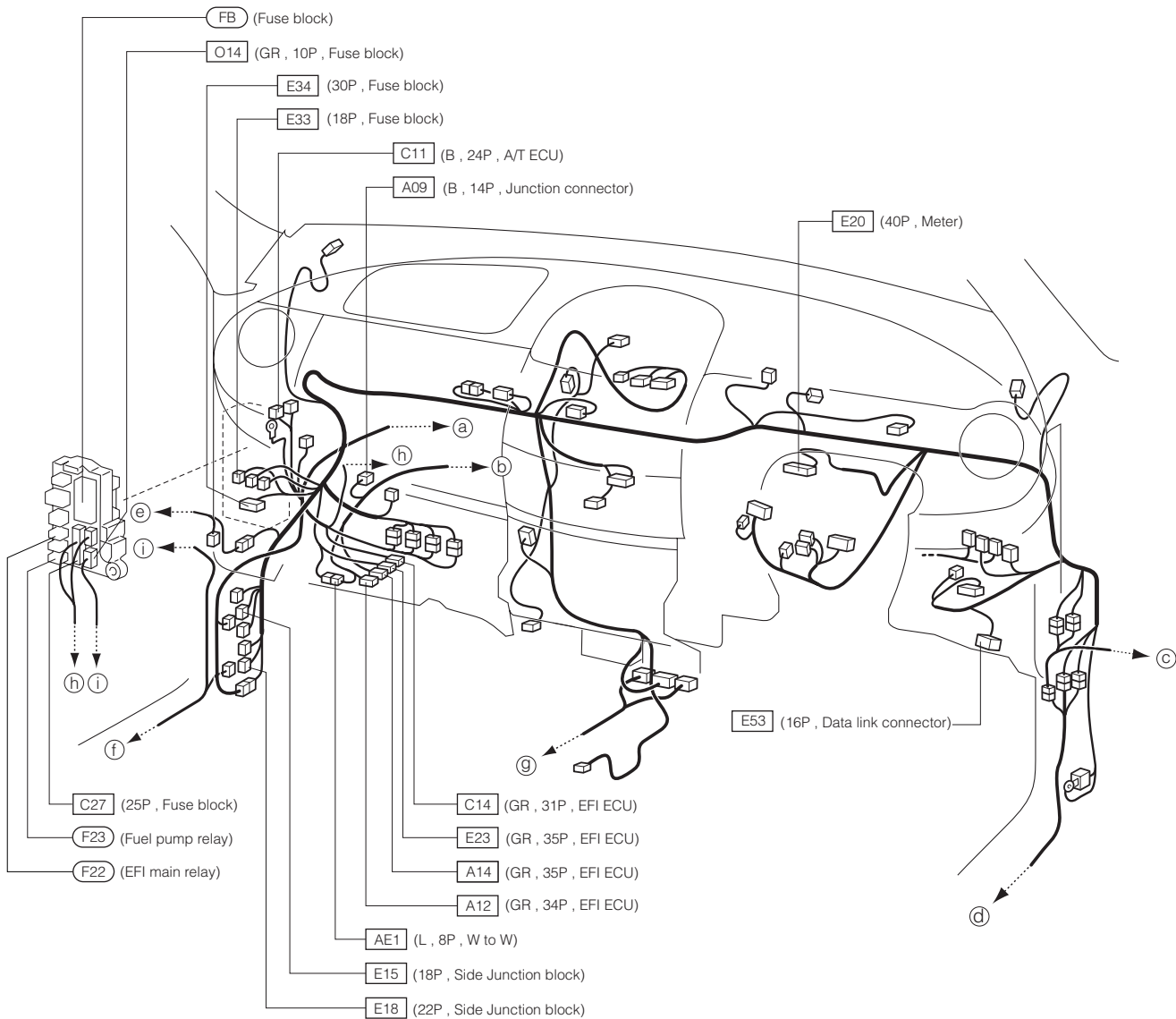

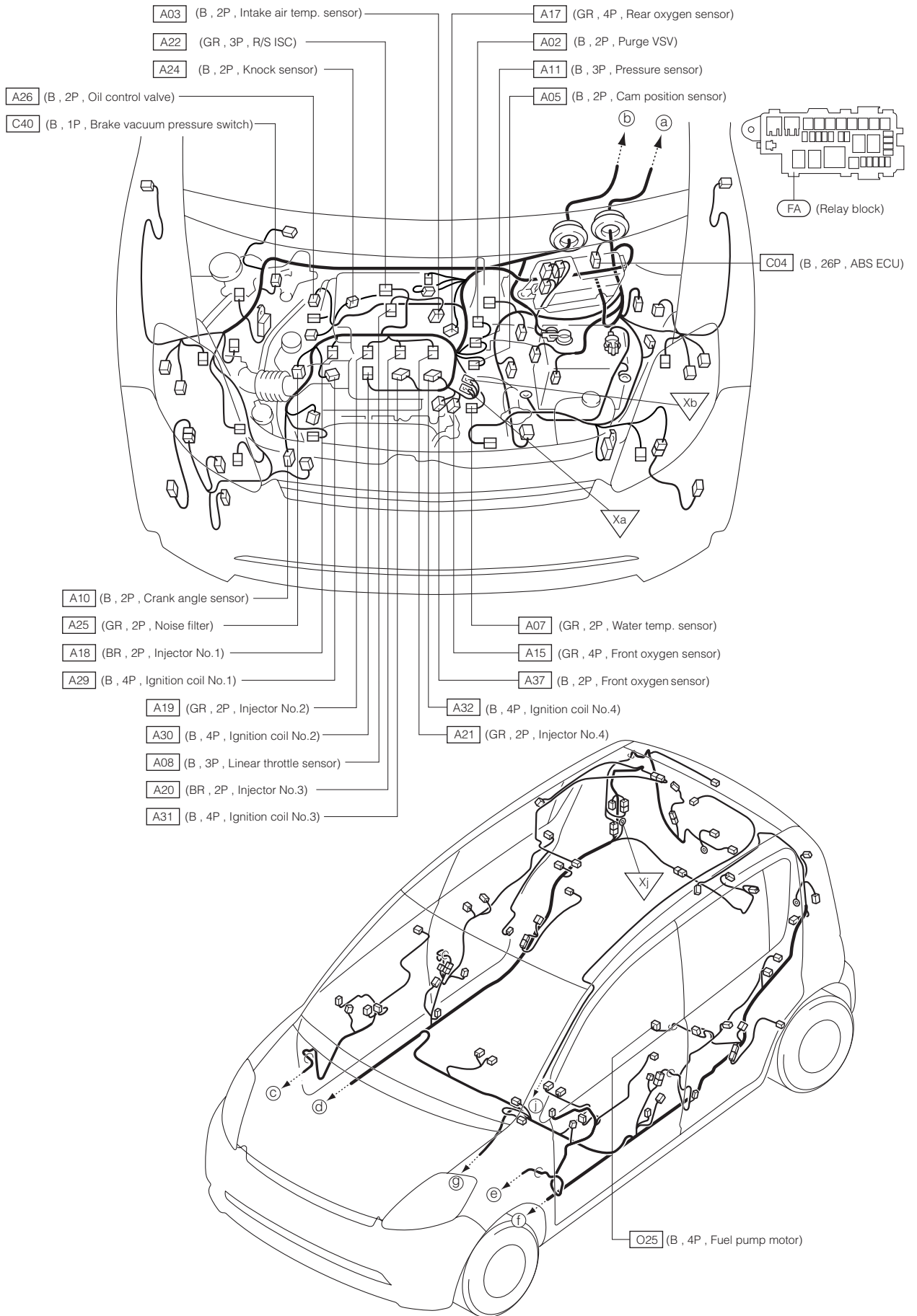

4-4 LHD VEHICLE(K3-VE ENGINE)

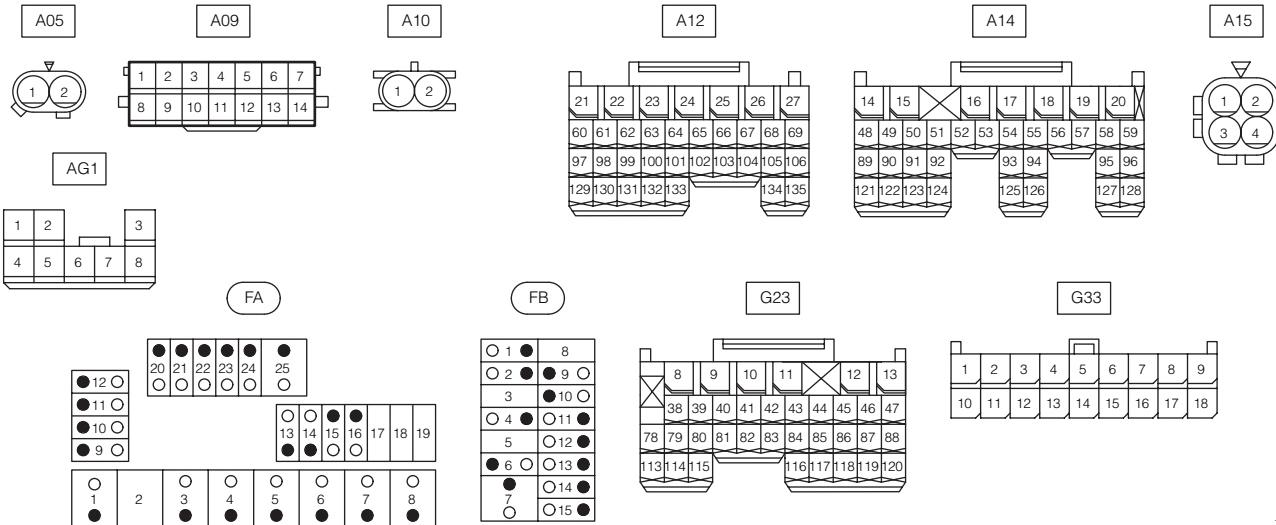
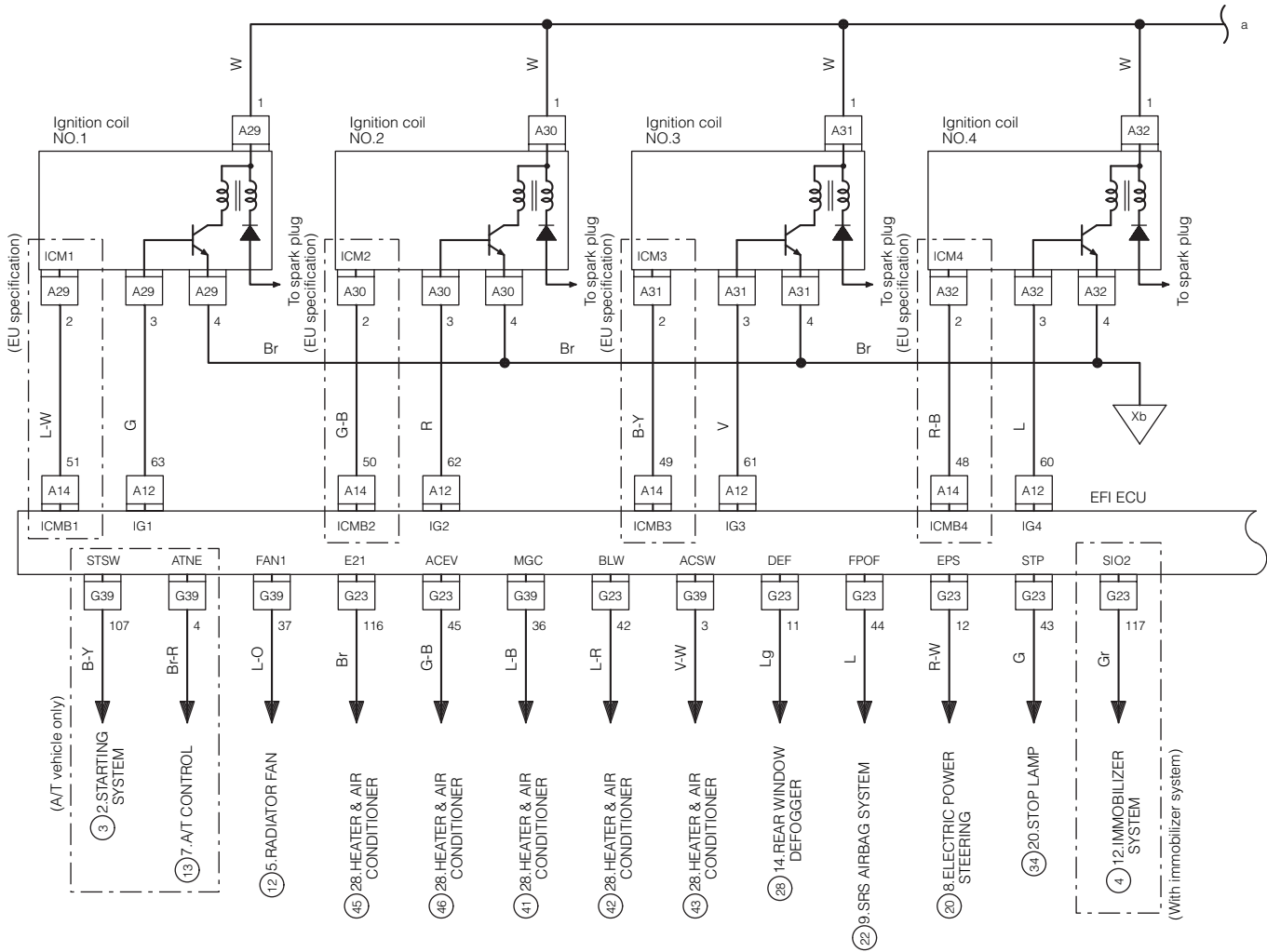

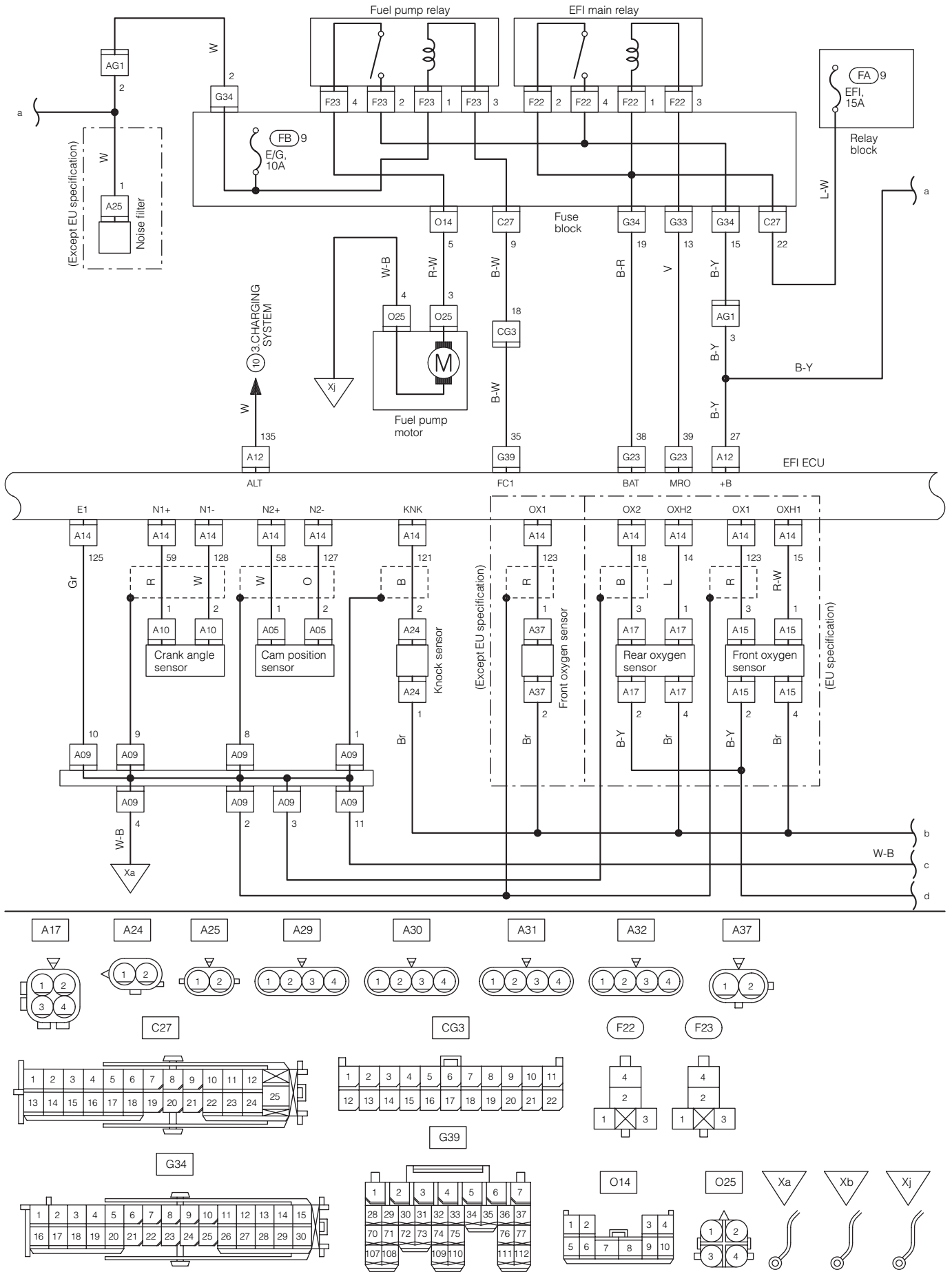

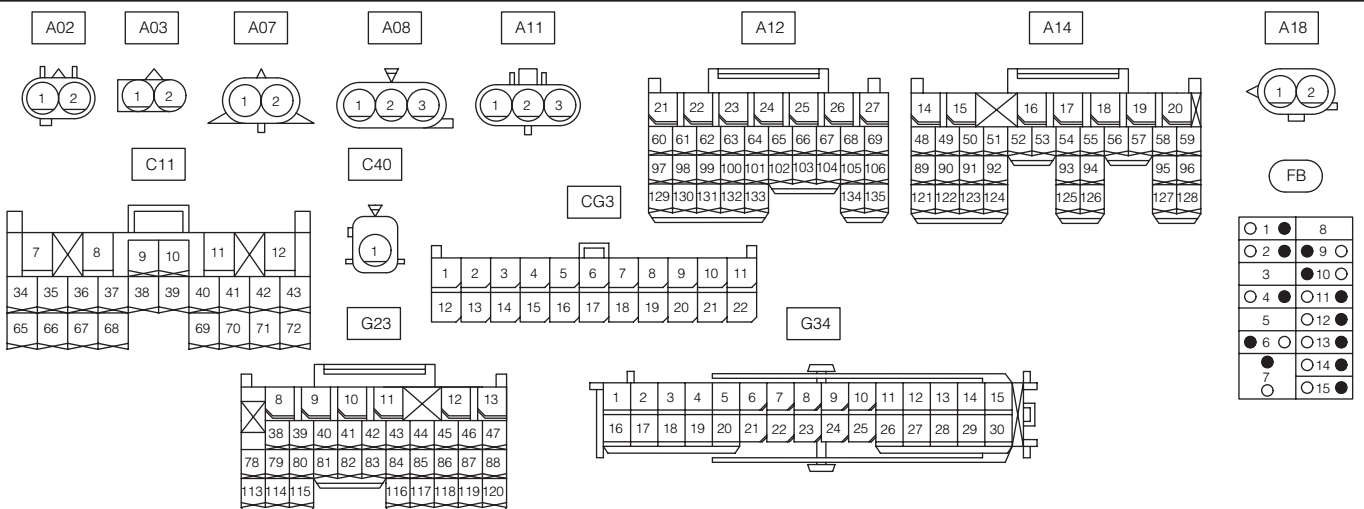
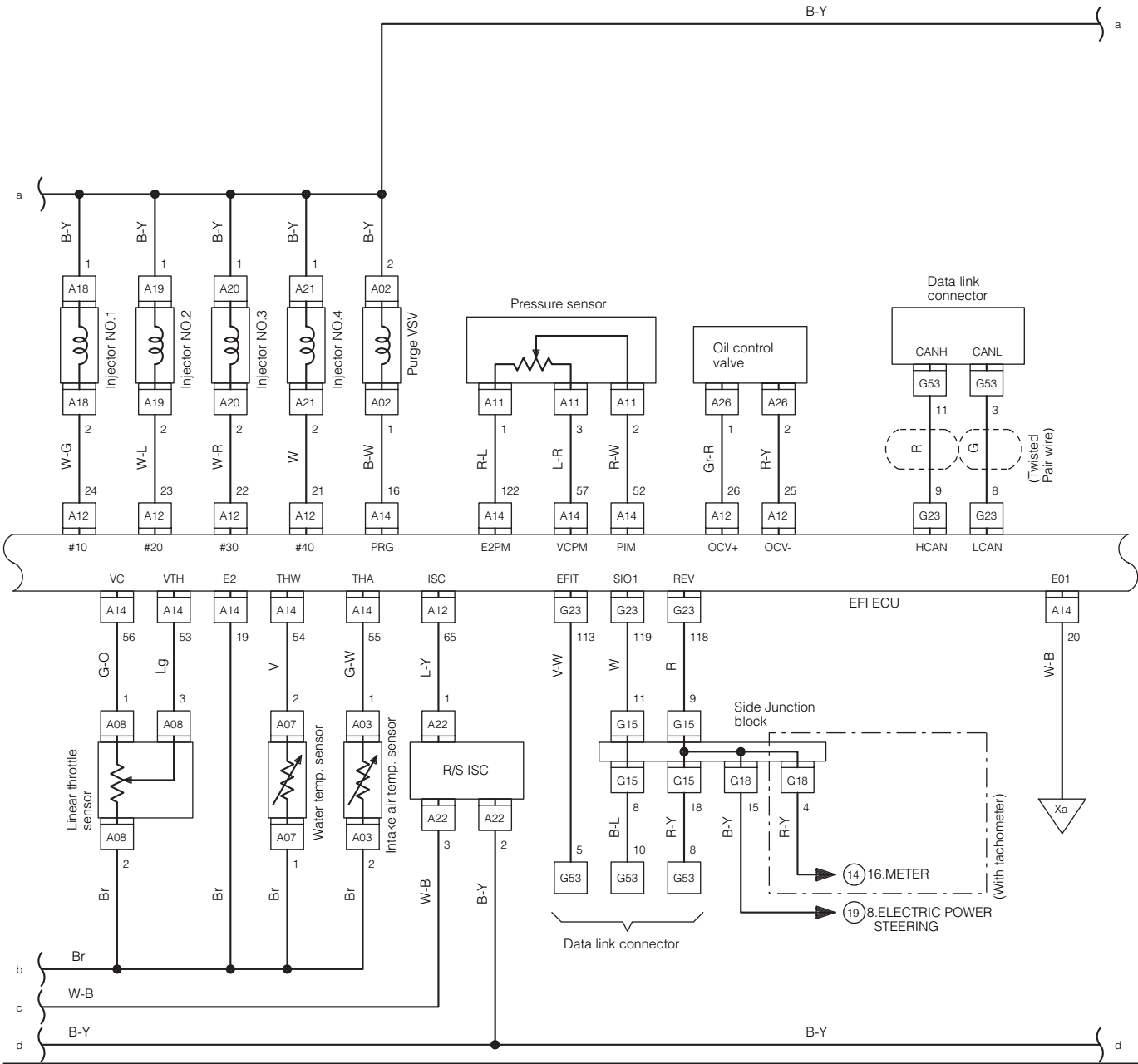

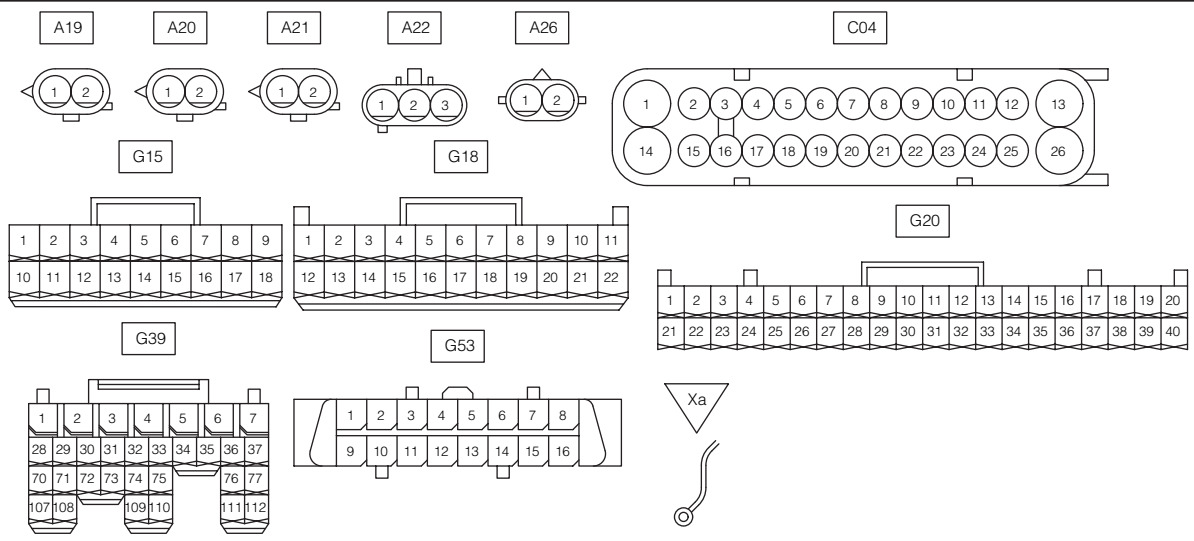
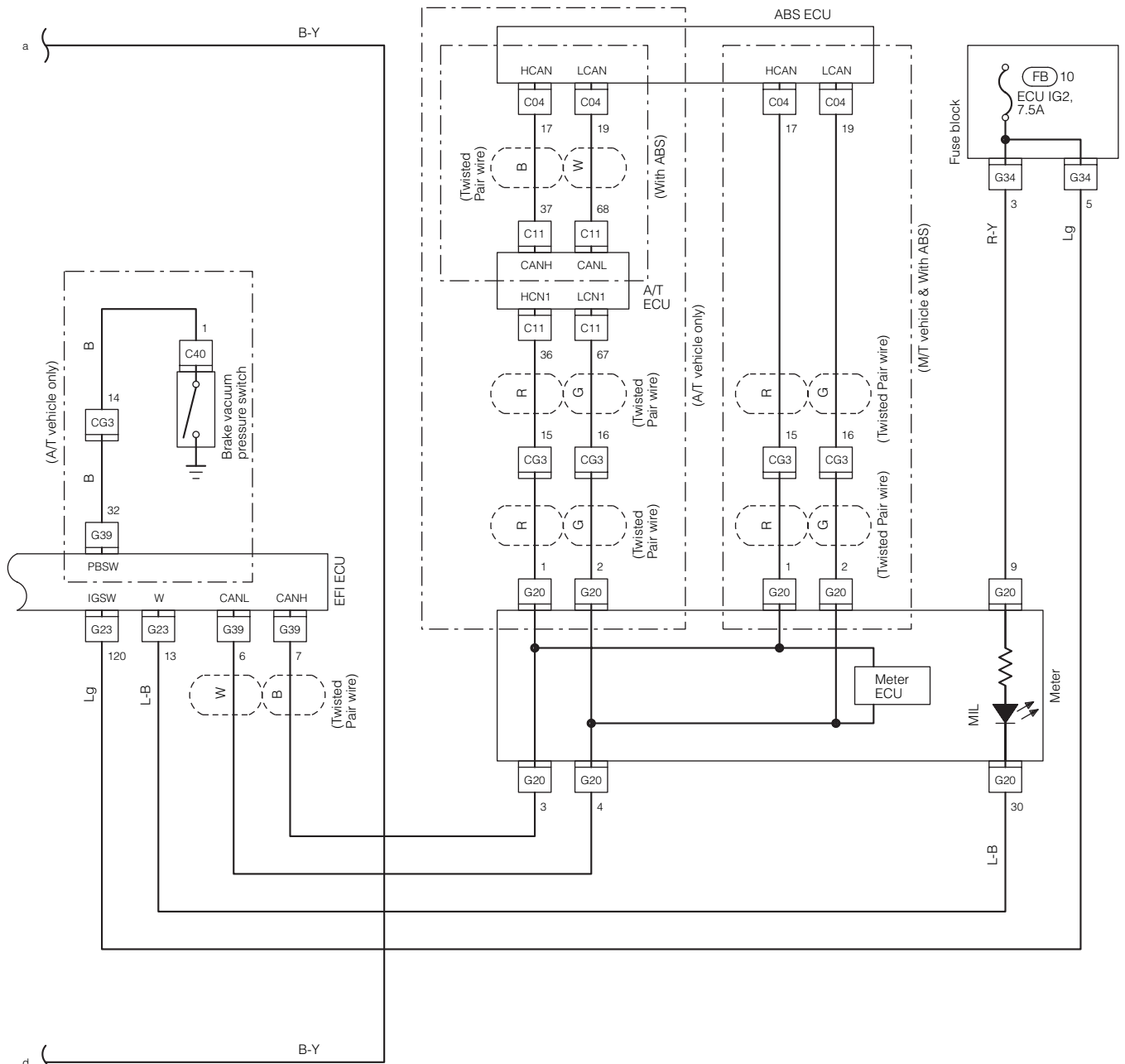

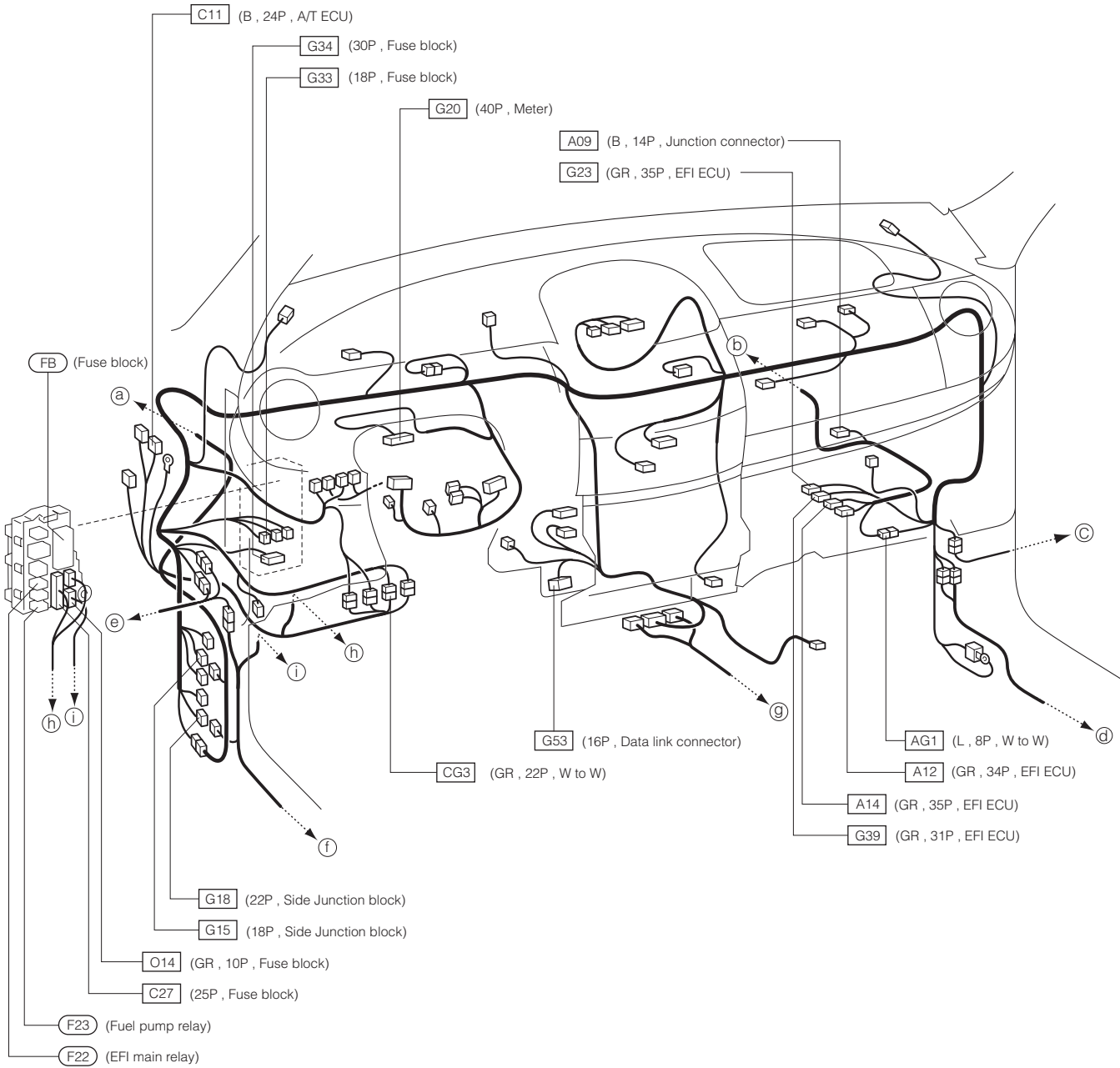

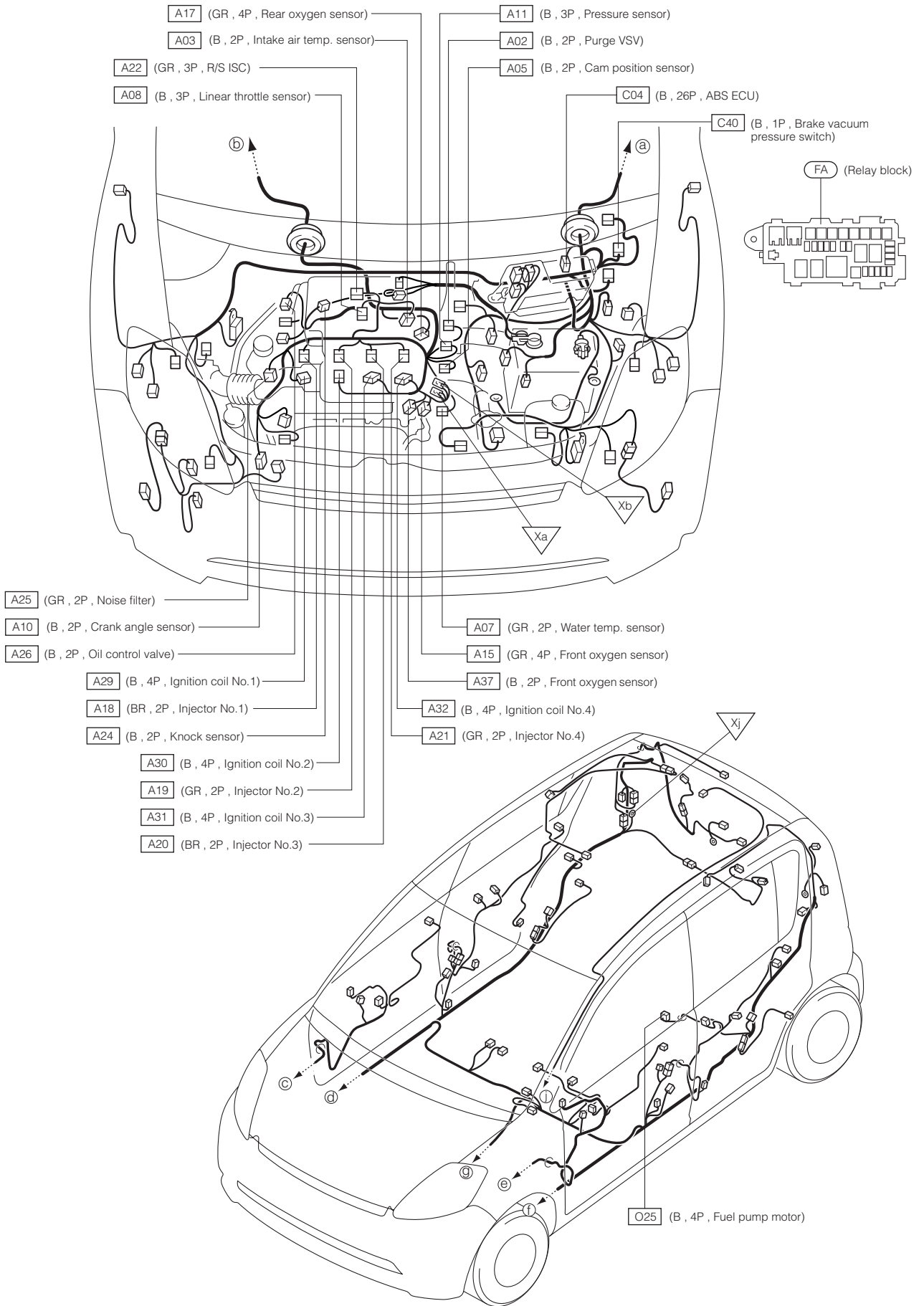

5 RADIATOR FAN 5-1 RHD VEHICLE

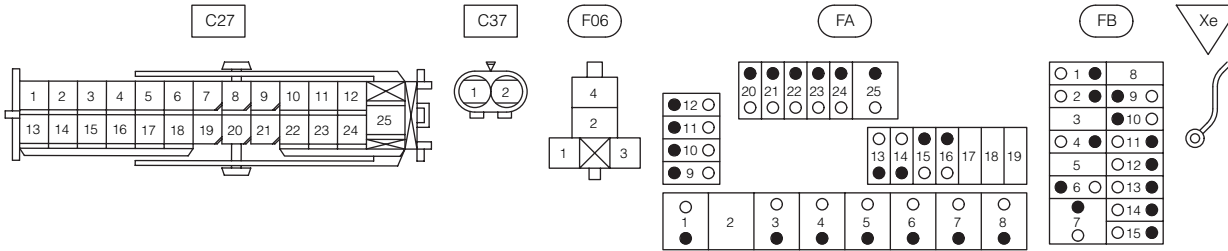
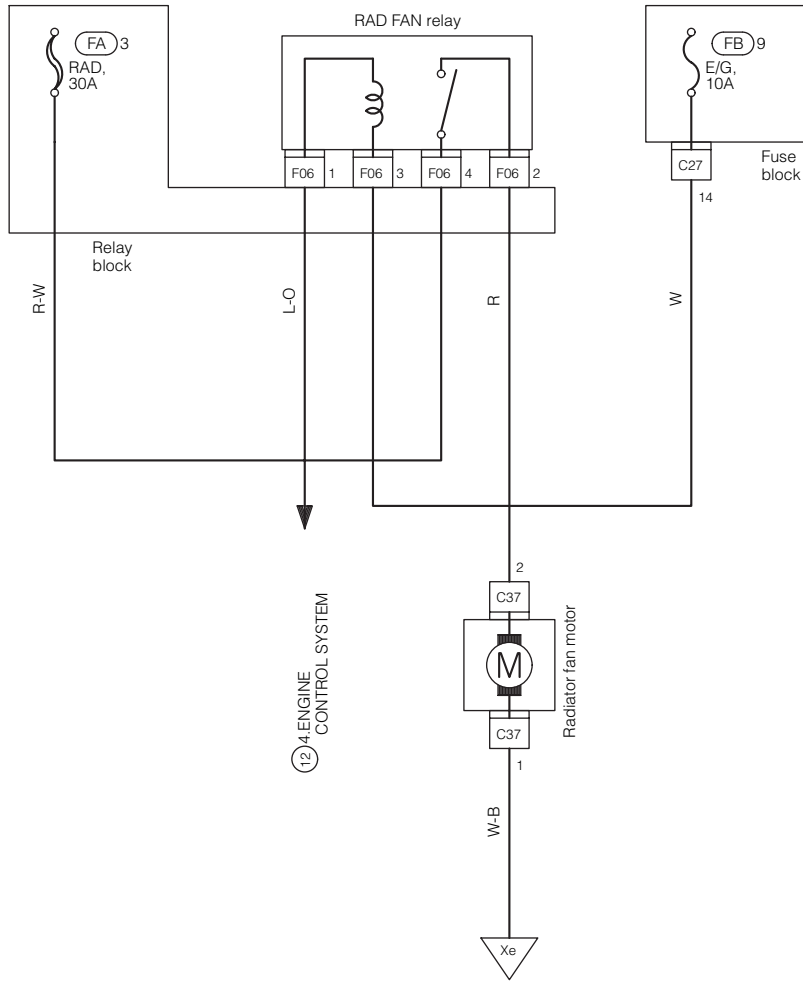

(MEMO)

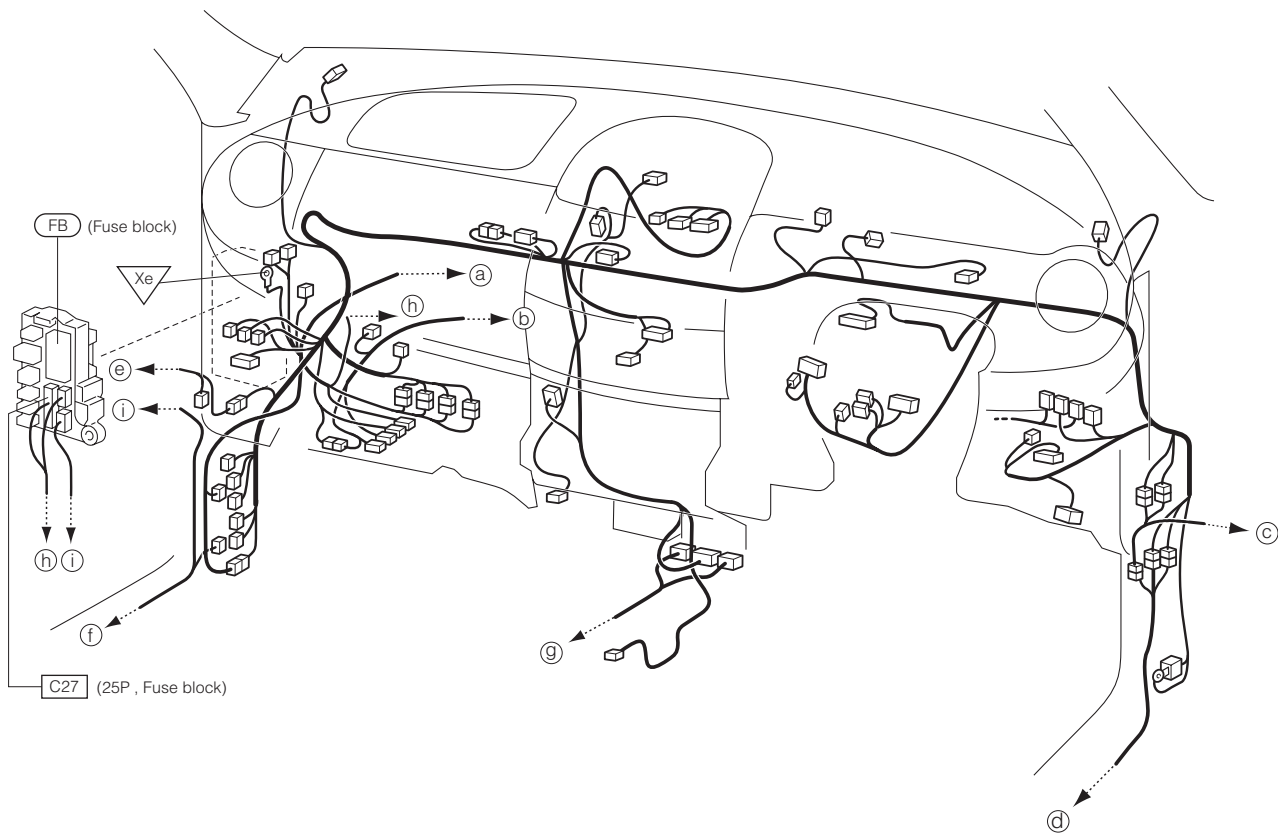

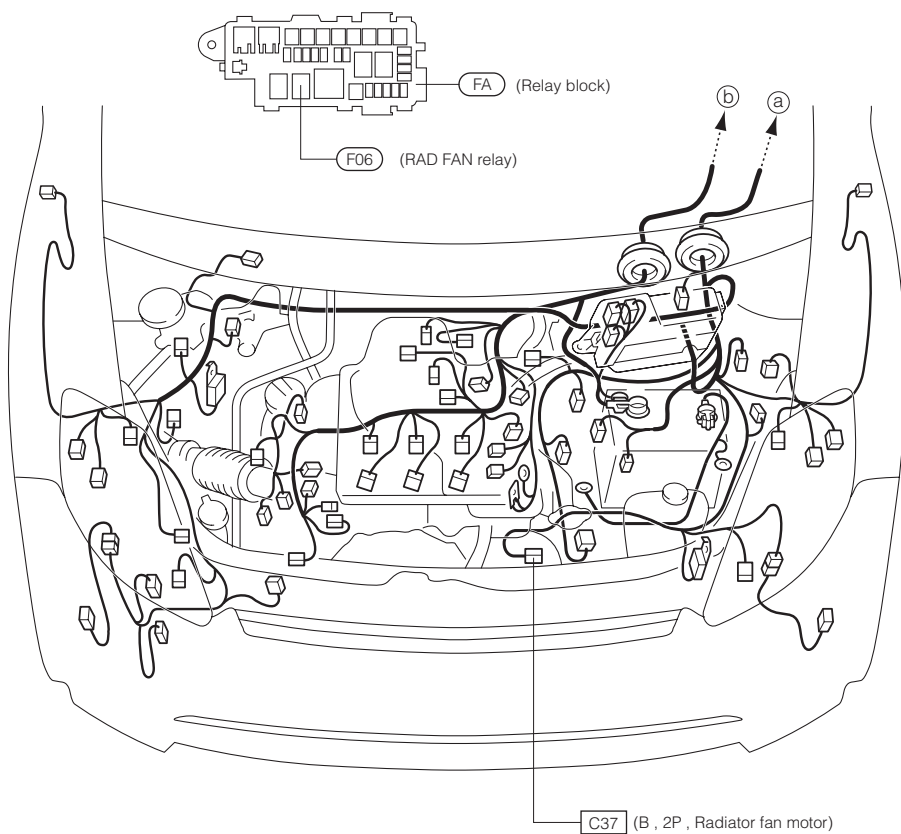

5-2 LHD VEHICLE

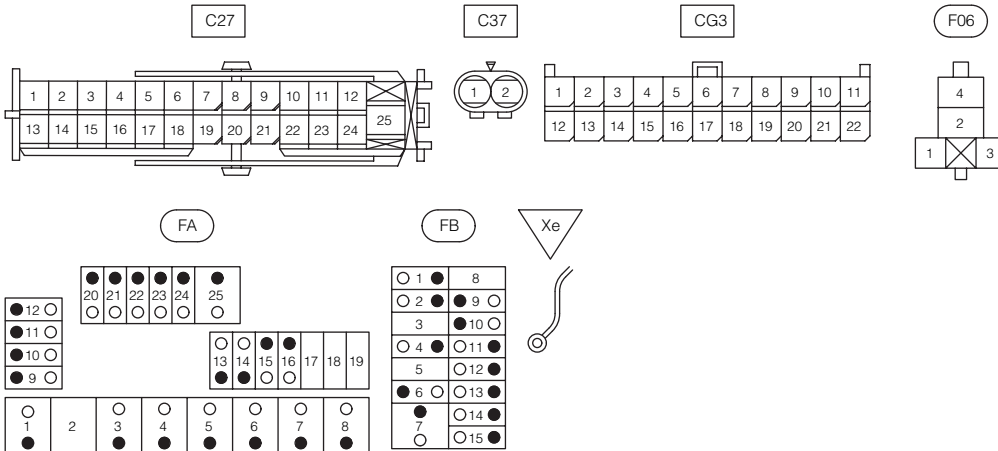
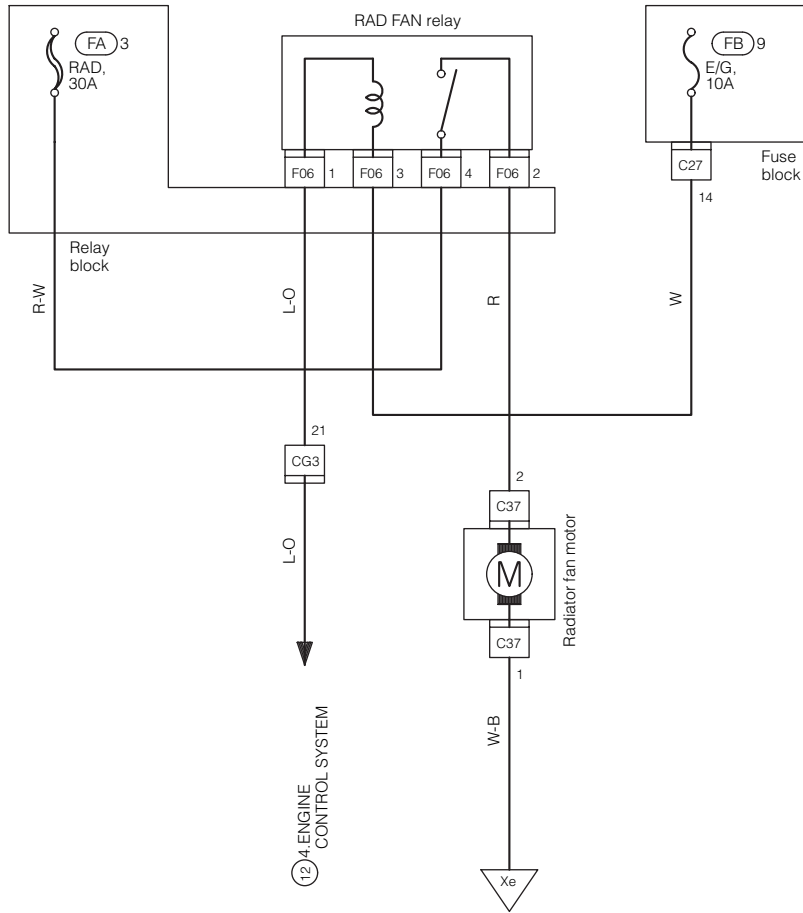

(MEMO)

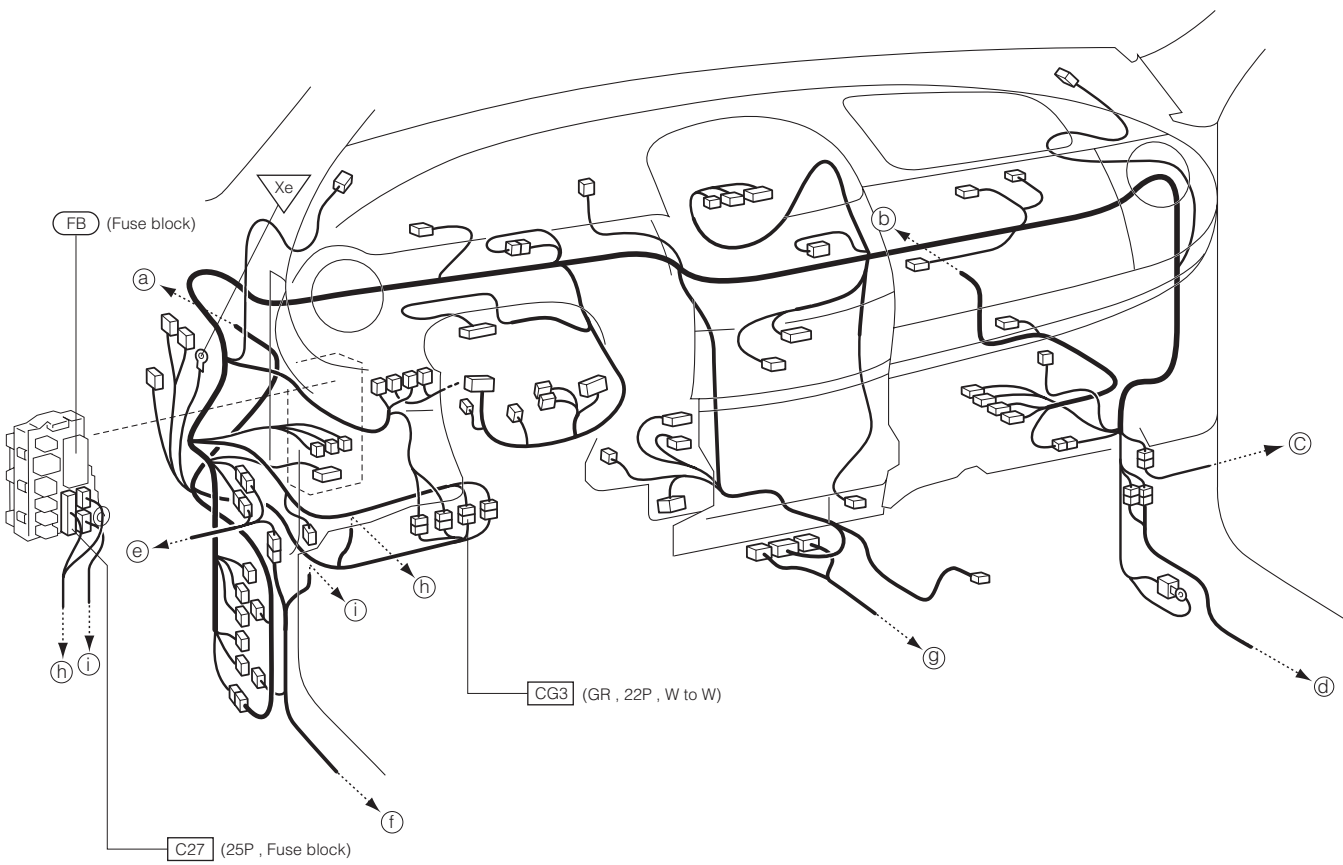

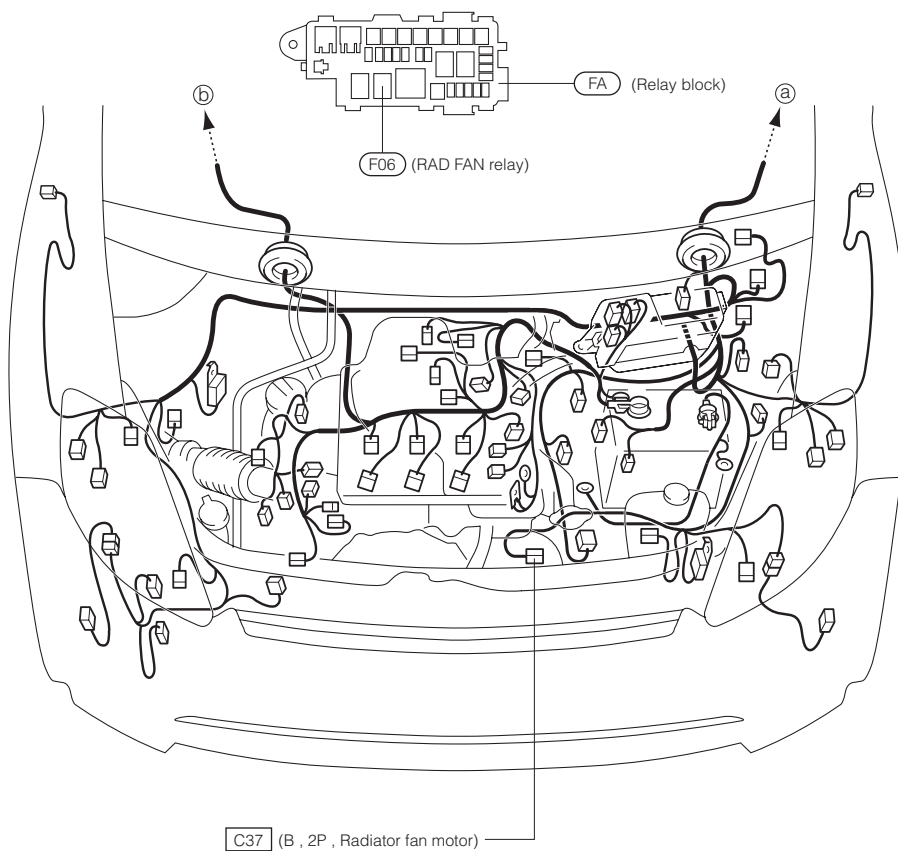

D-61

6 ABS 6-1 RHD VEHICLE

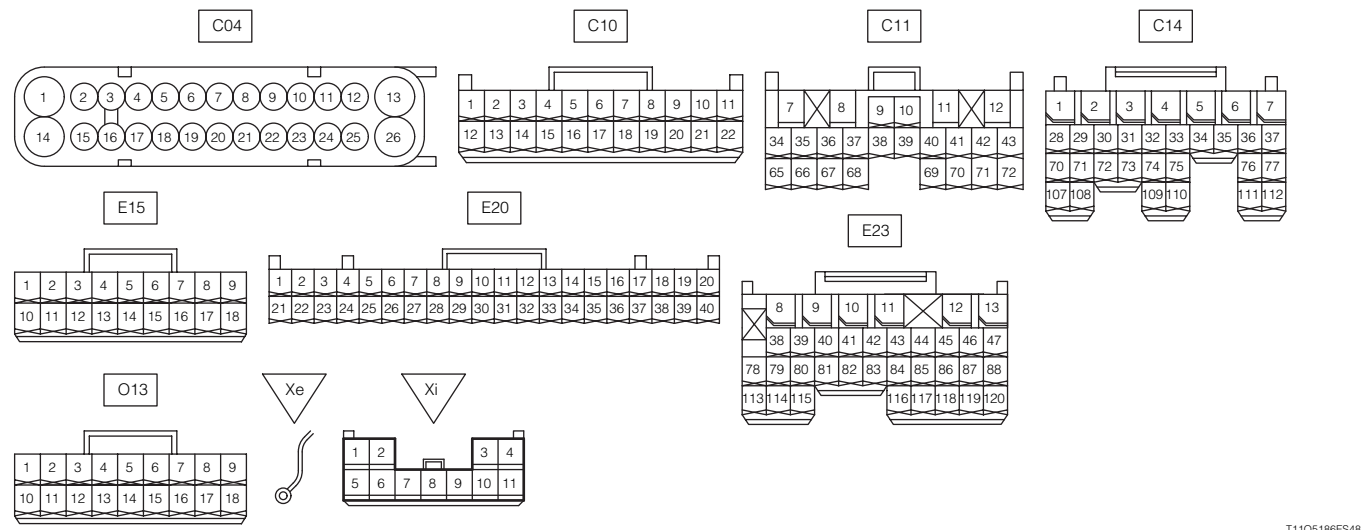
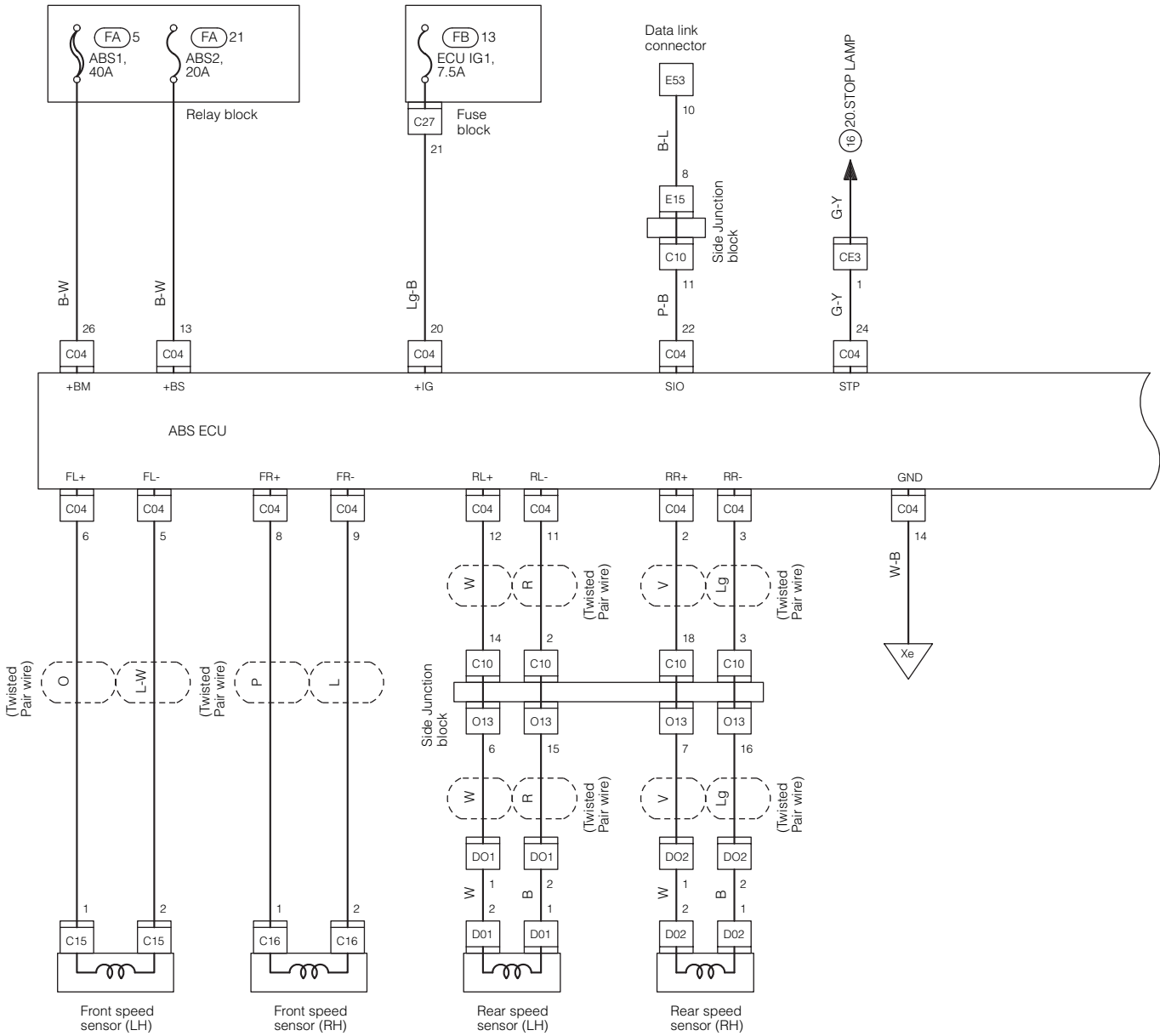

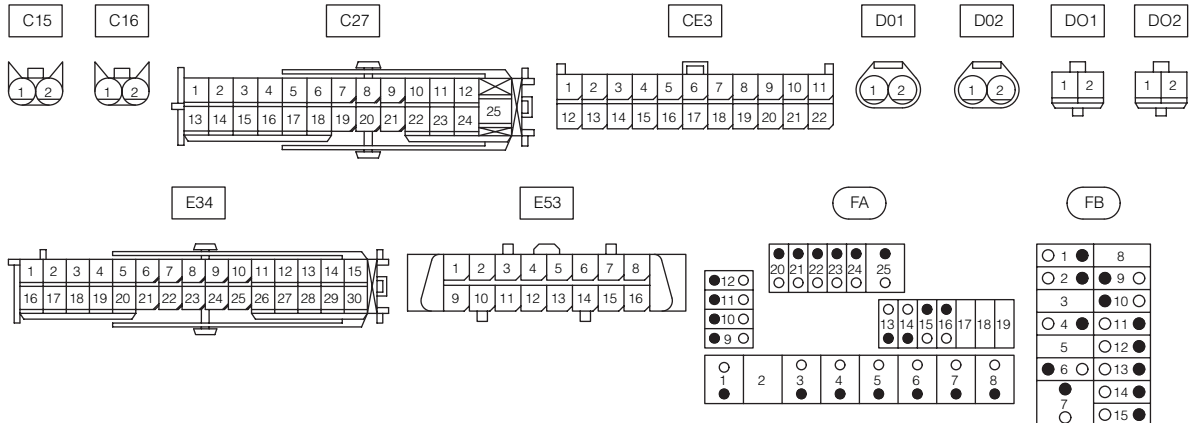
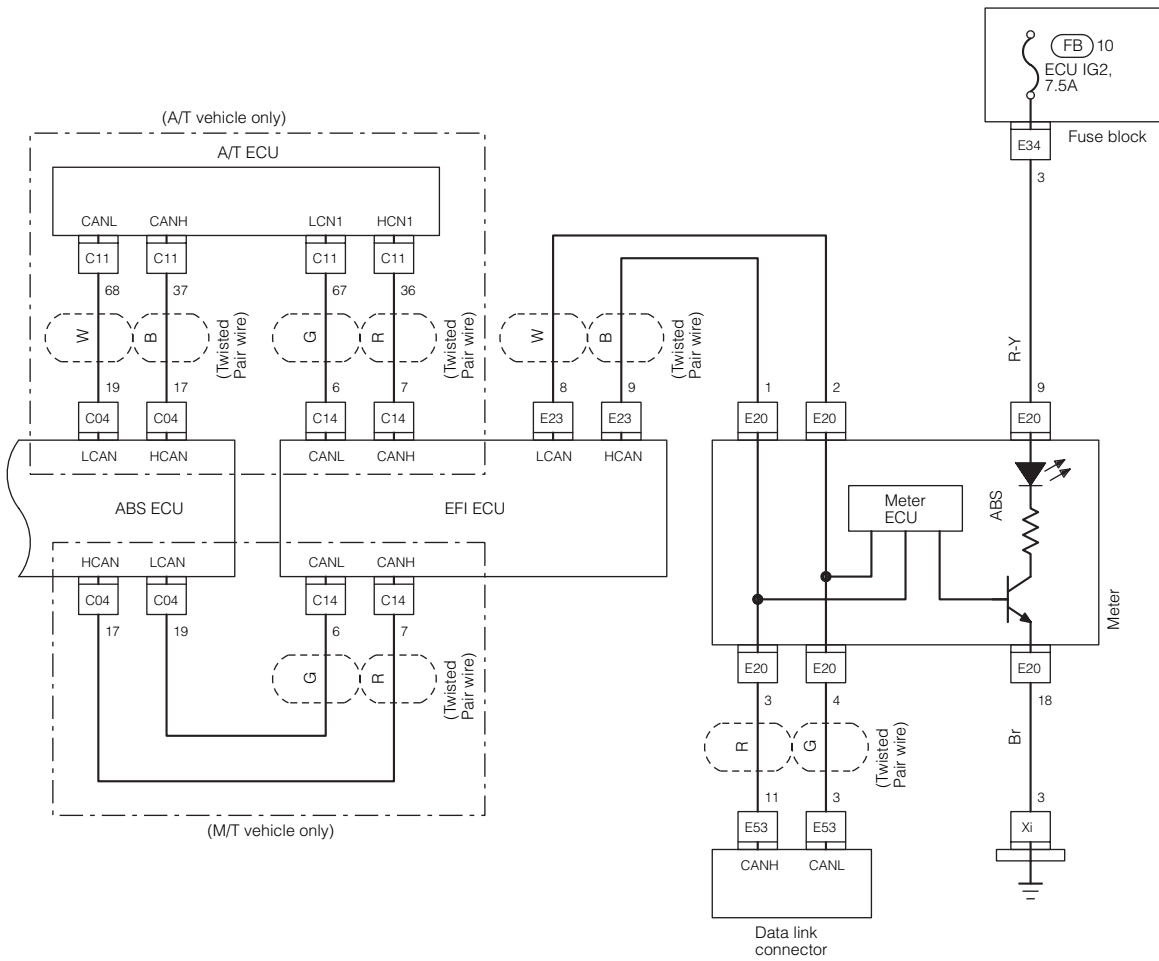

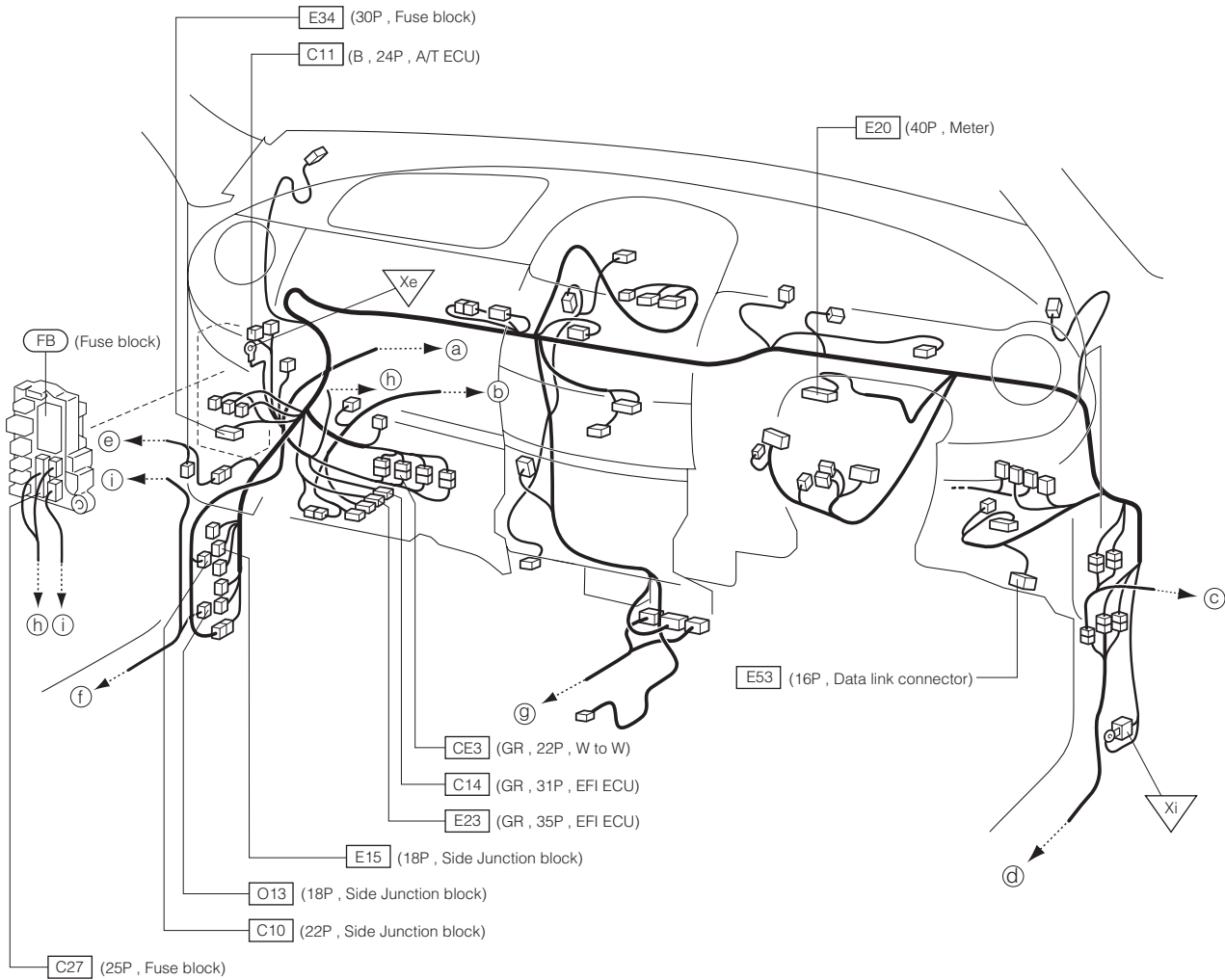

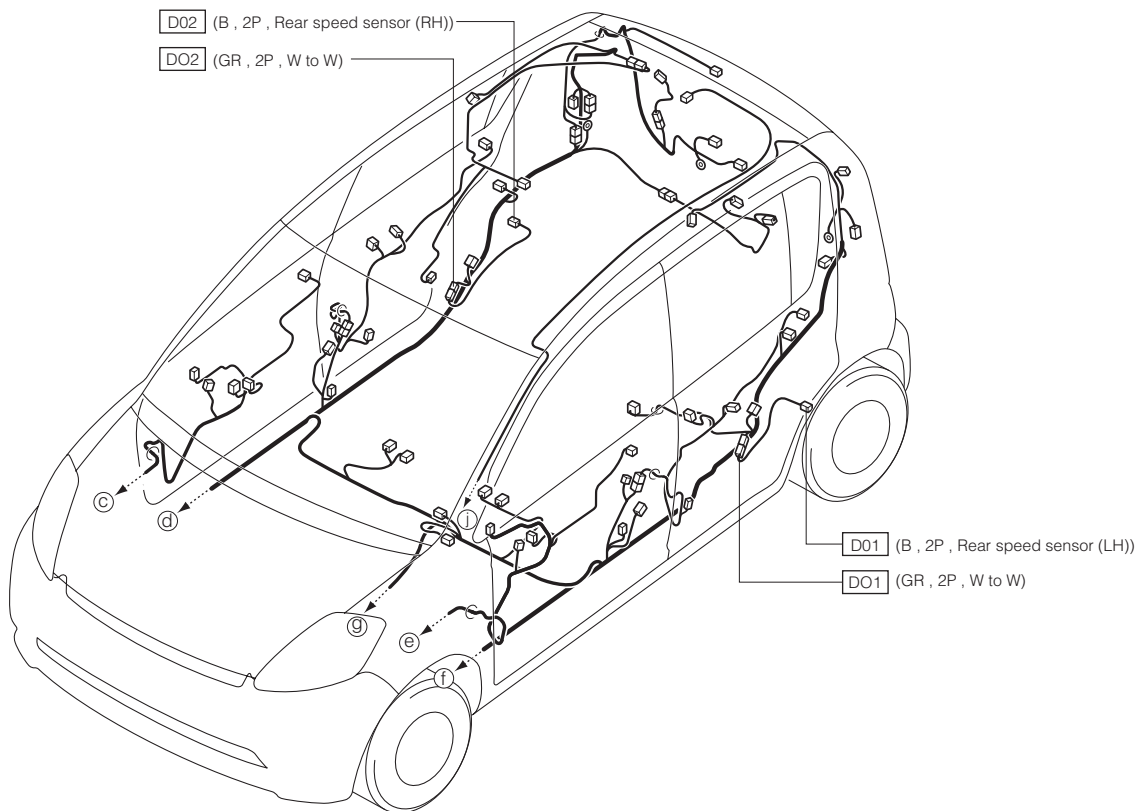
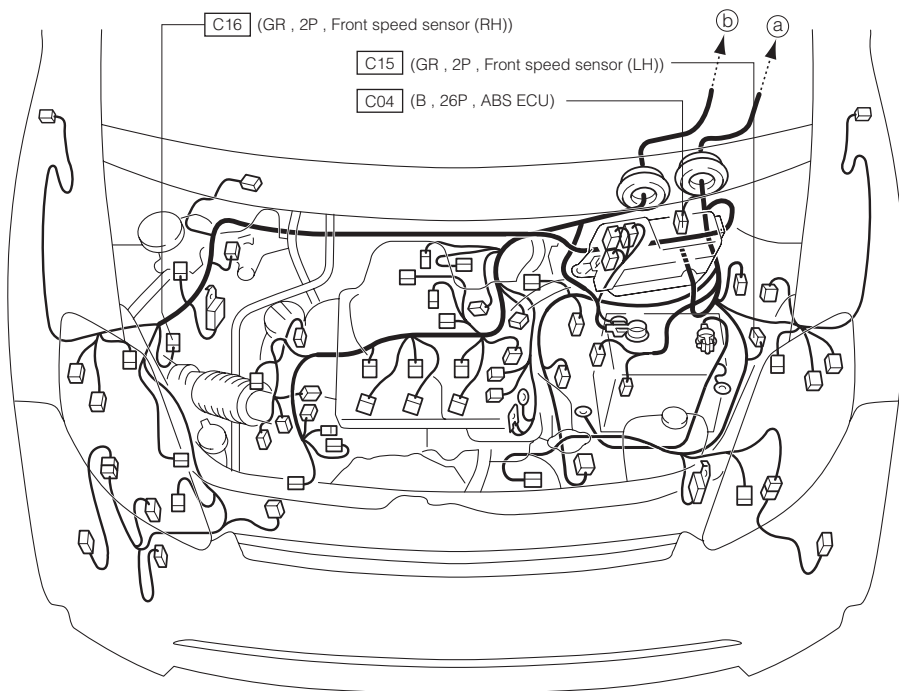
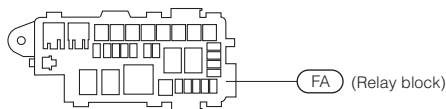

6-2 LHD VEHICLE

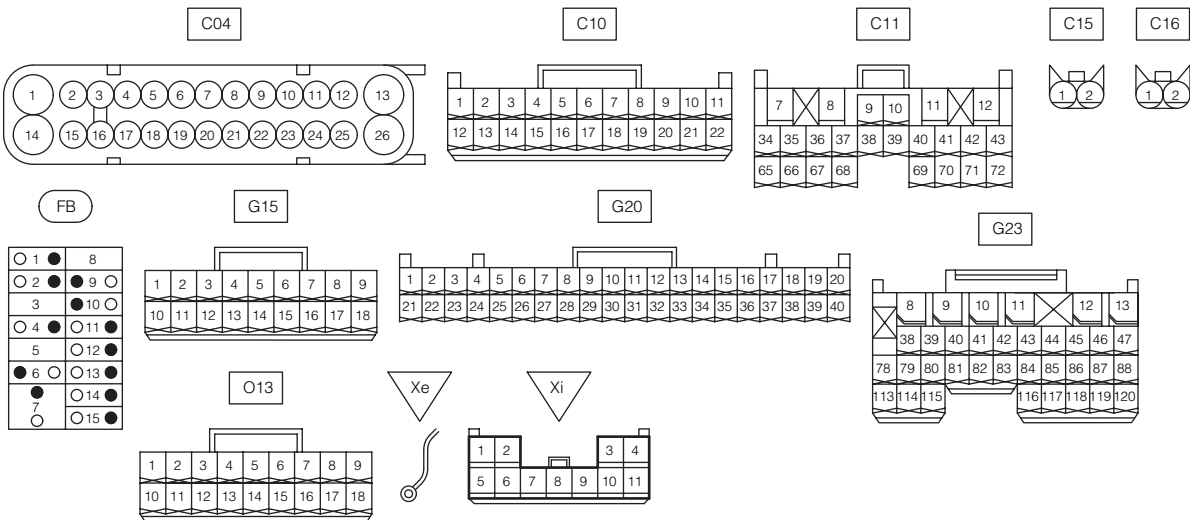
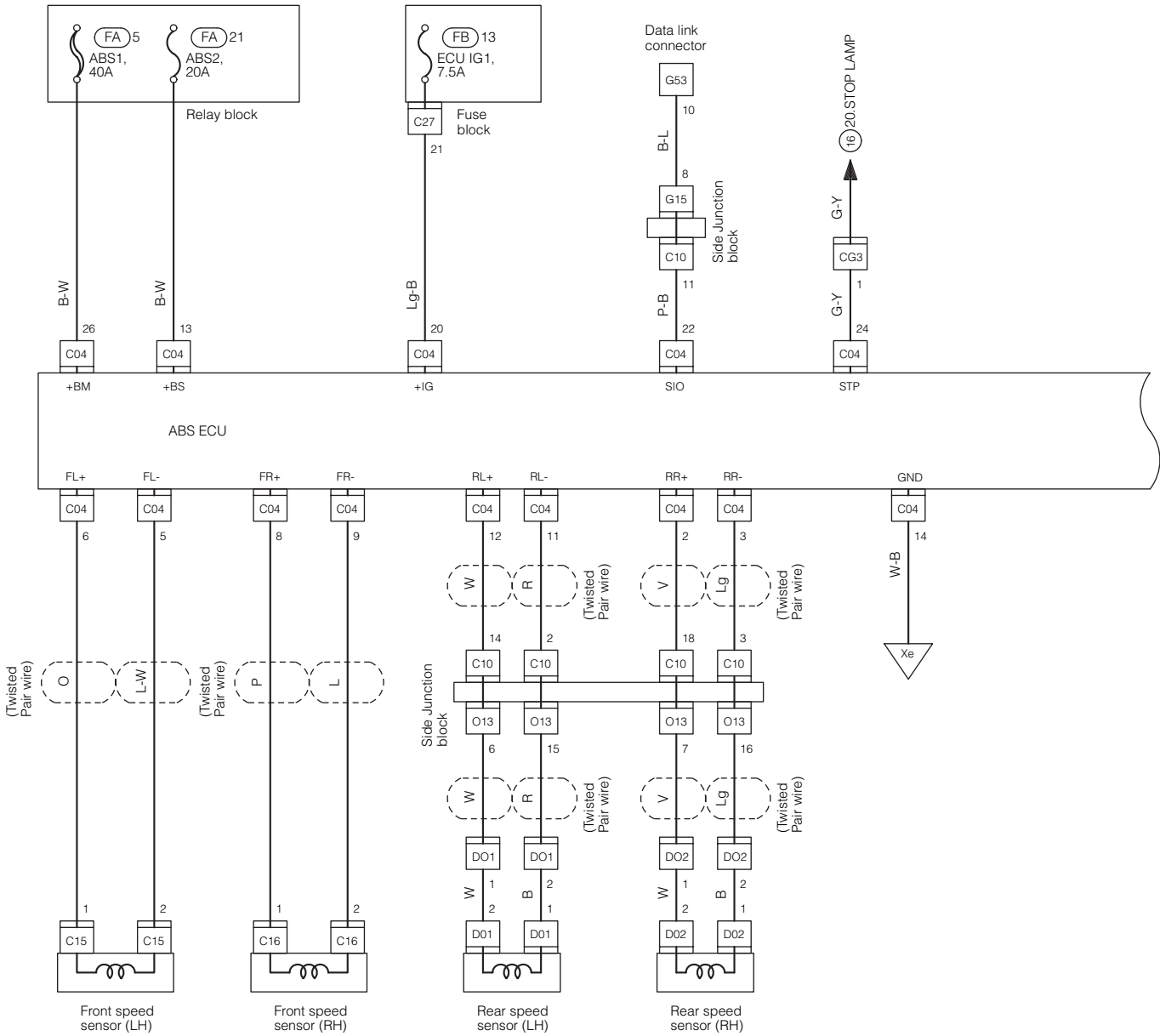

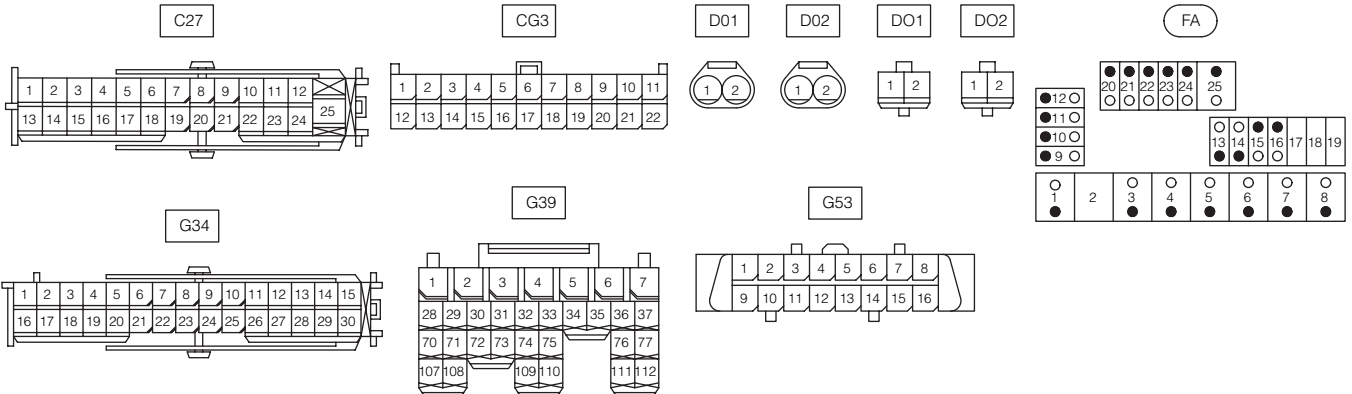
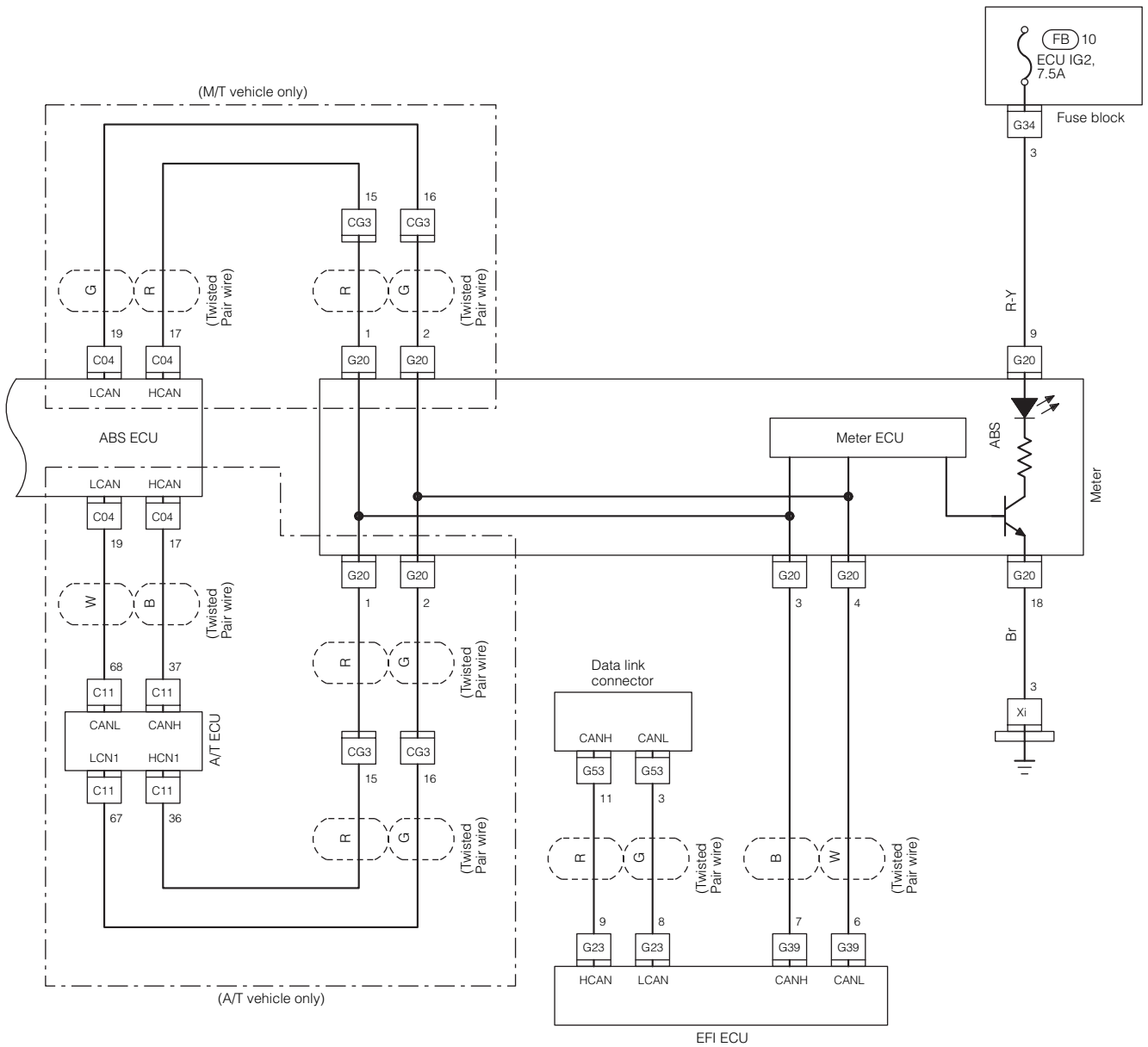

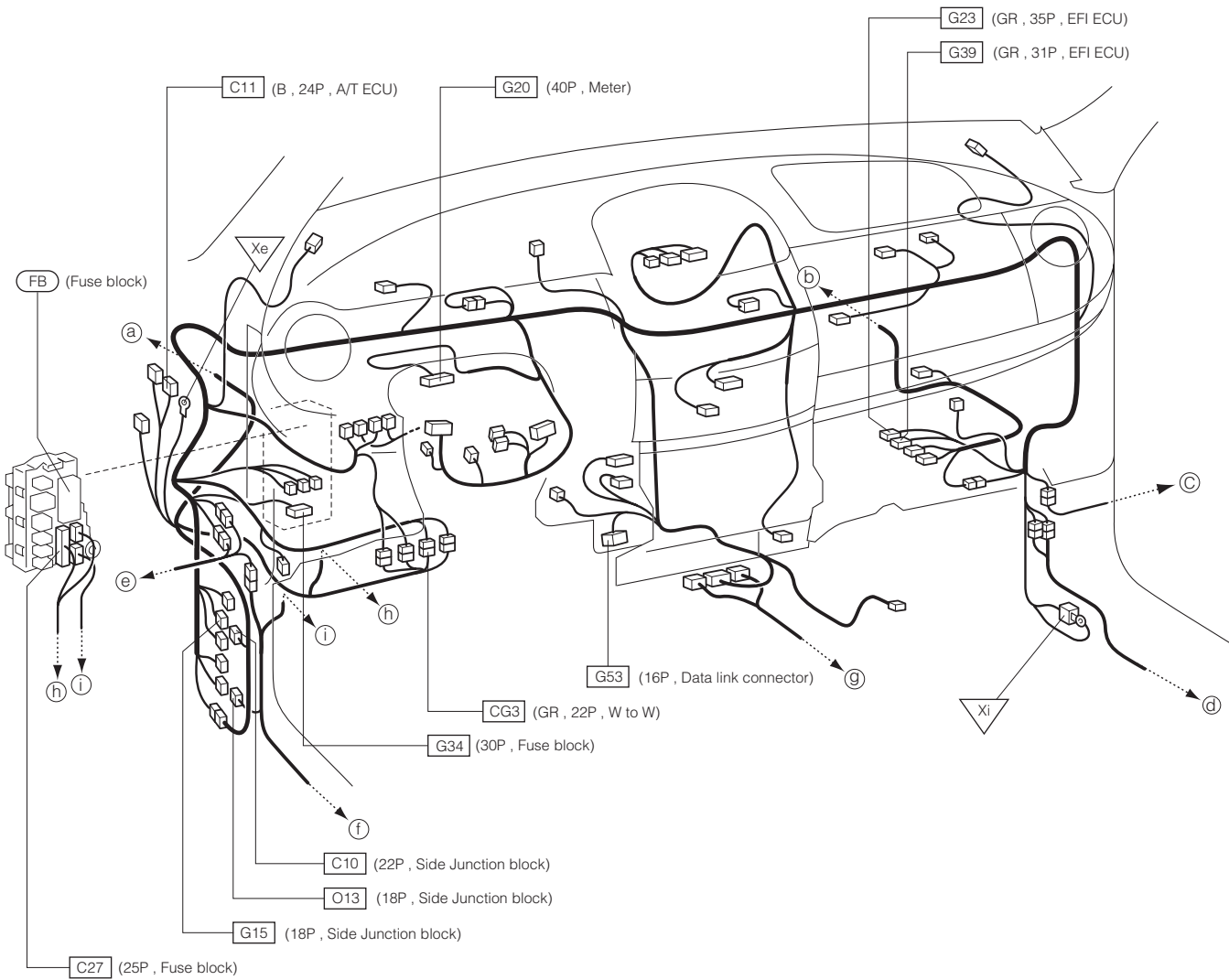

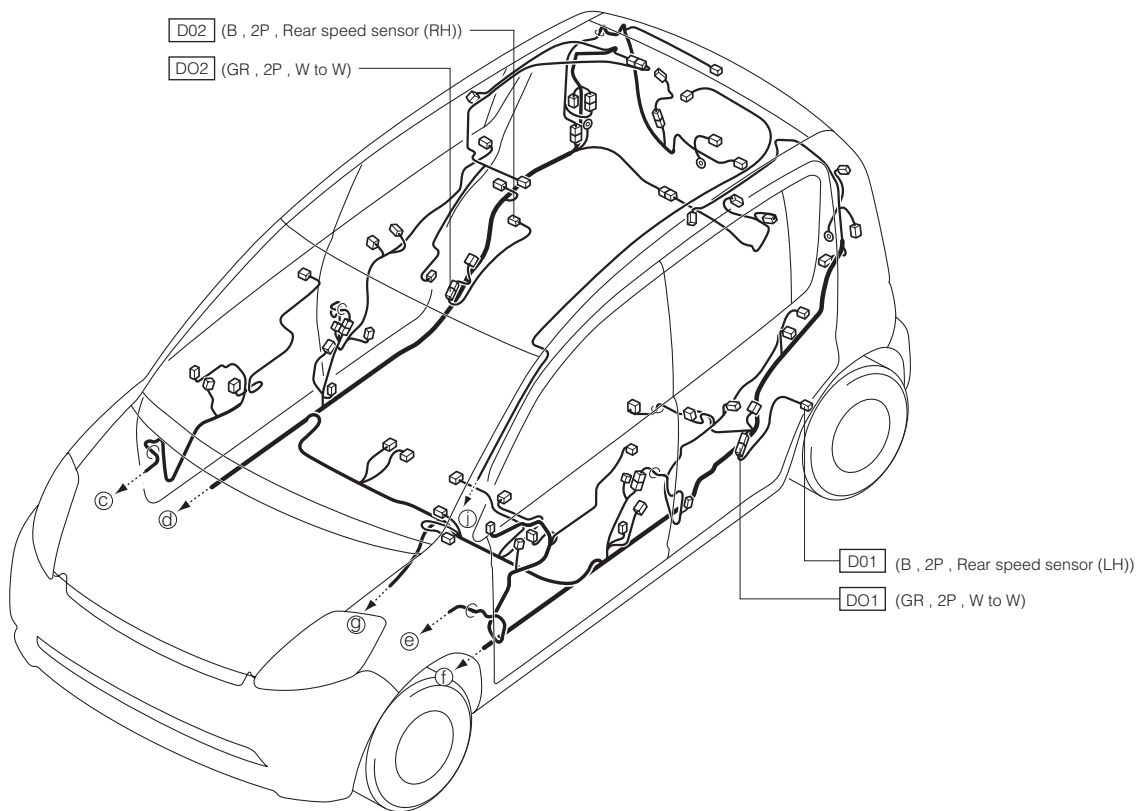
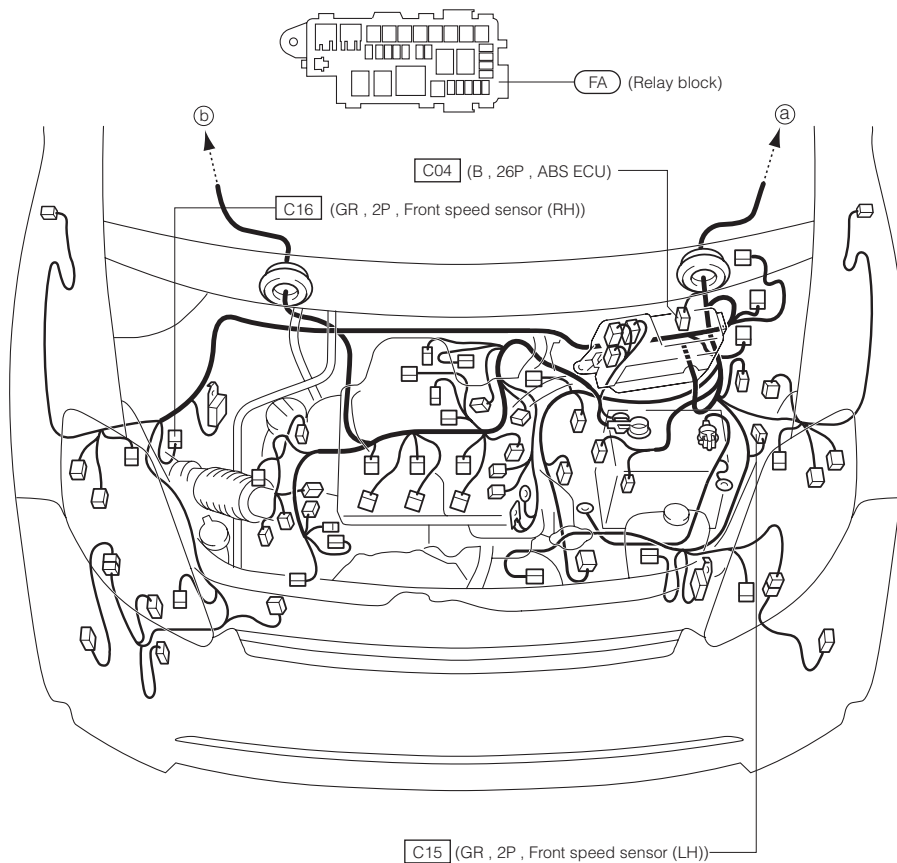

7 A/T CONTROL 7-1 RHD VEHICLE

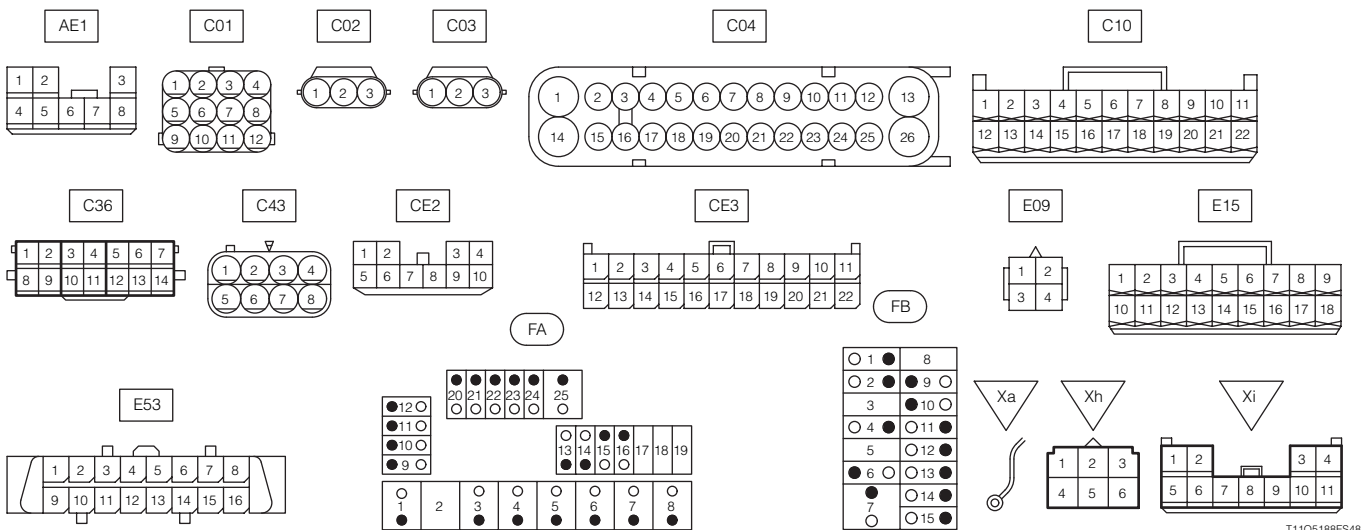
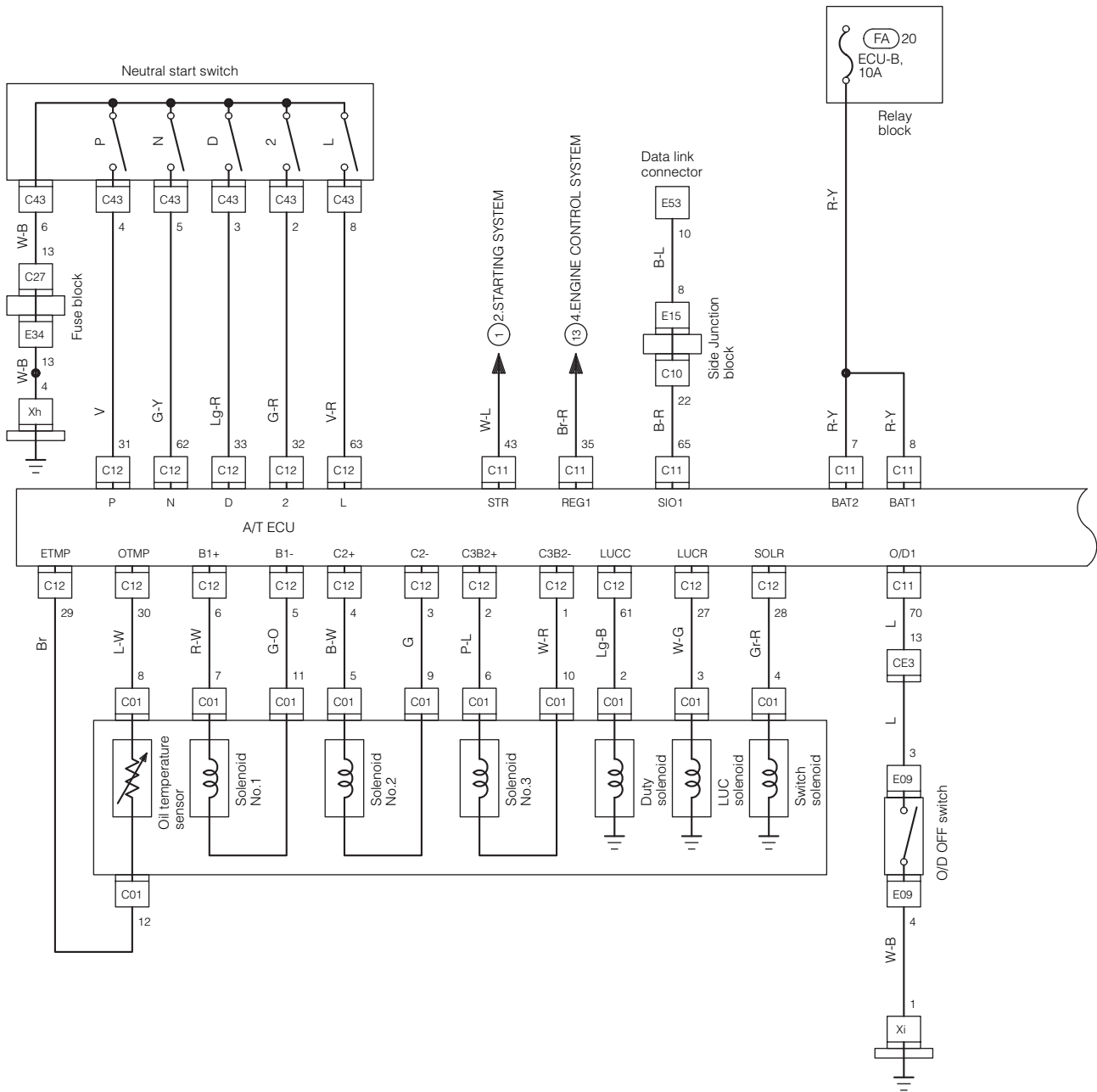

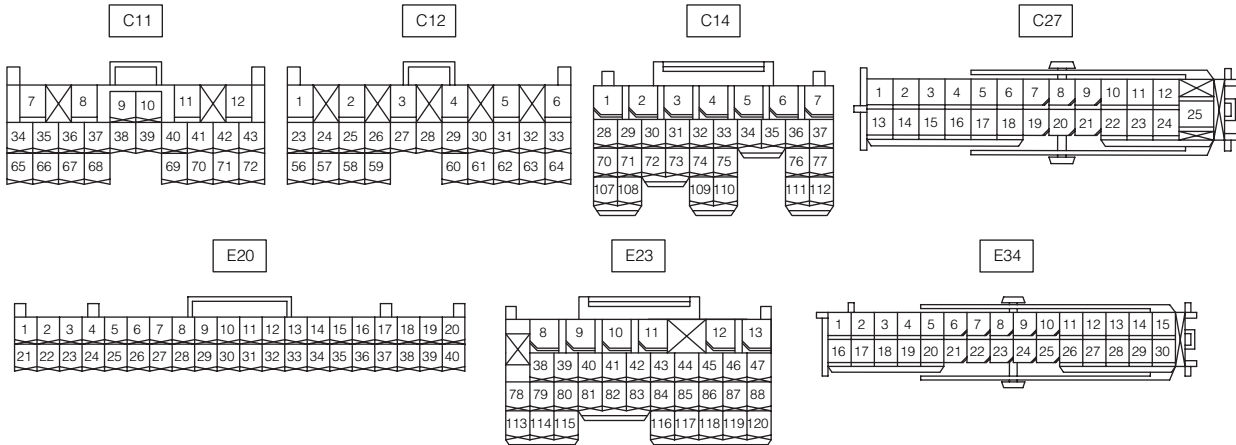
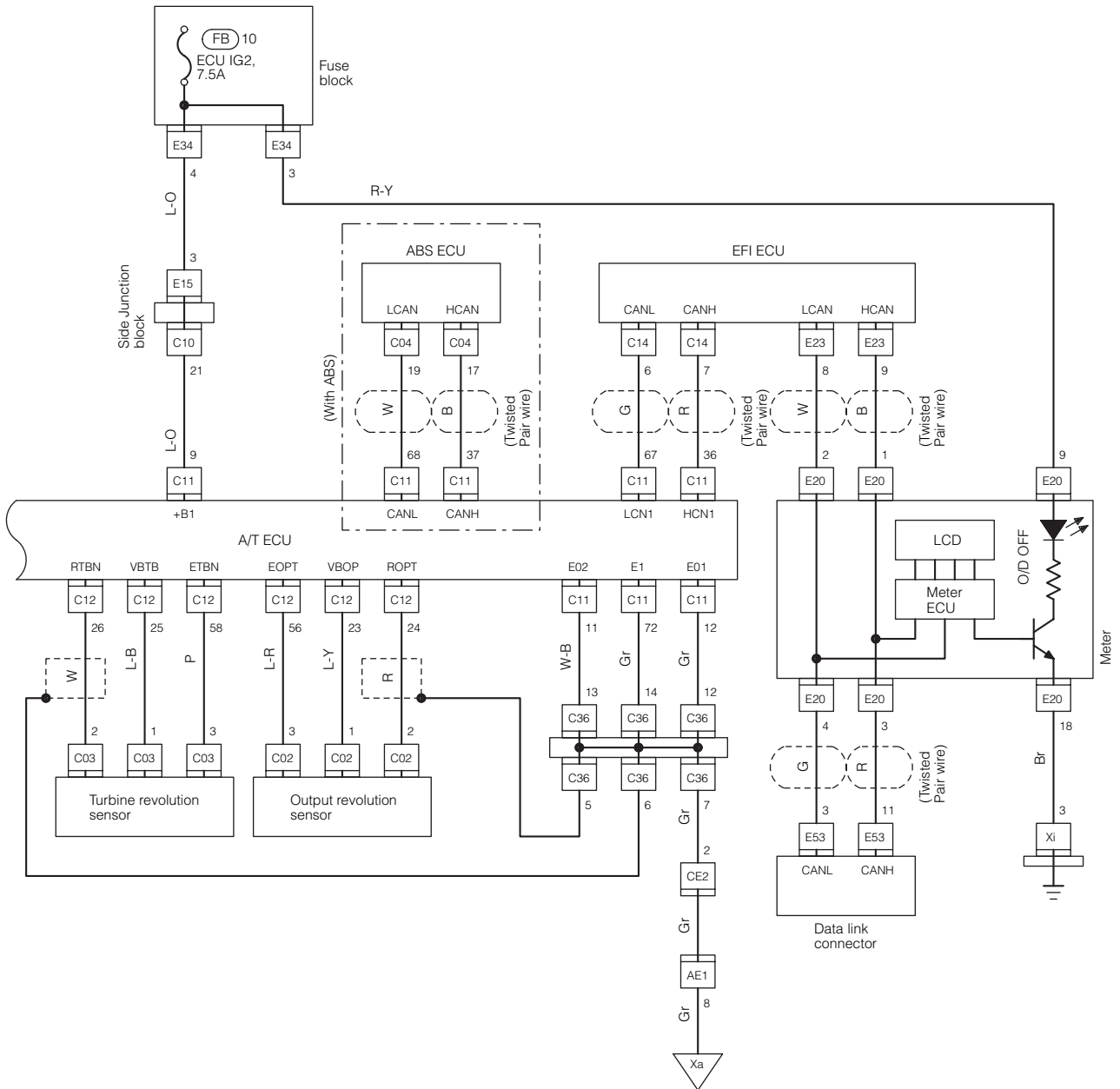

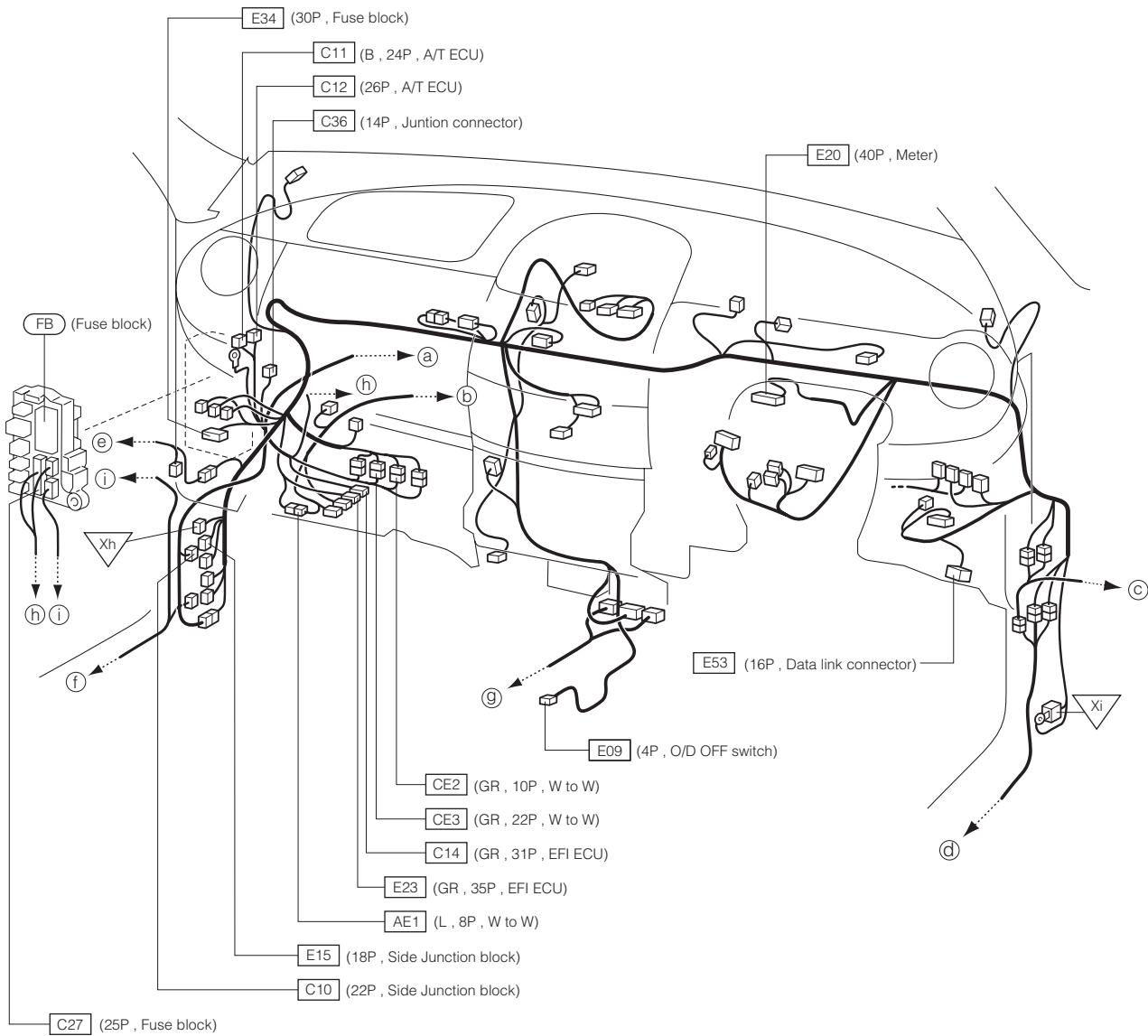

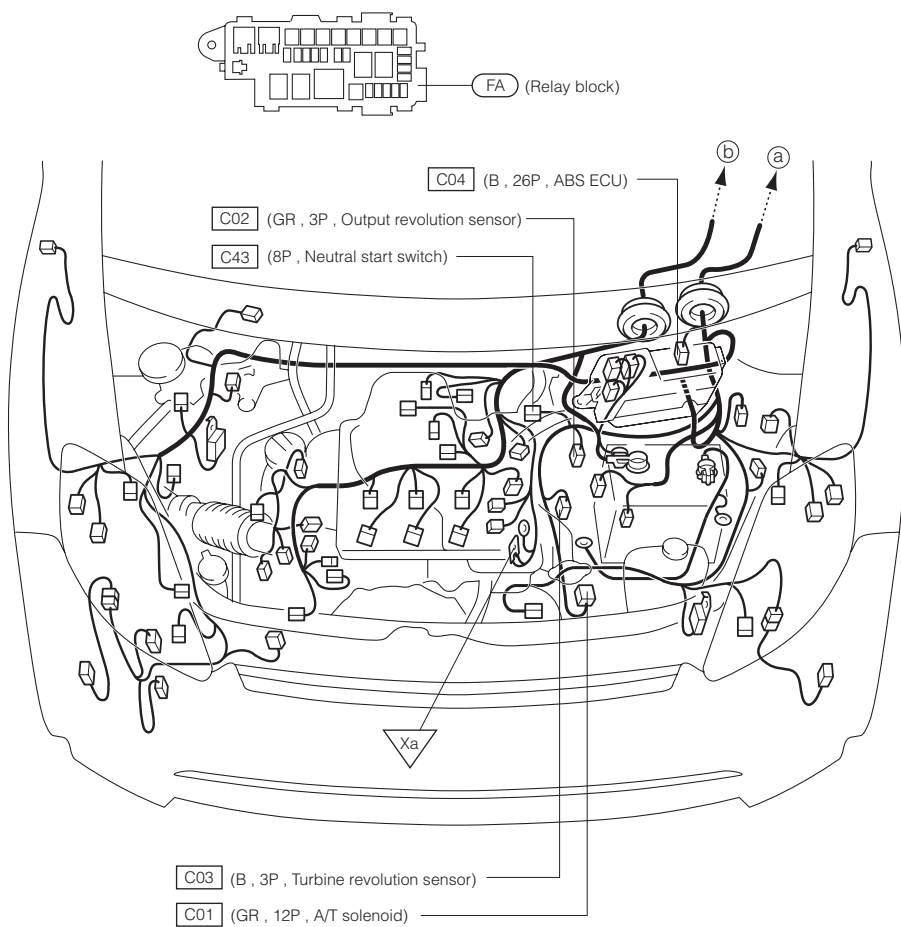

7-2 LHD VEHICLE

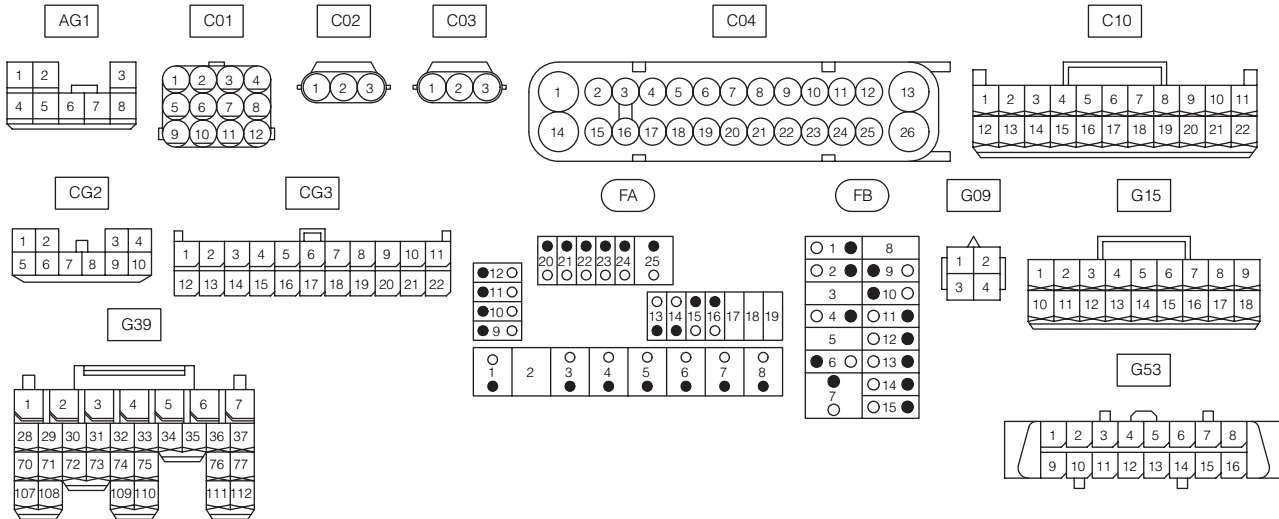
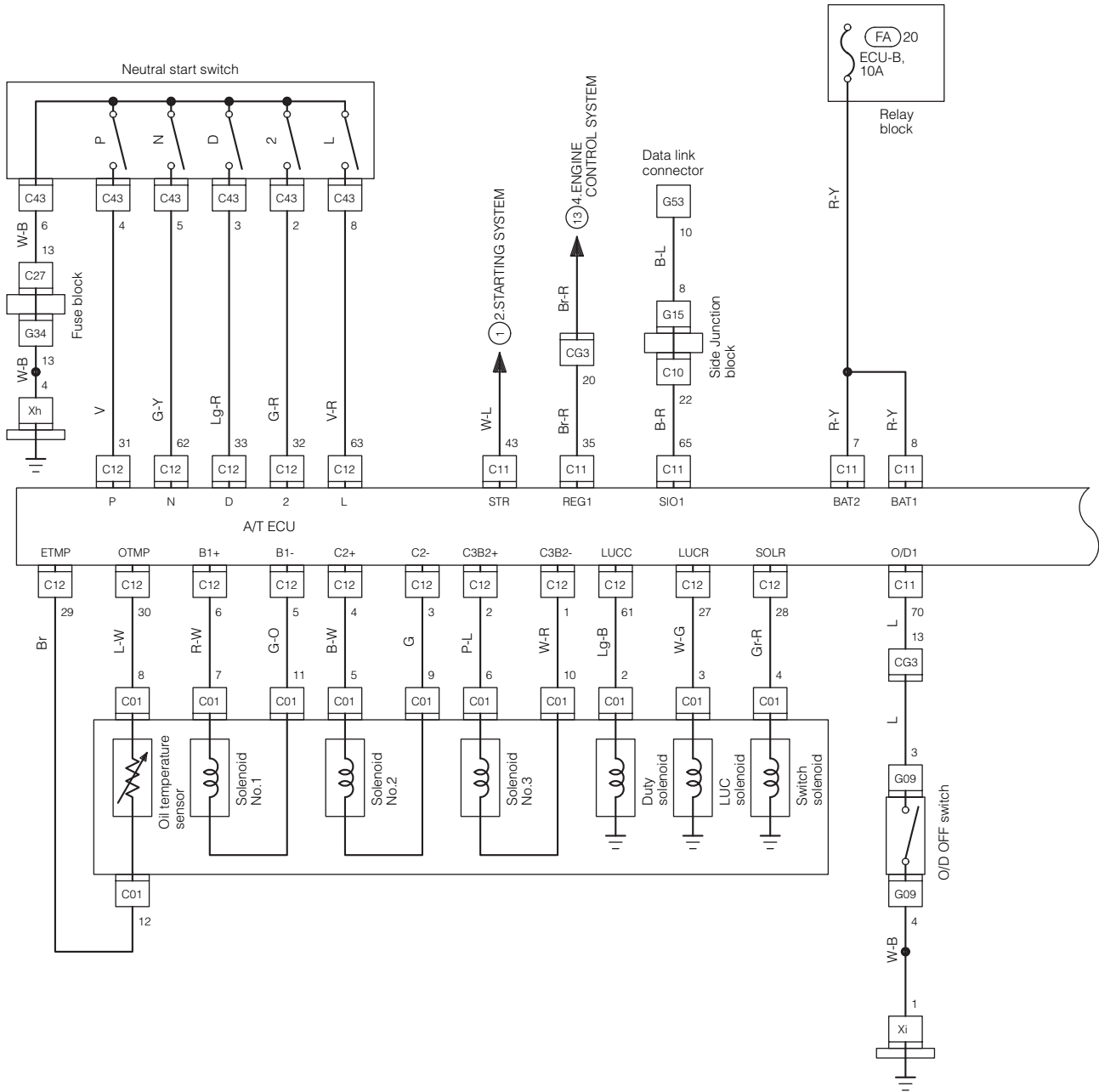

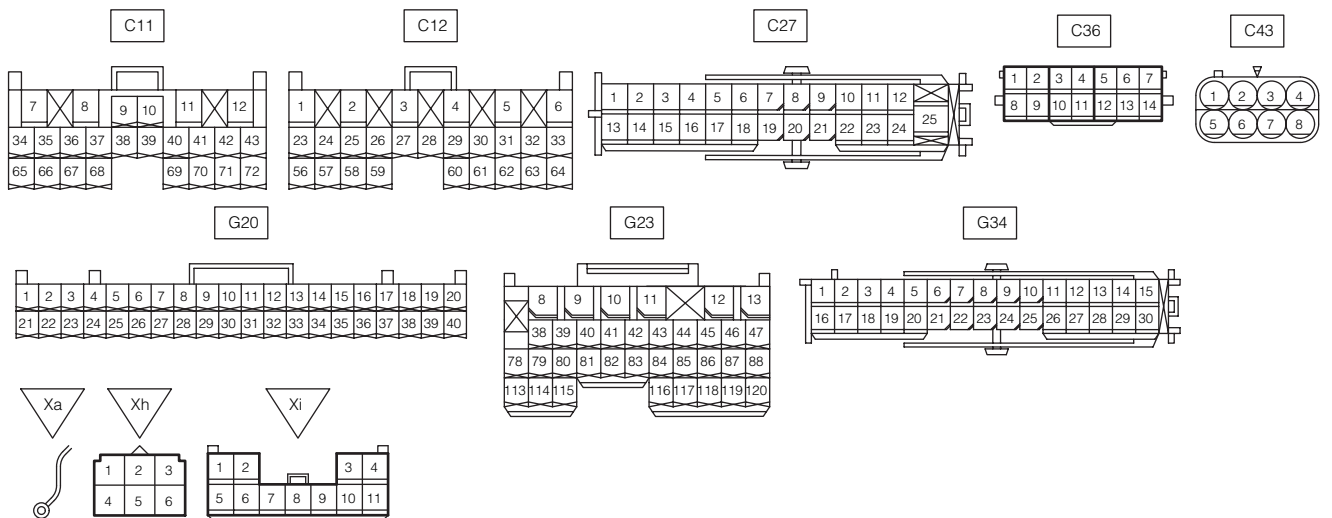
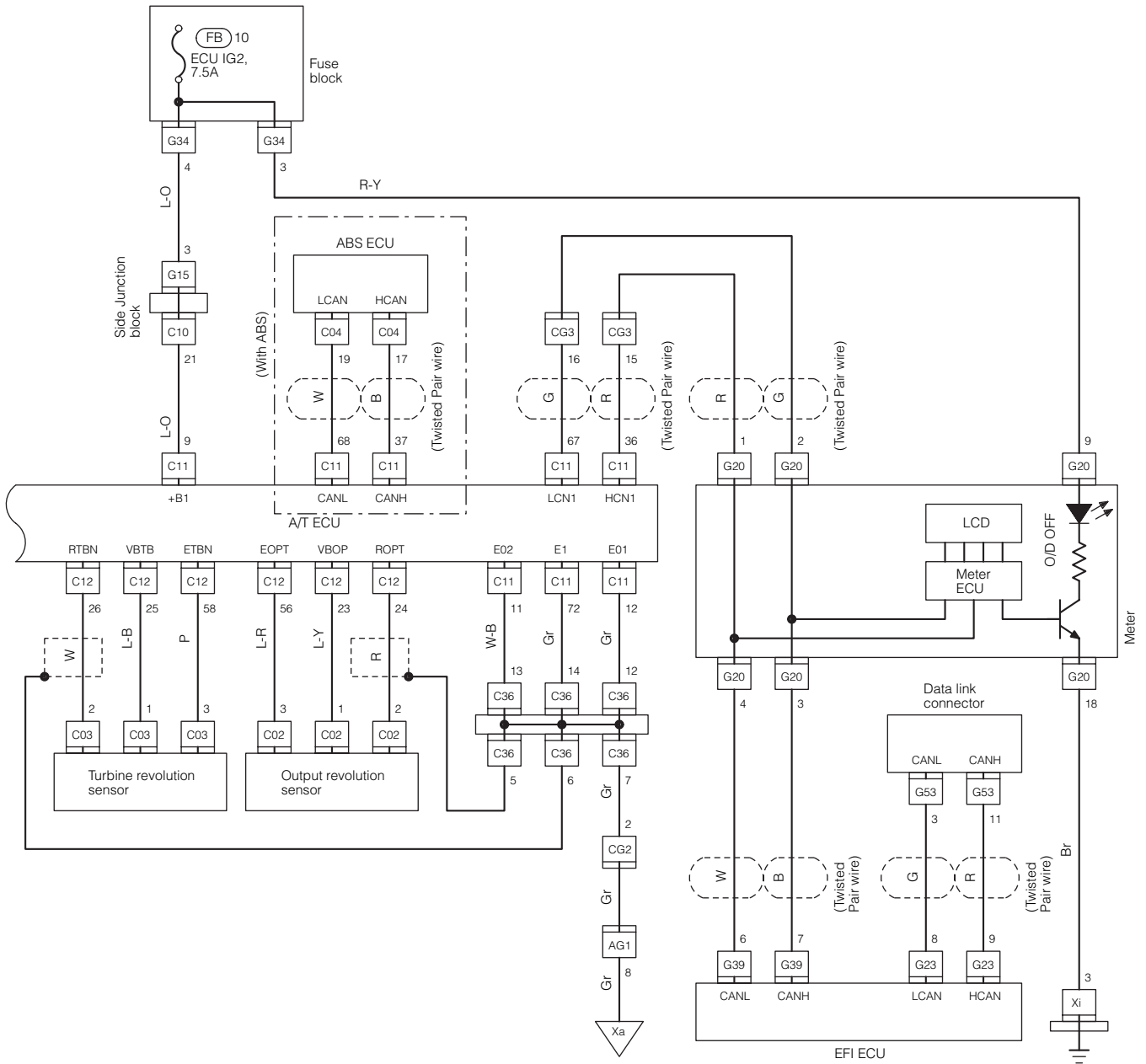

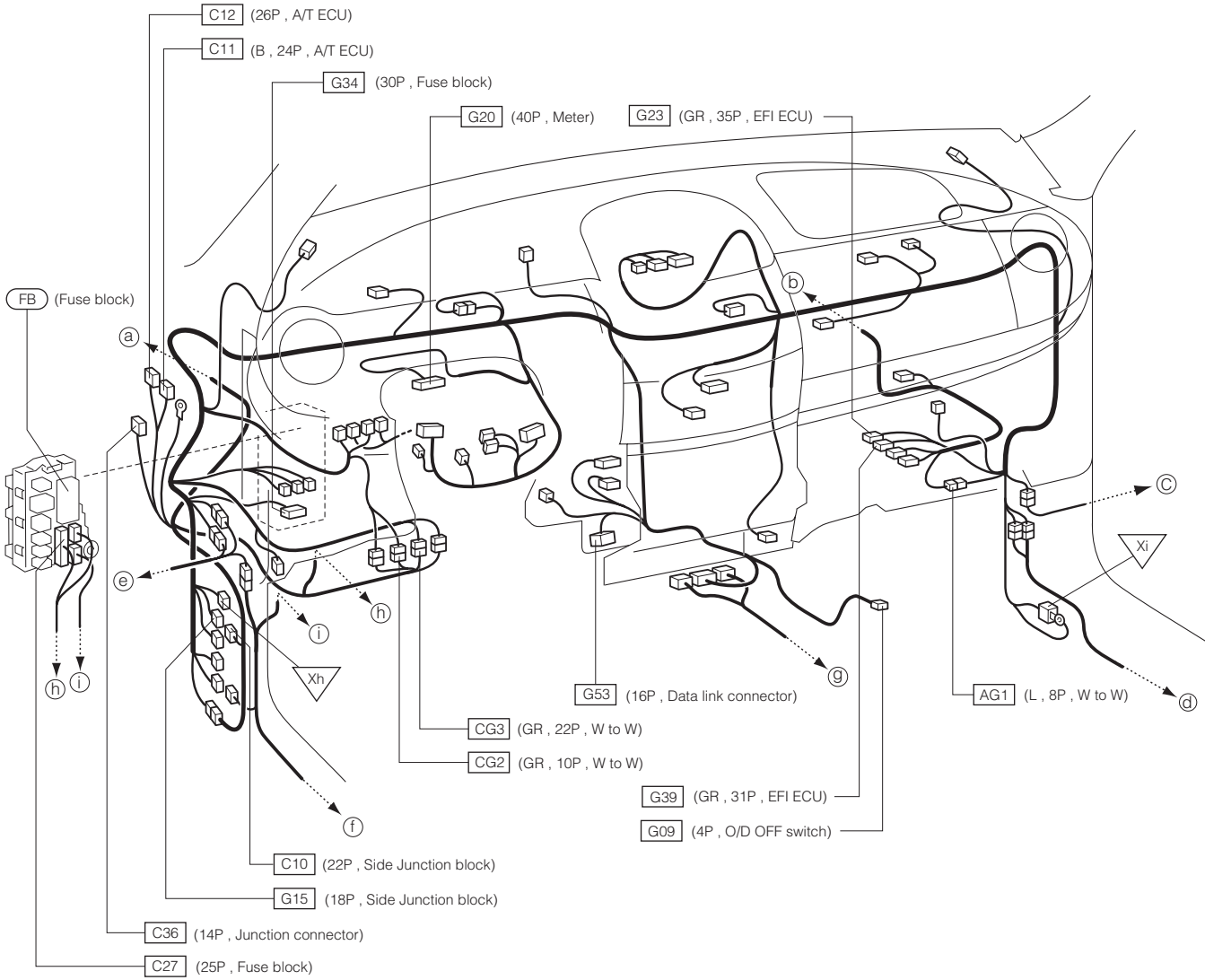

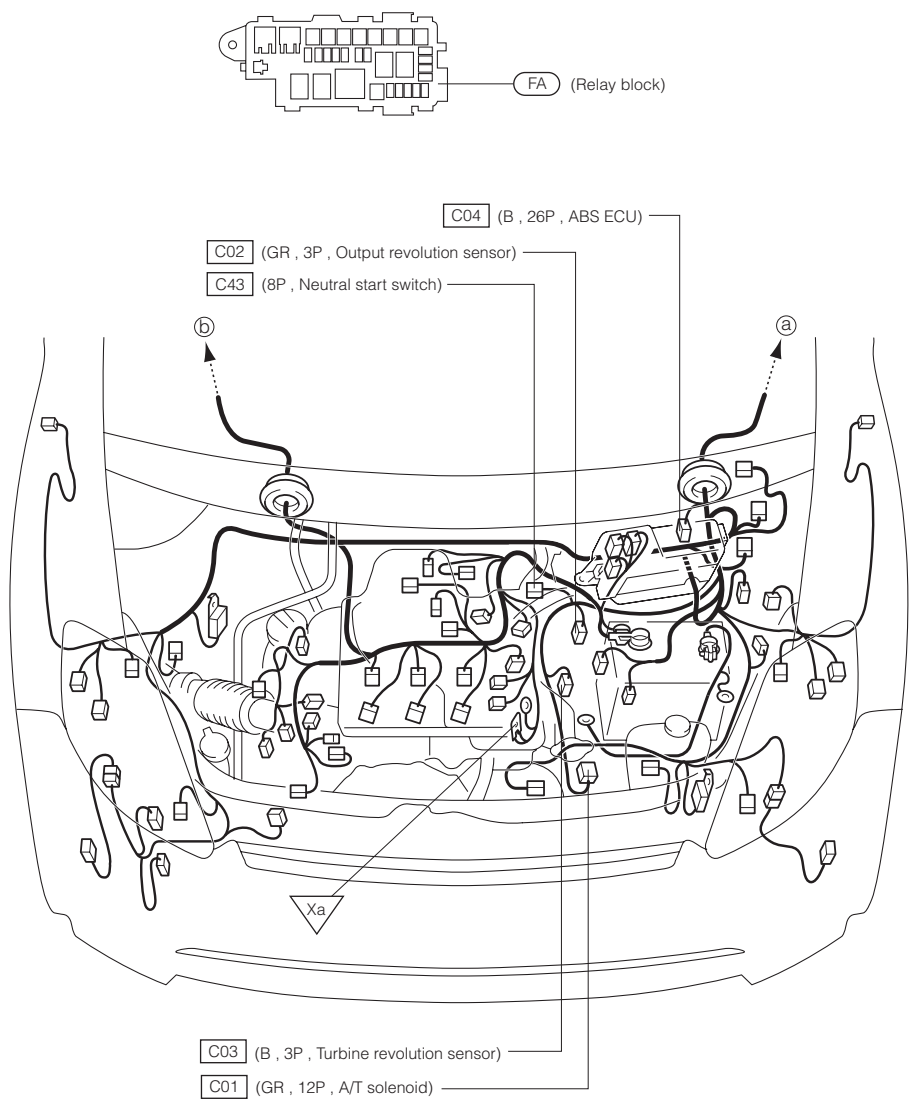

8 ELECTRIC POWER STEERING 8-1 RHD VEHICLE

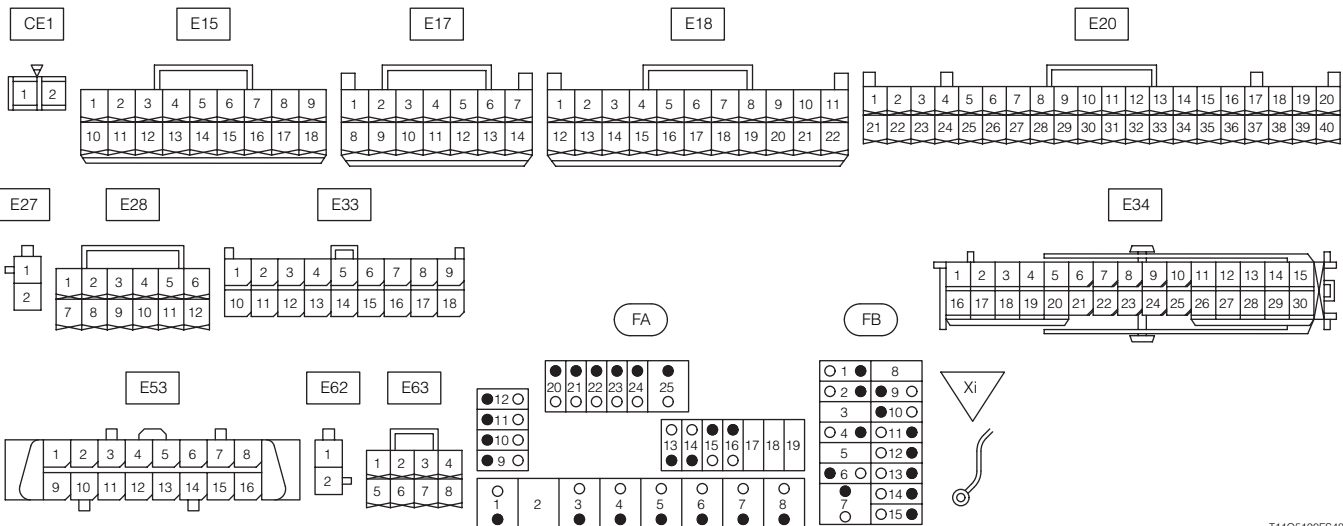
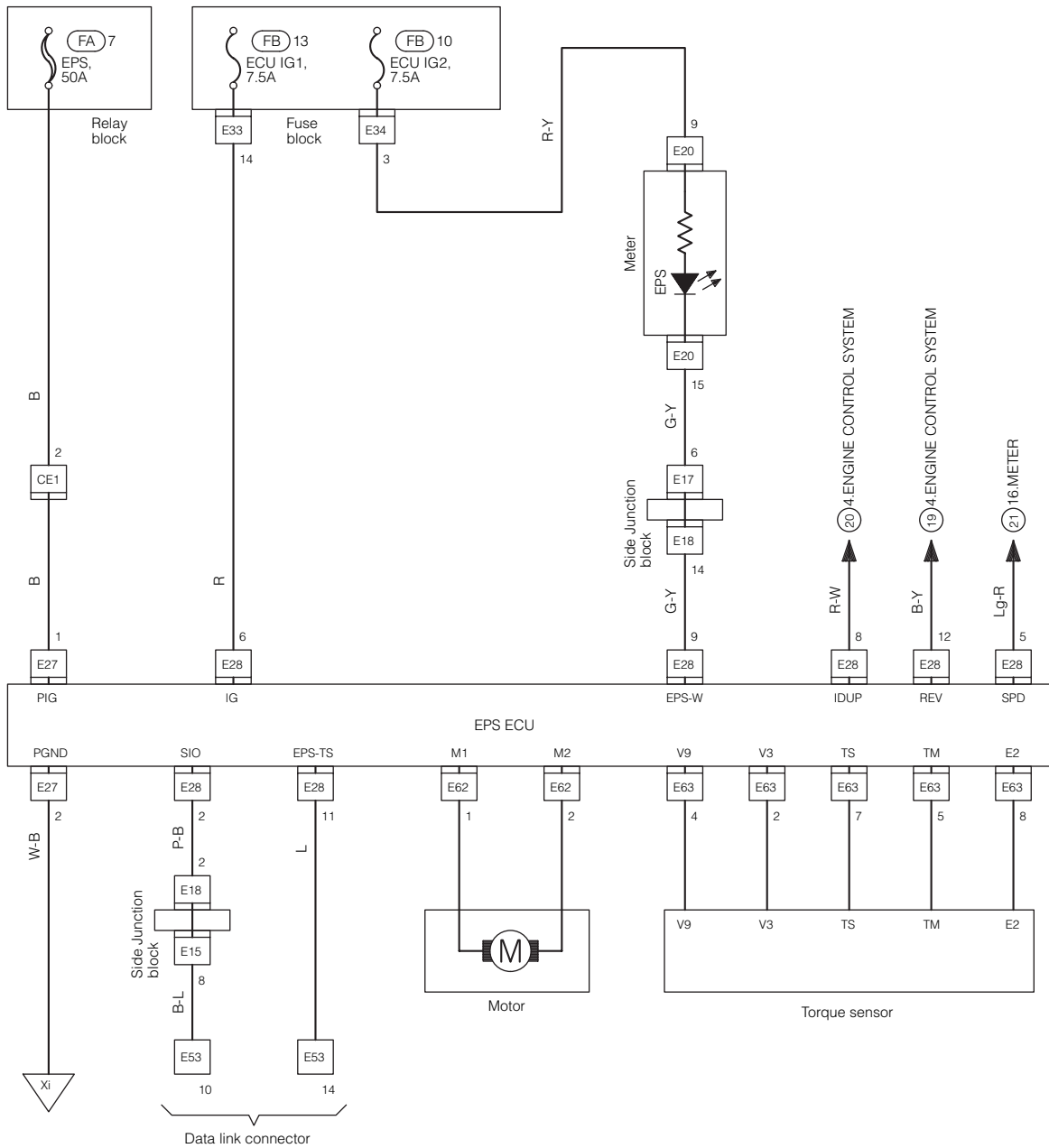

(MEMO)

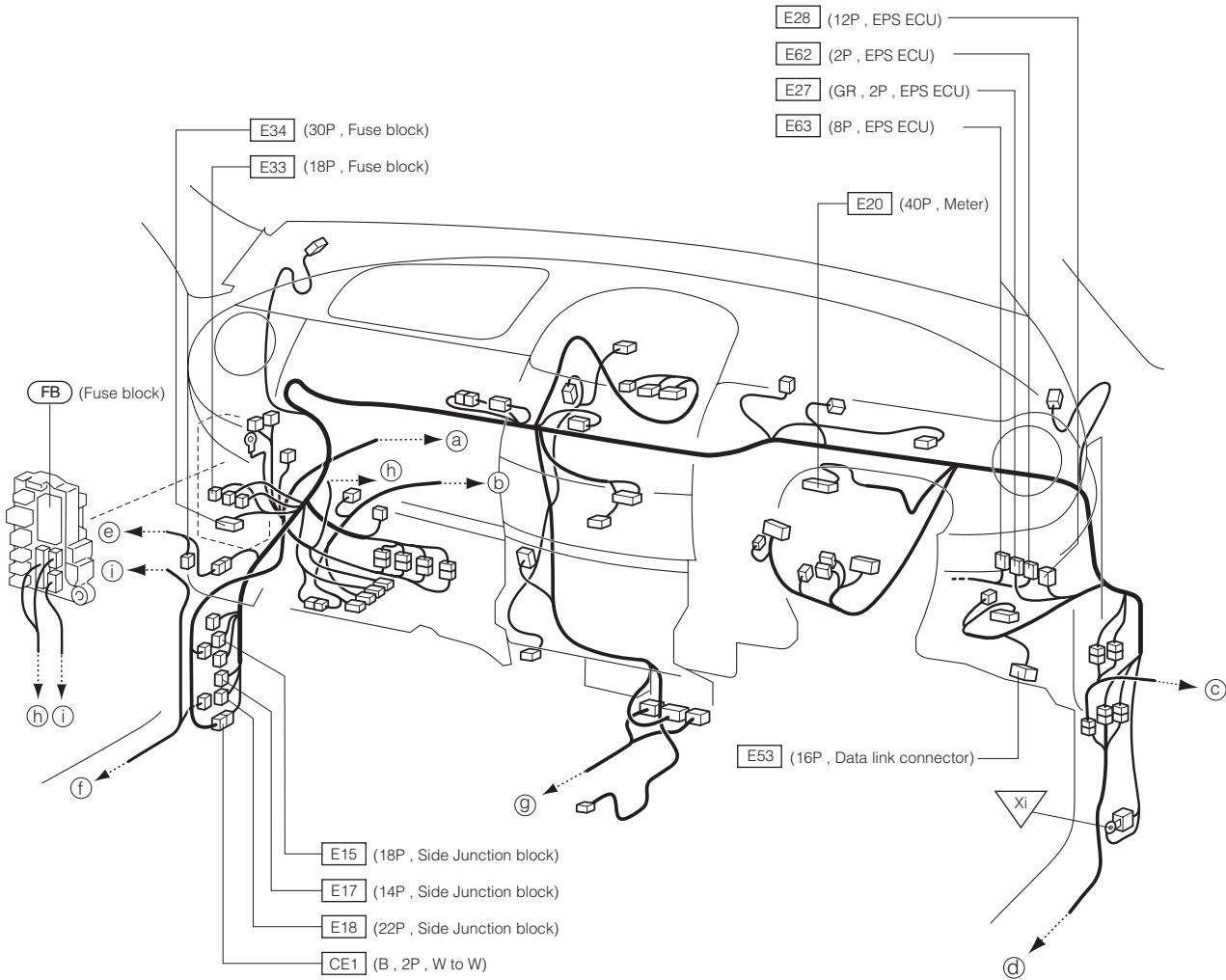

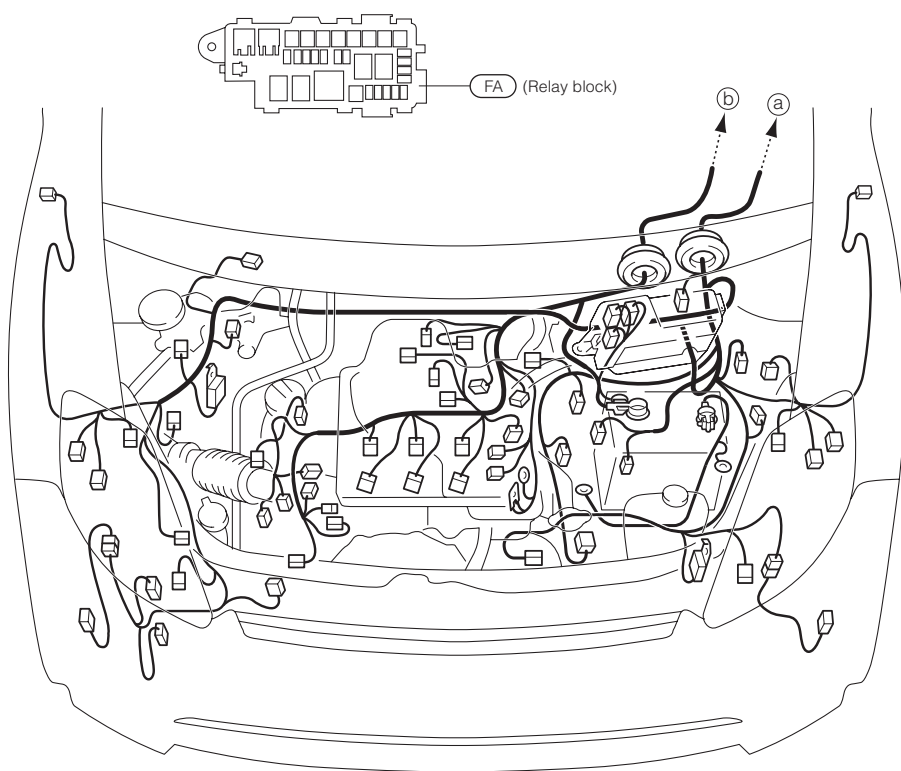

8-2 LHD VEHICLE

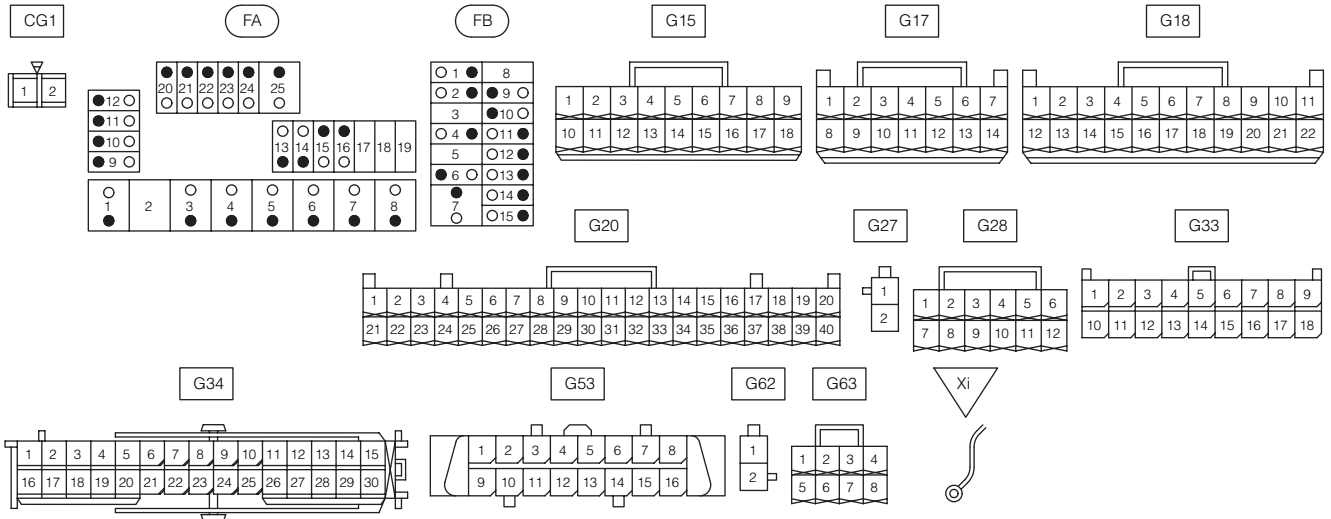
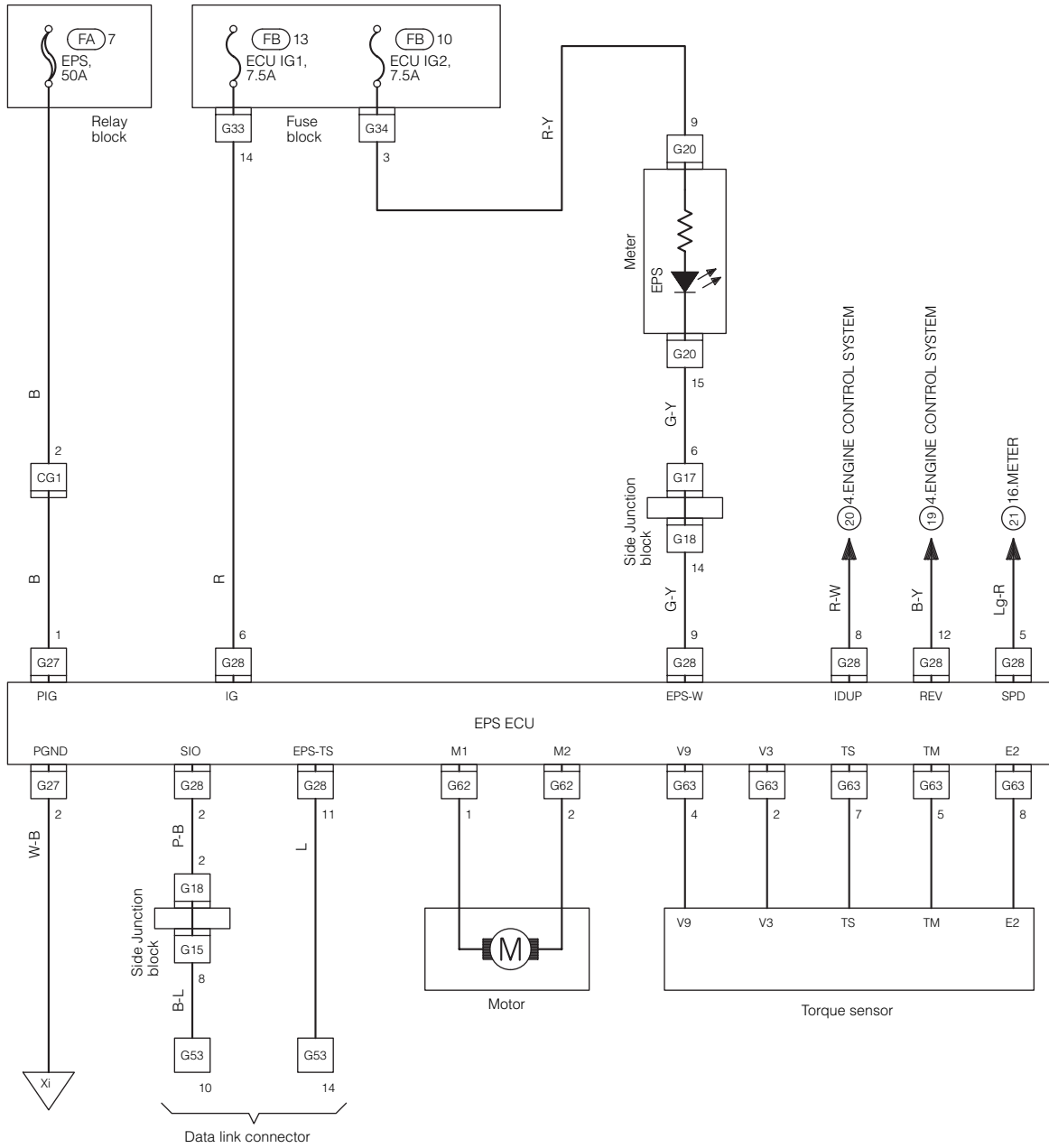

(MEMO)

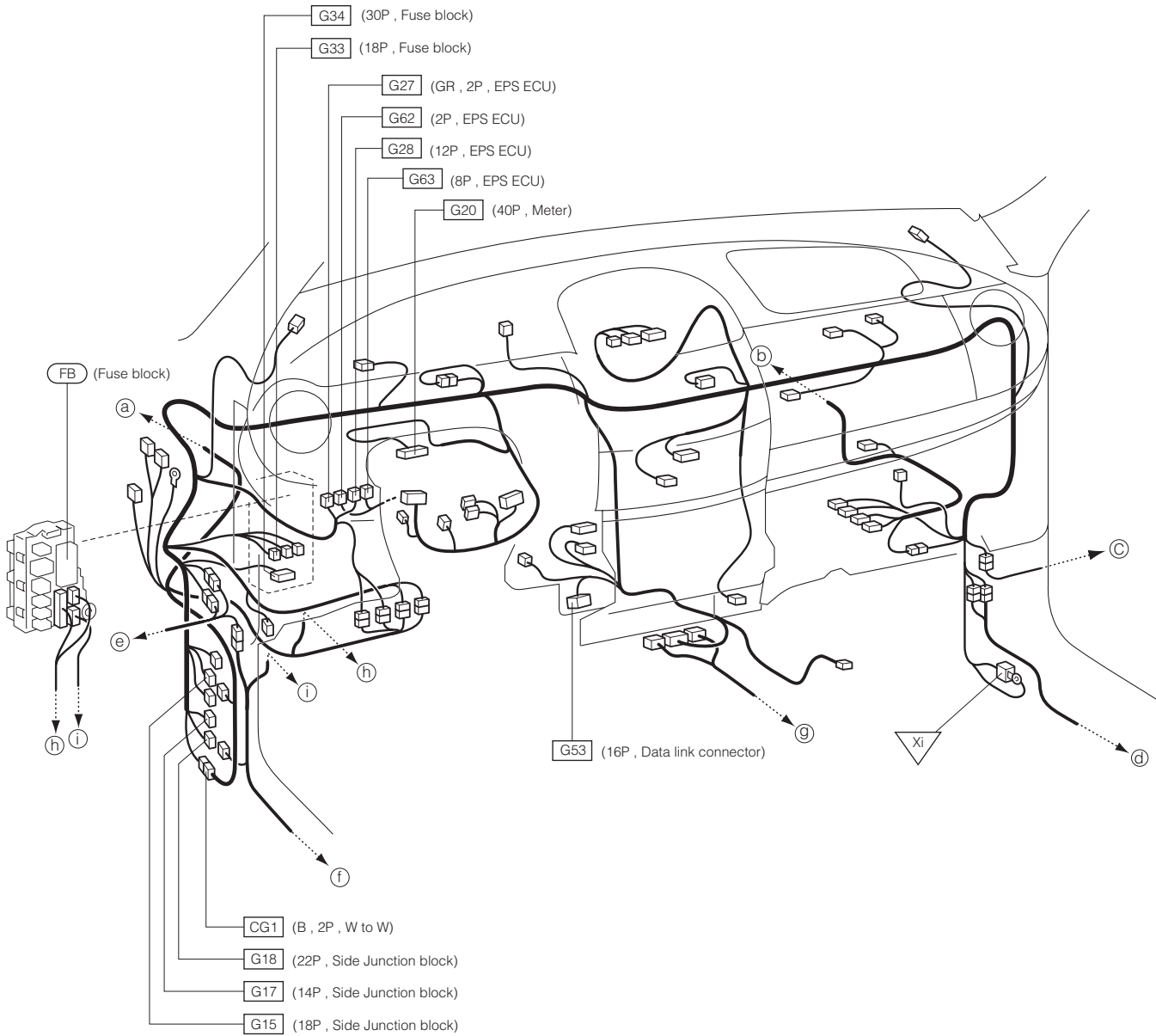

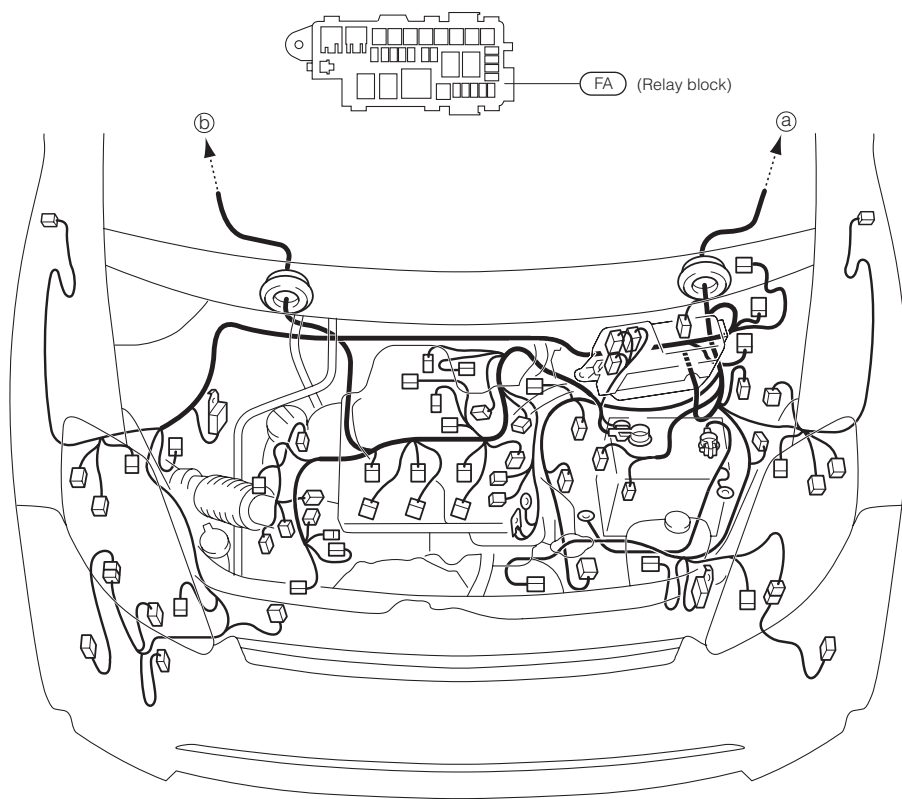

9 SRS AIRBAG SYSTEM 9-1 RHD VEHICLE

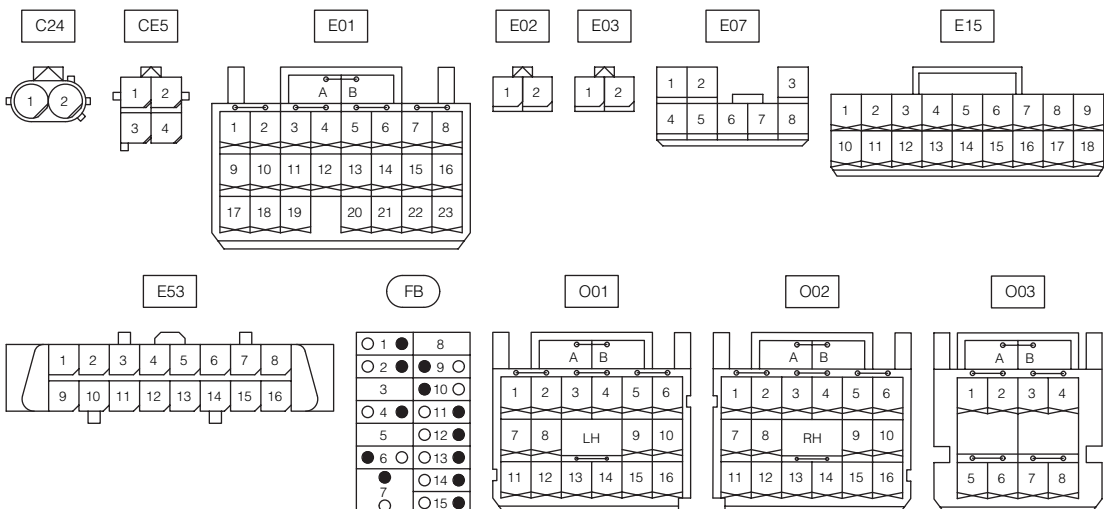
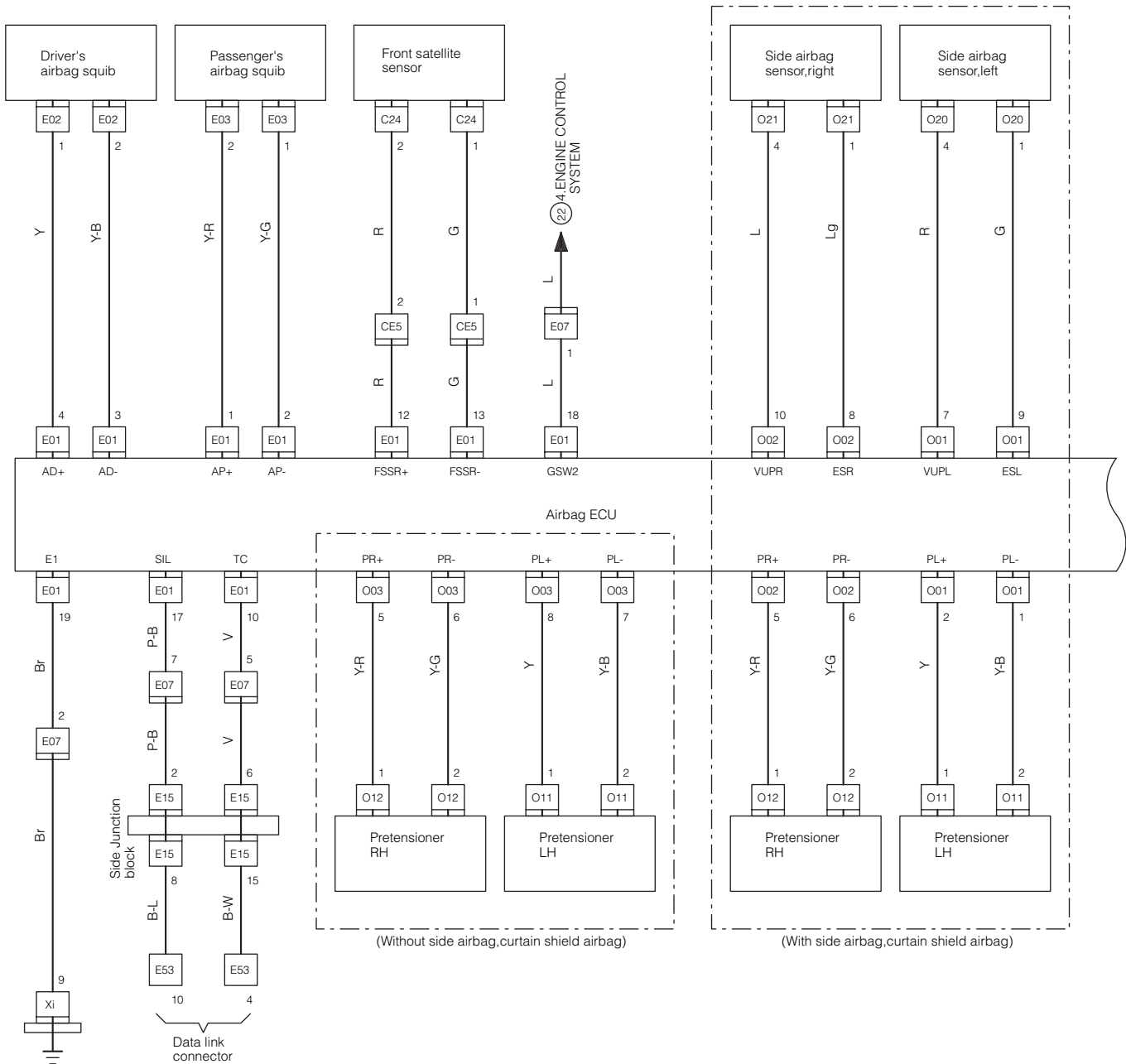

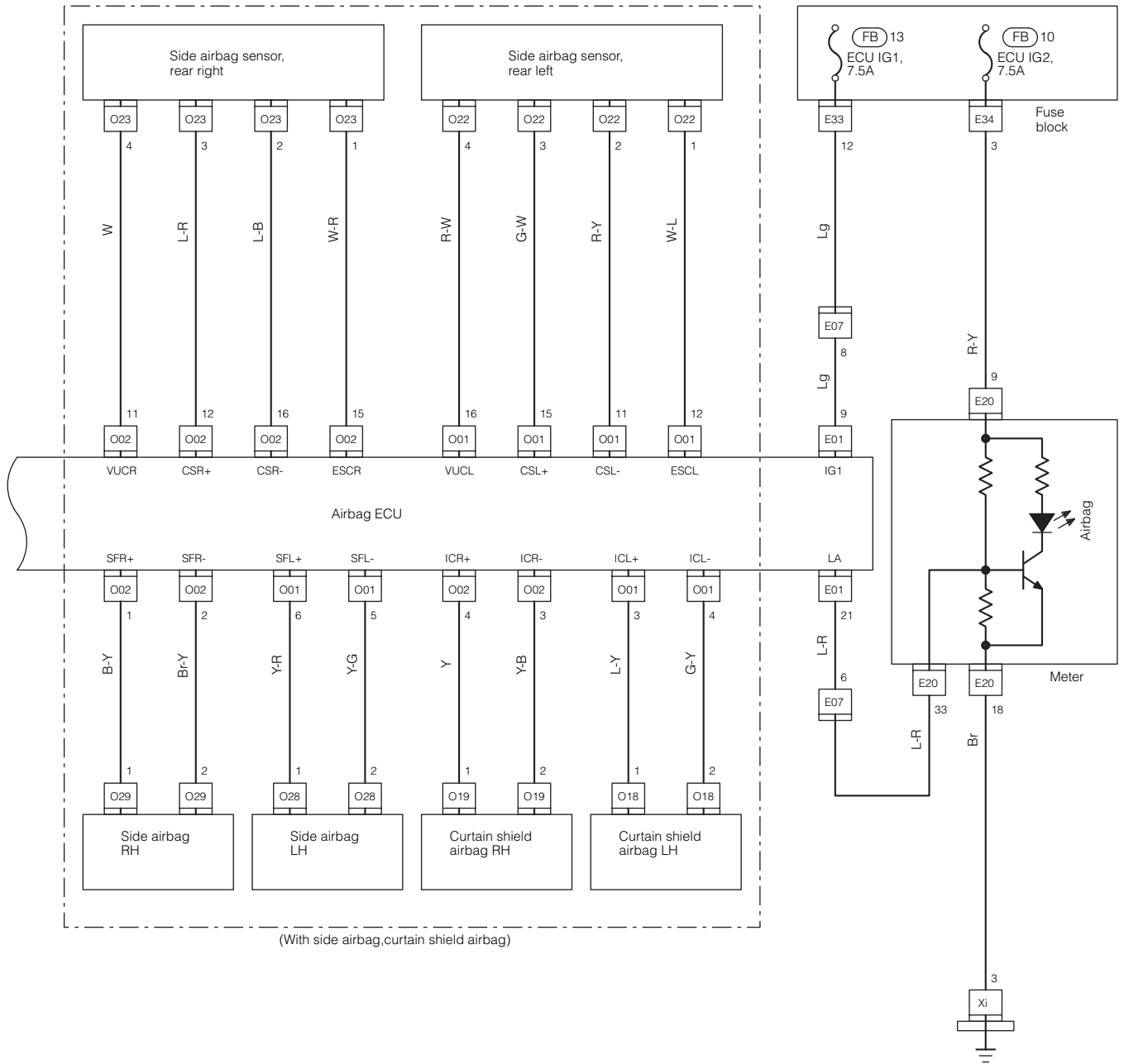

(With side airbag,curtain shield airbag)

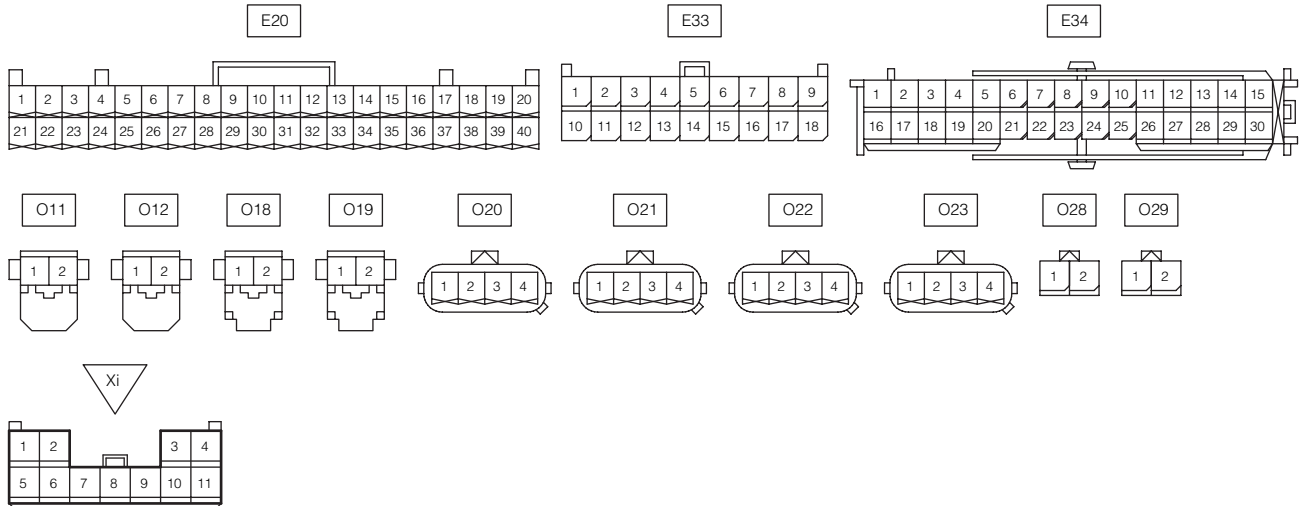

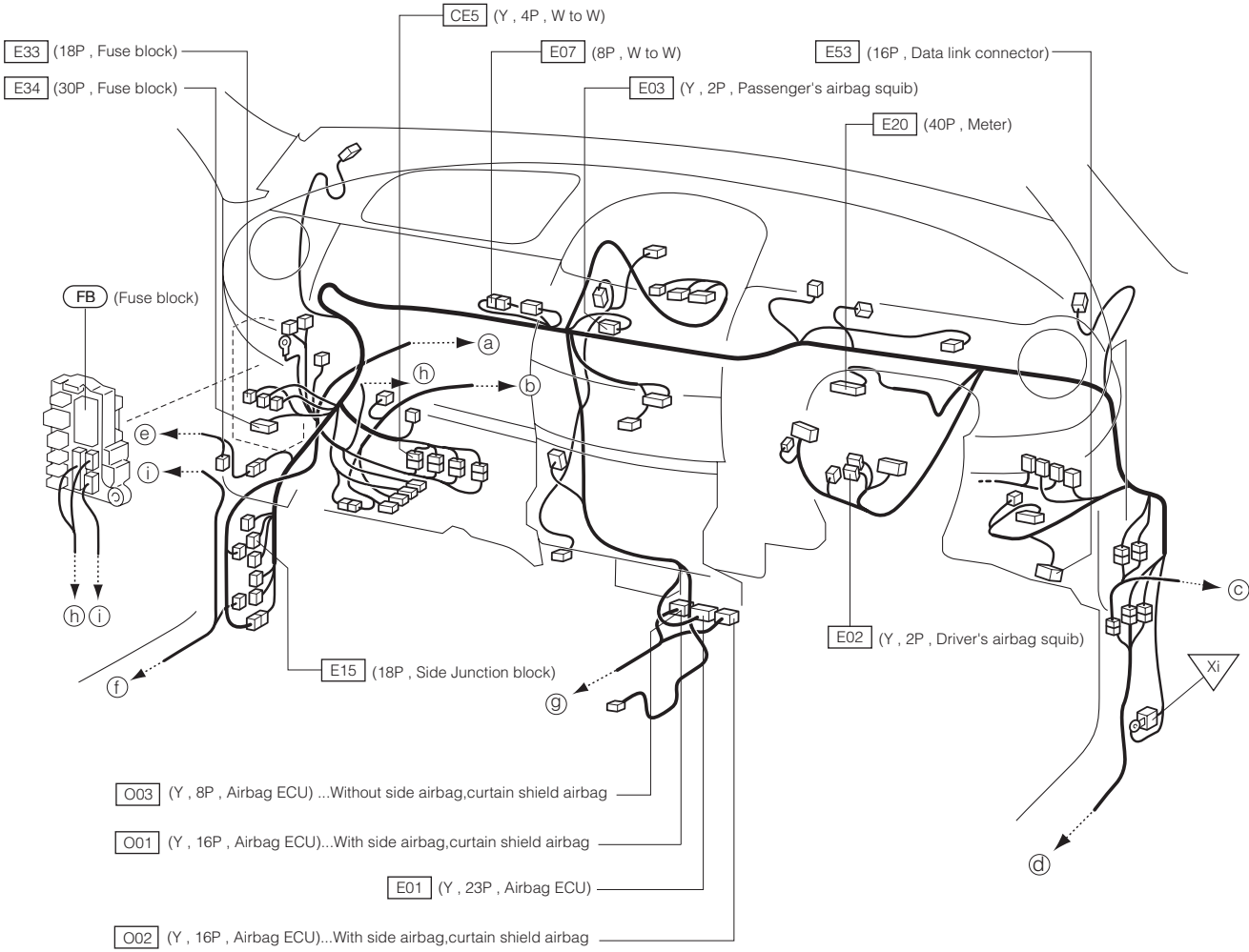

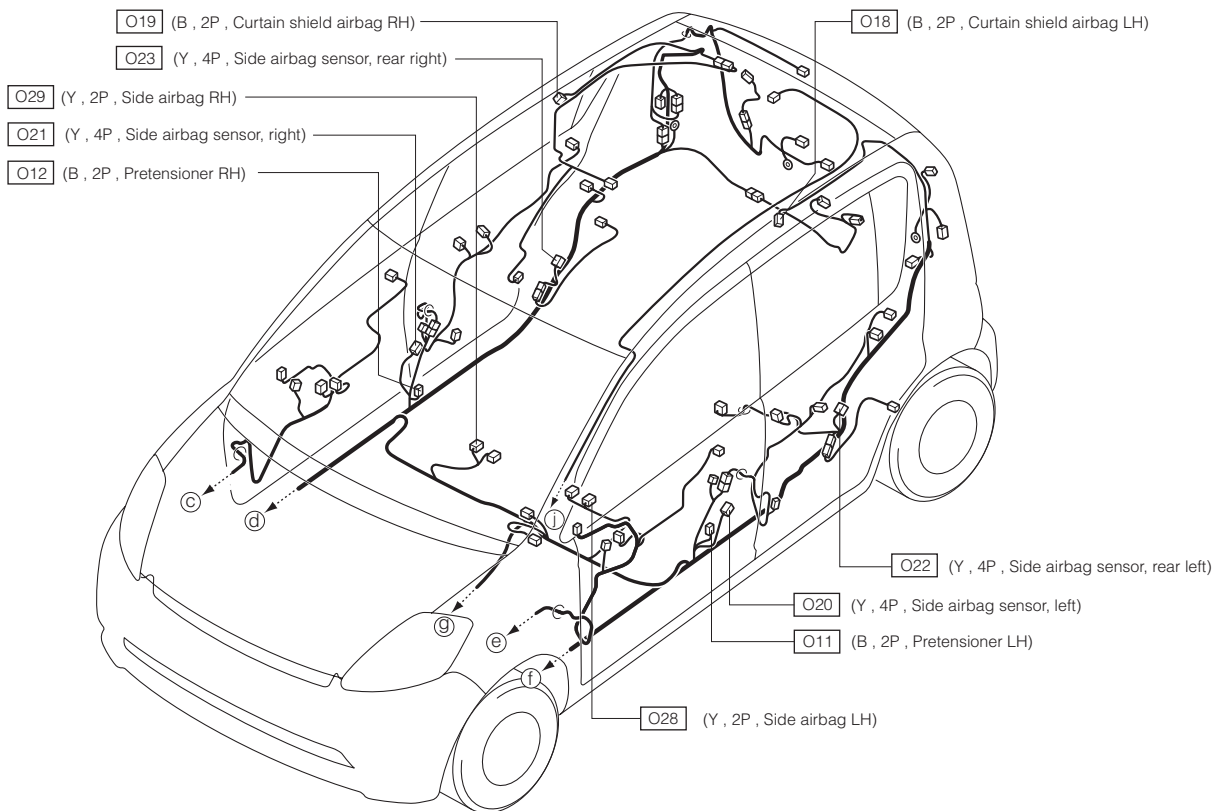
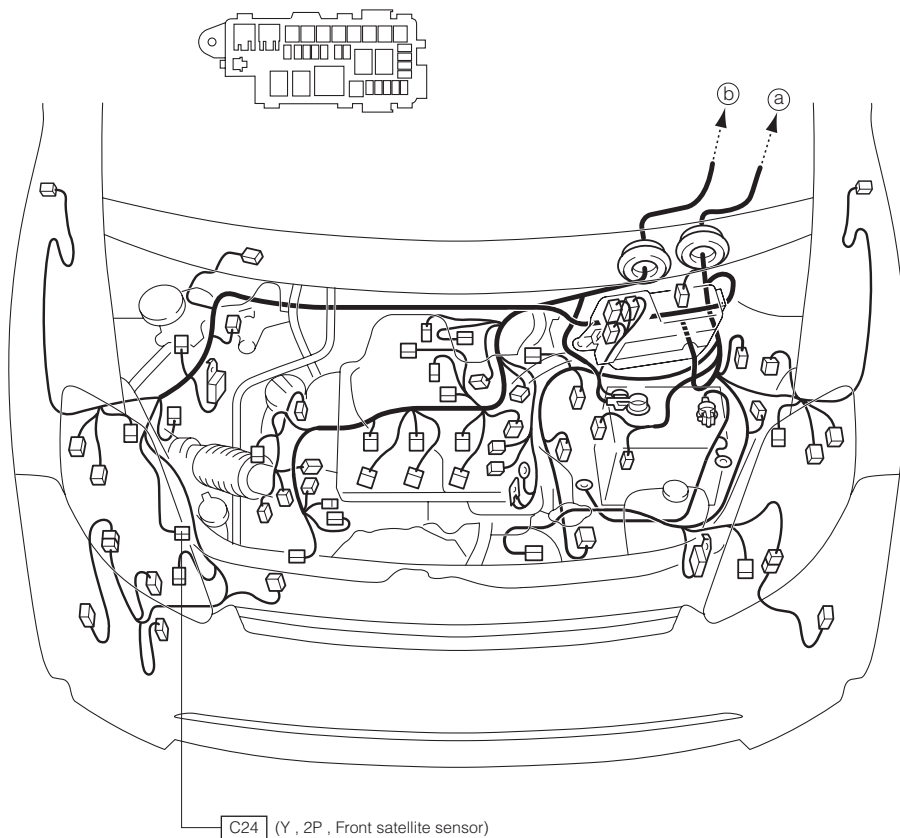

9-2 LHD VEHICLE

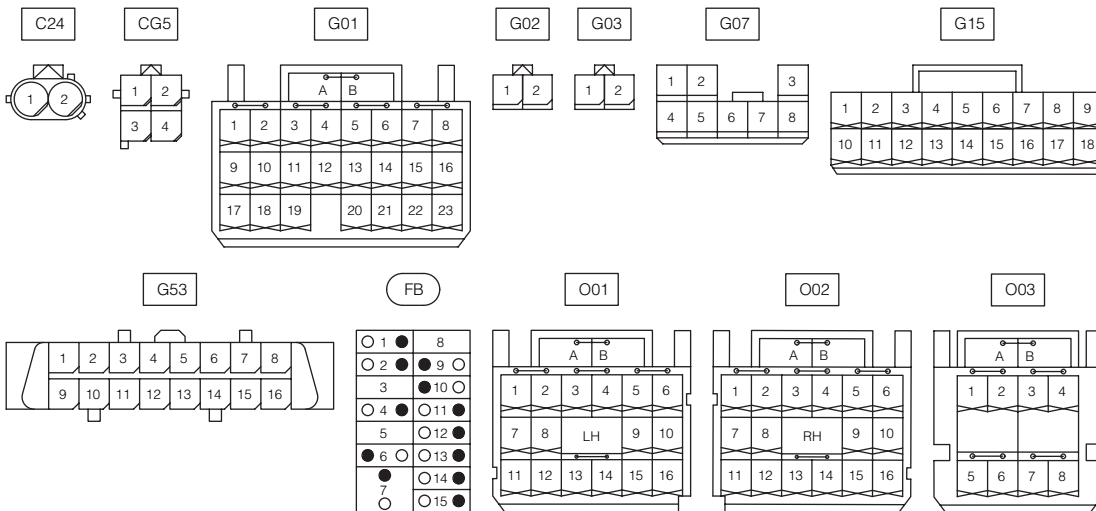
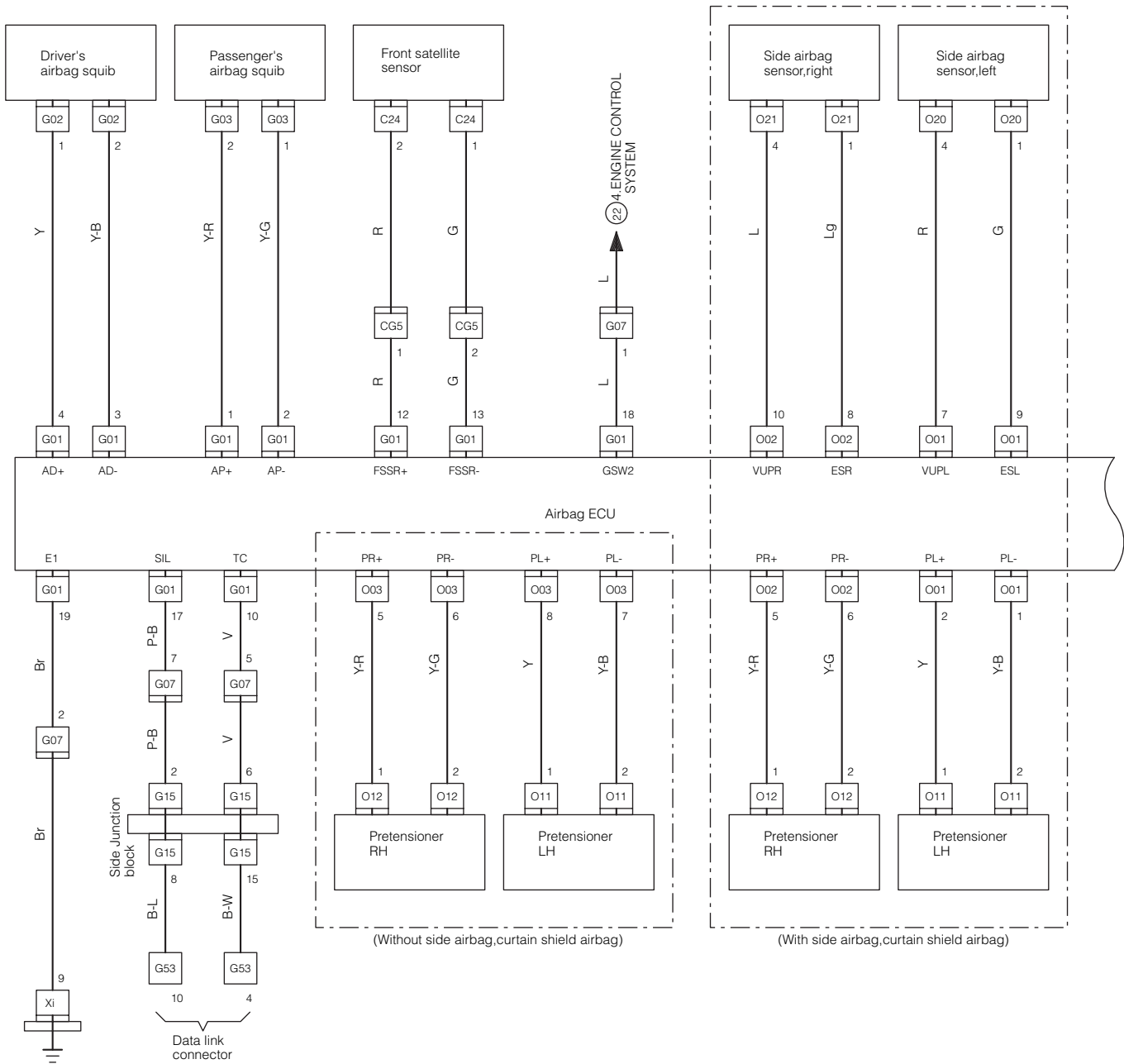

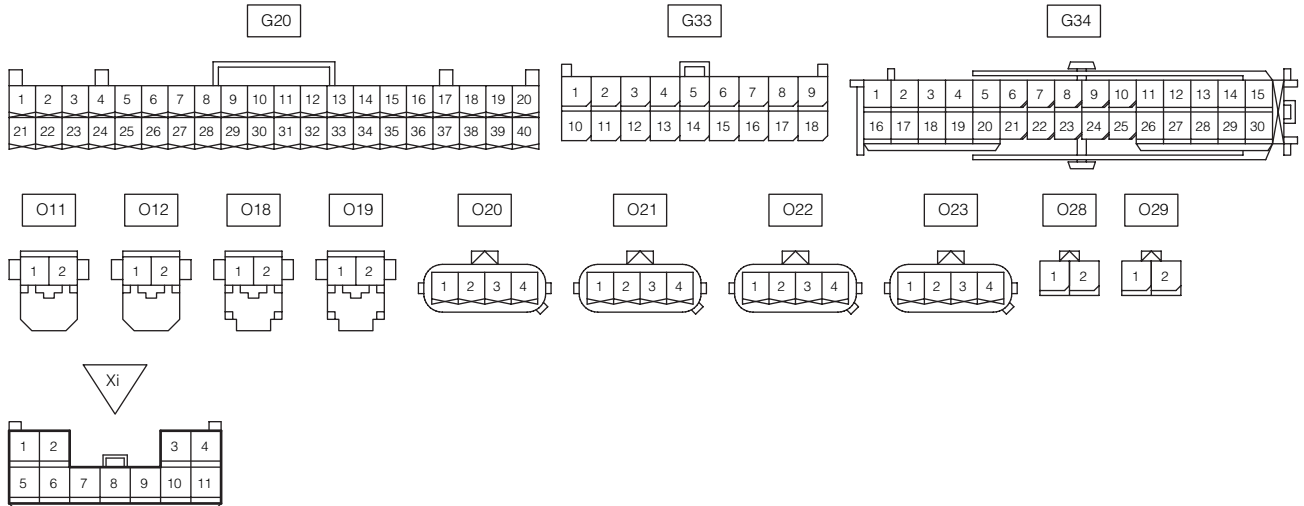
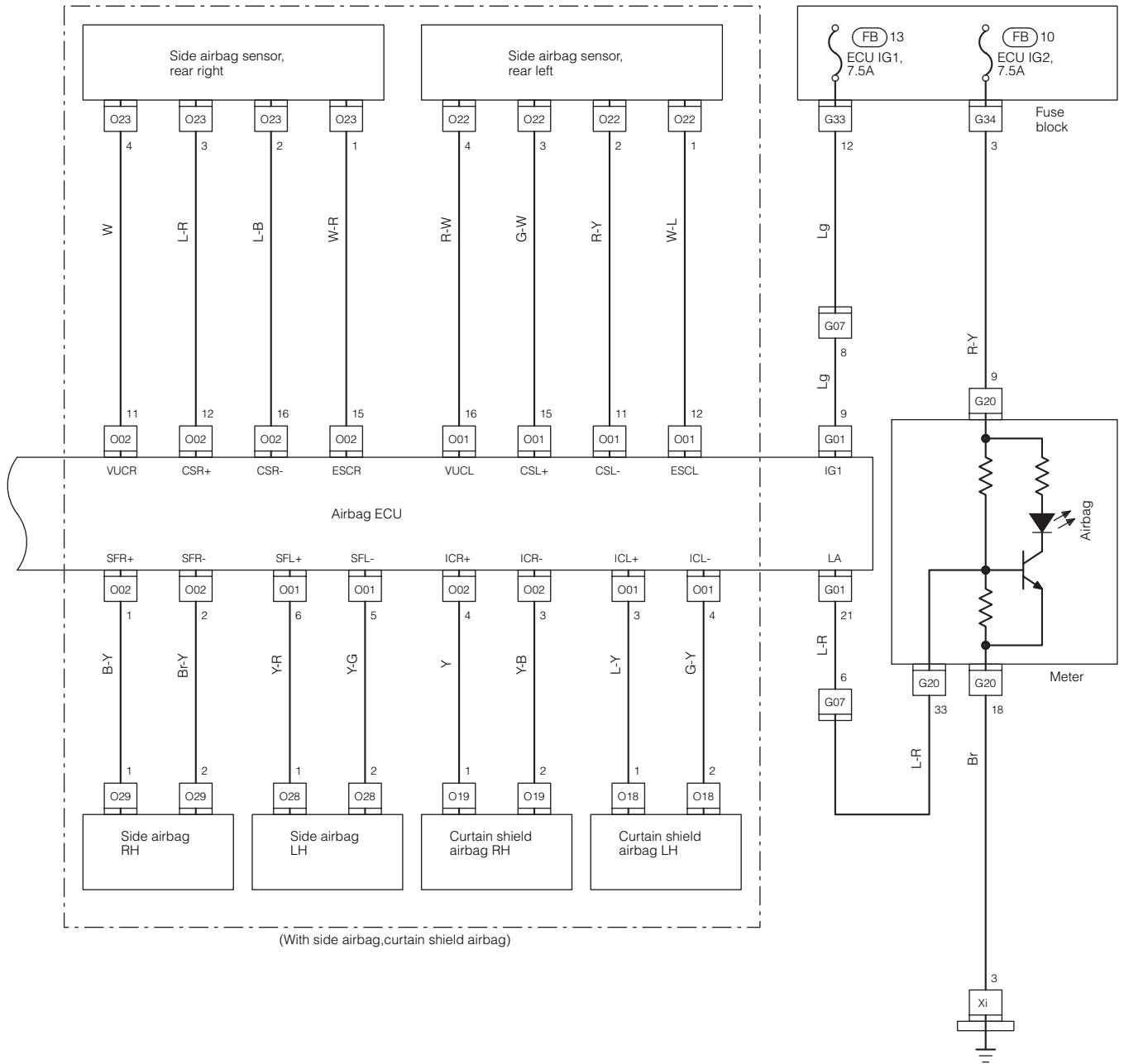

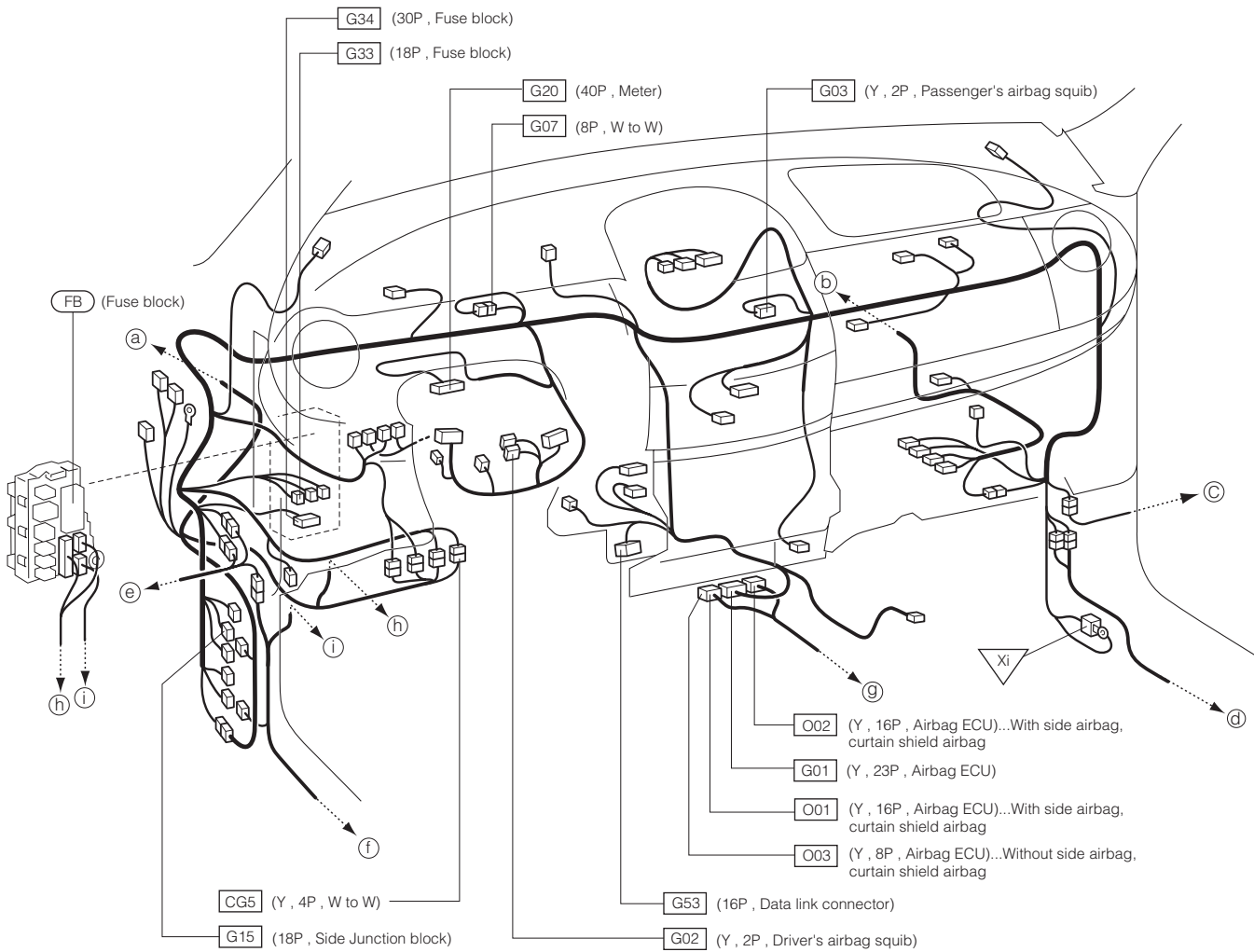

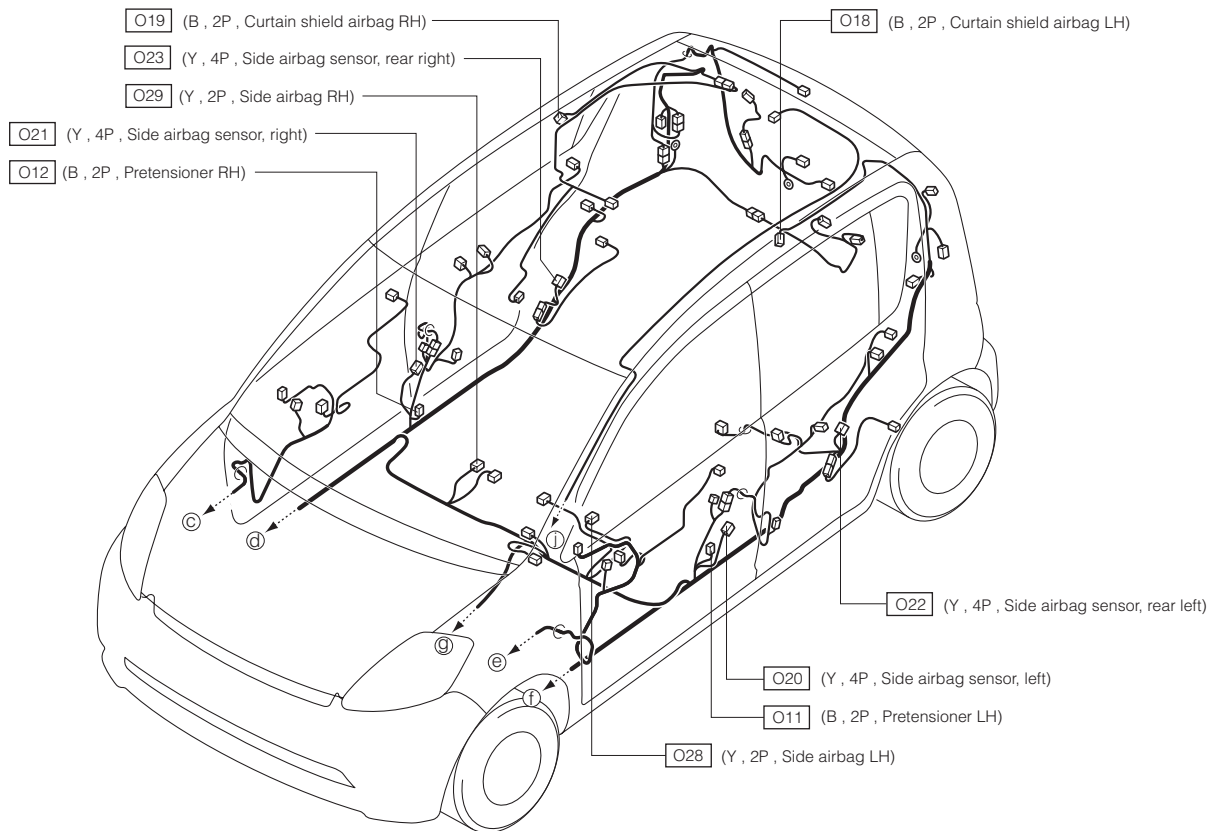
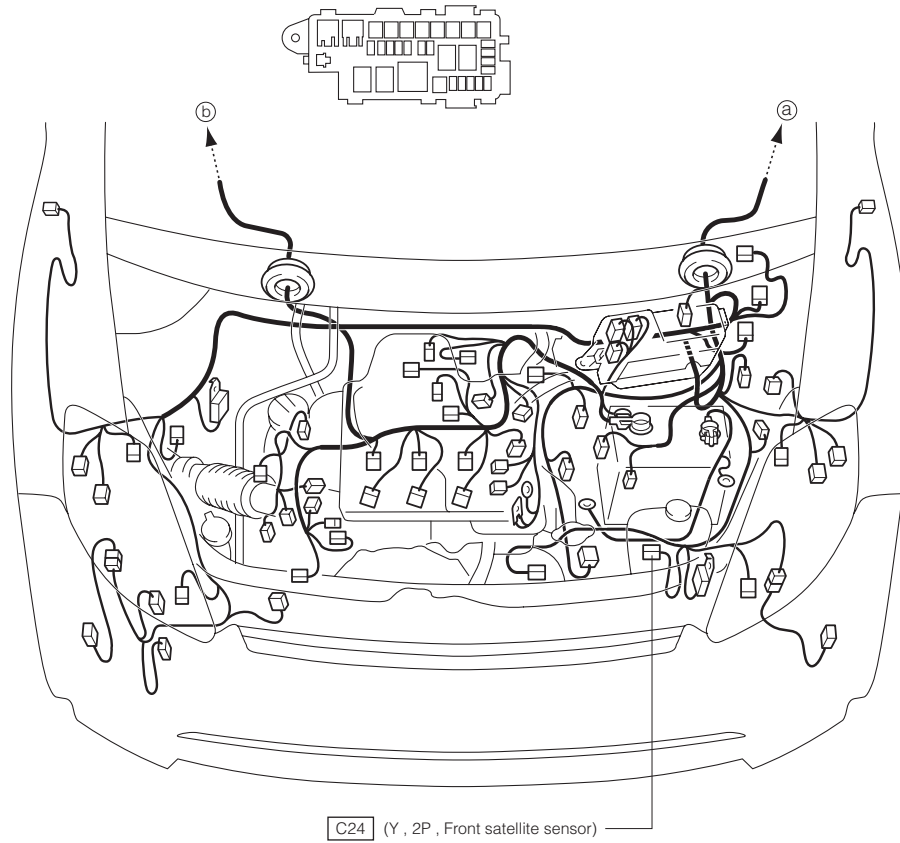

10 DOME LAMP 10-1 RHD VEHICLE

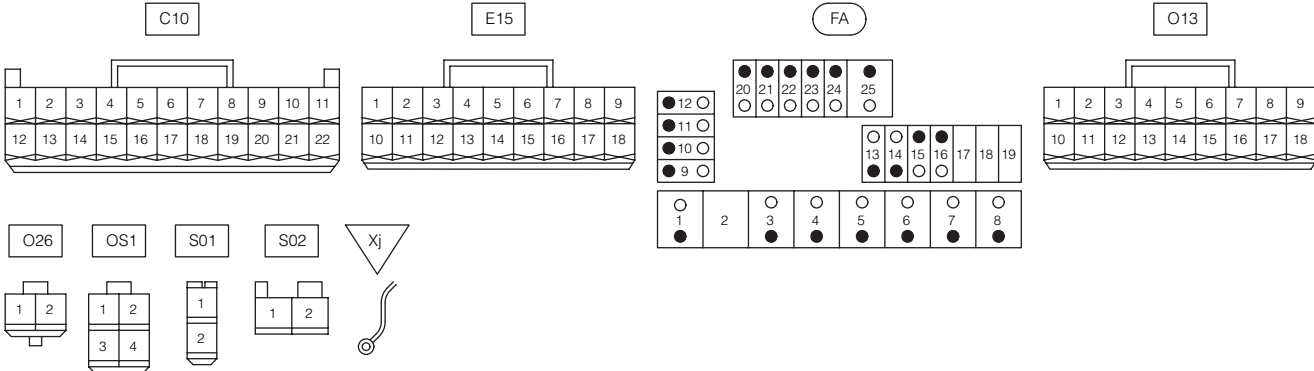
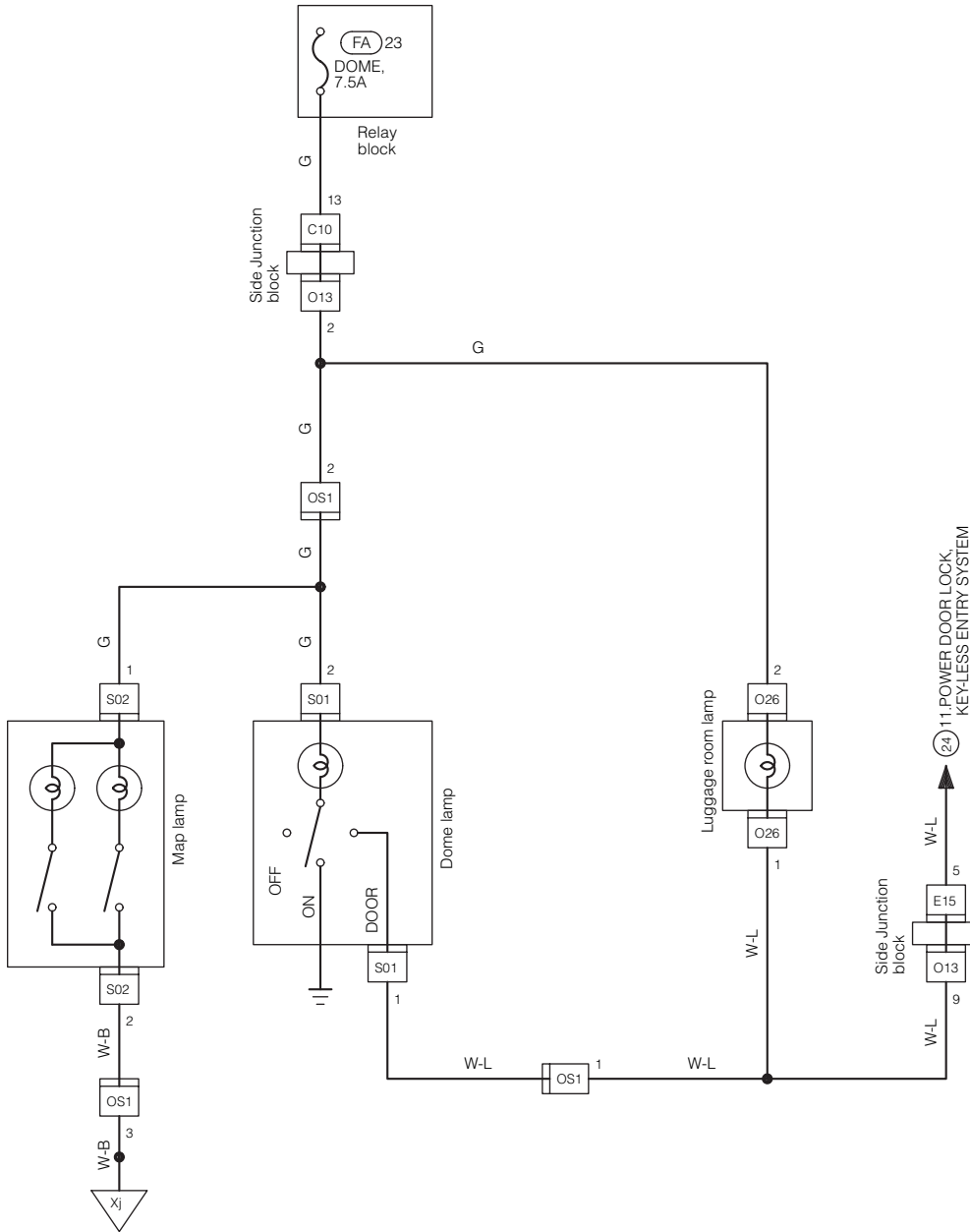

(MEMO)

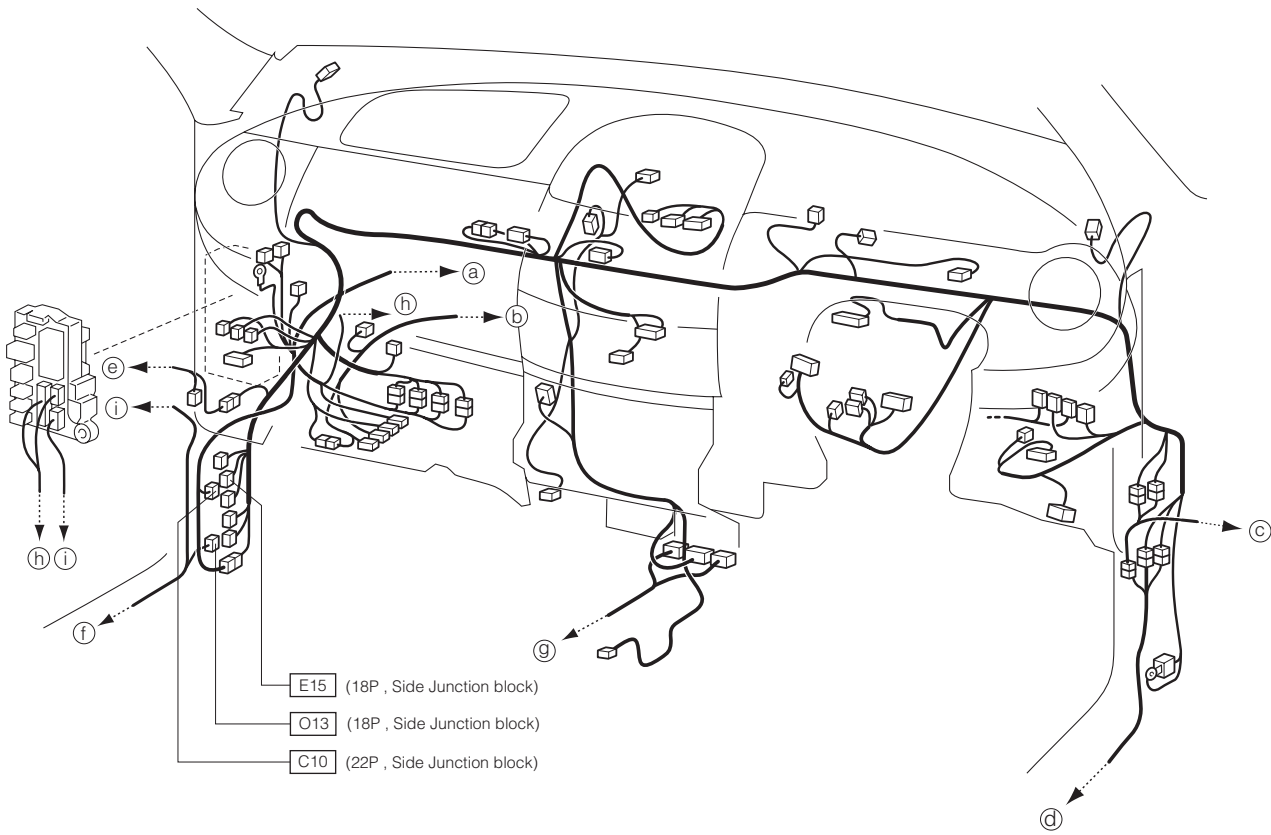

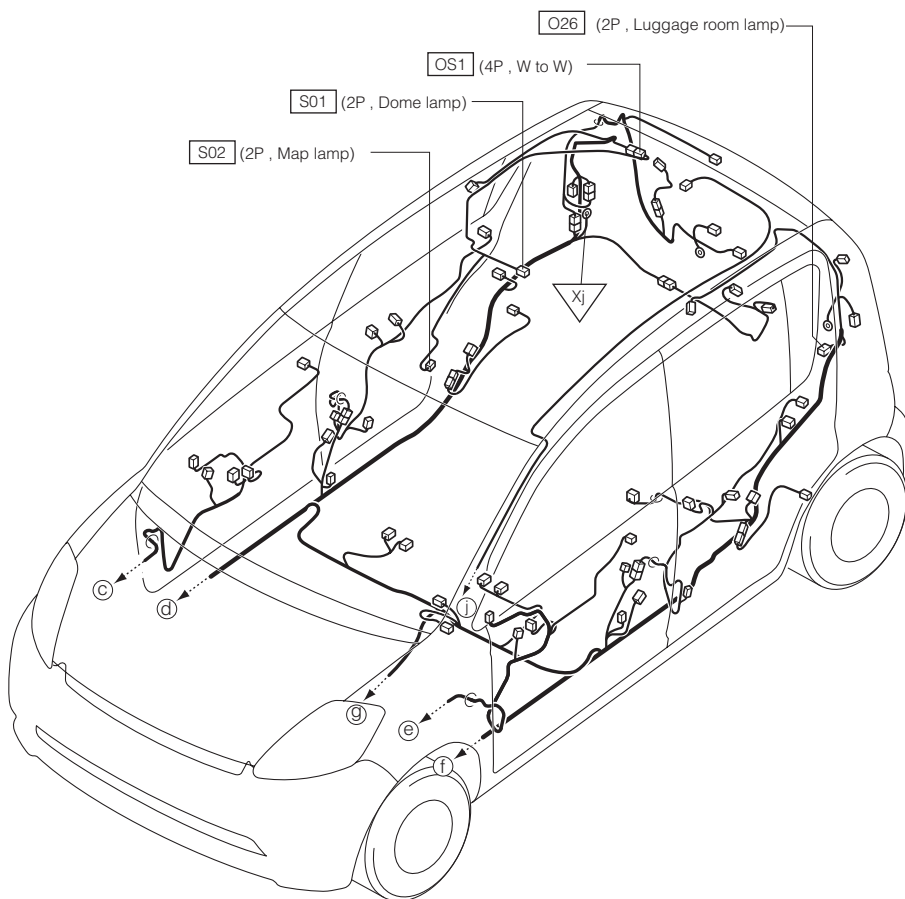
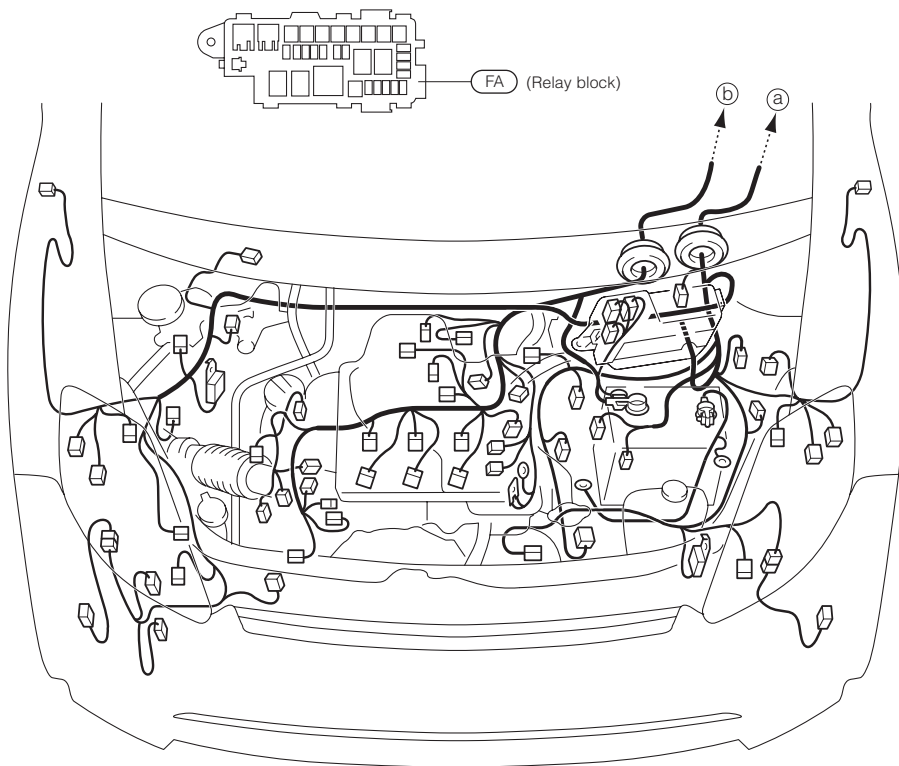

10-2 LHD VEHICLE

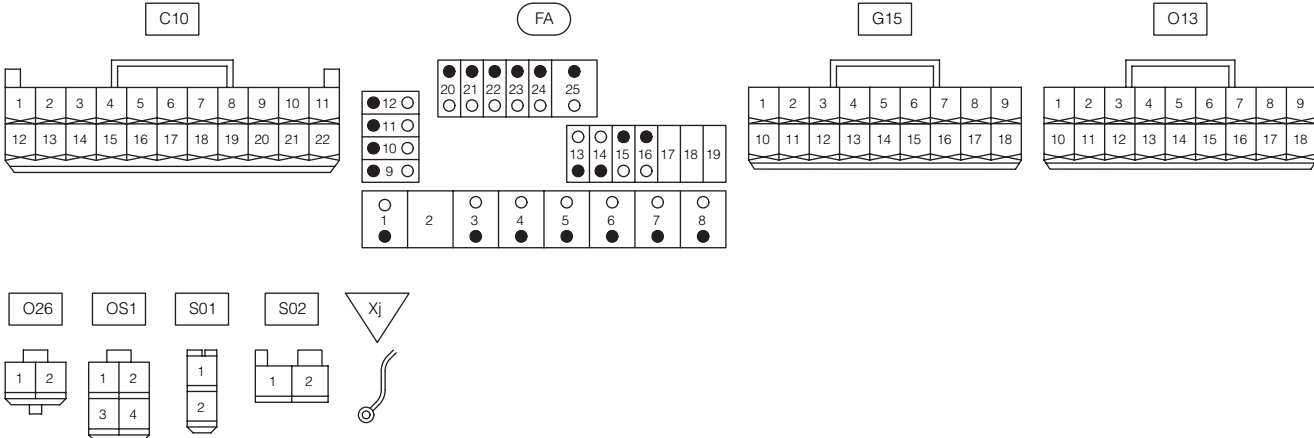
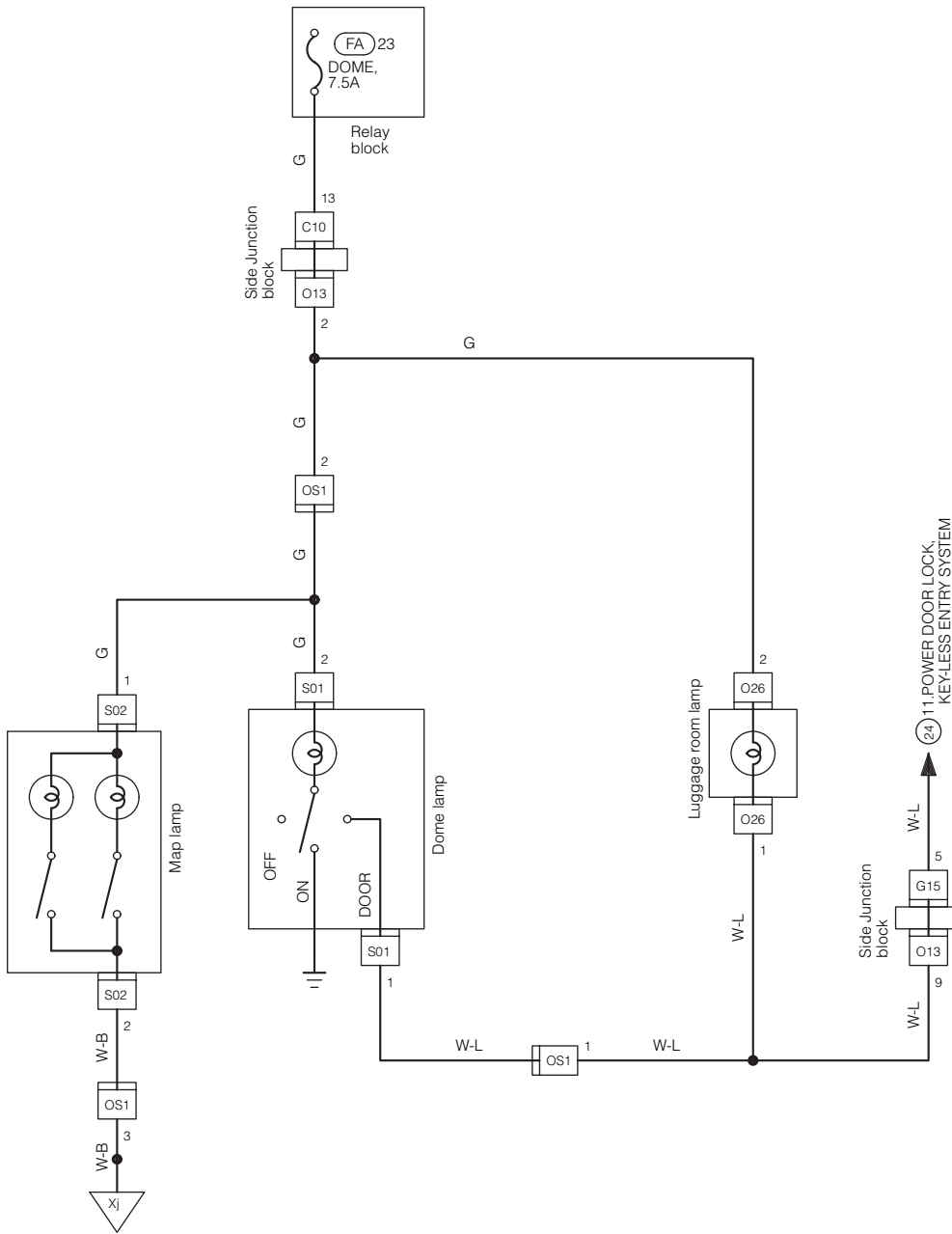

(MEMO)

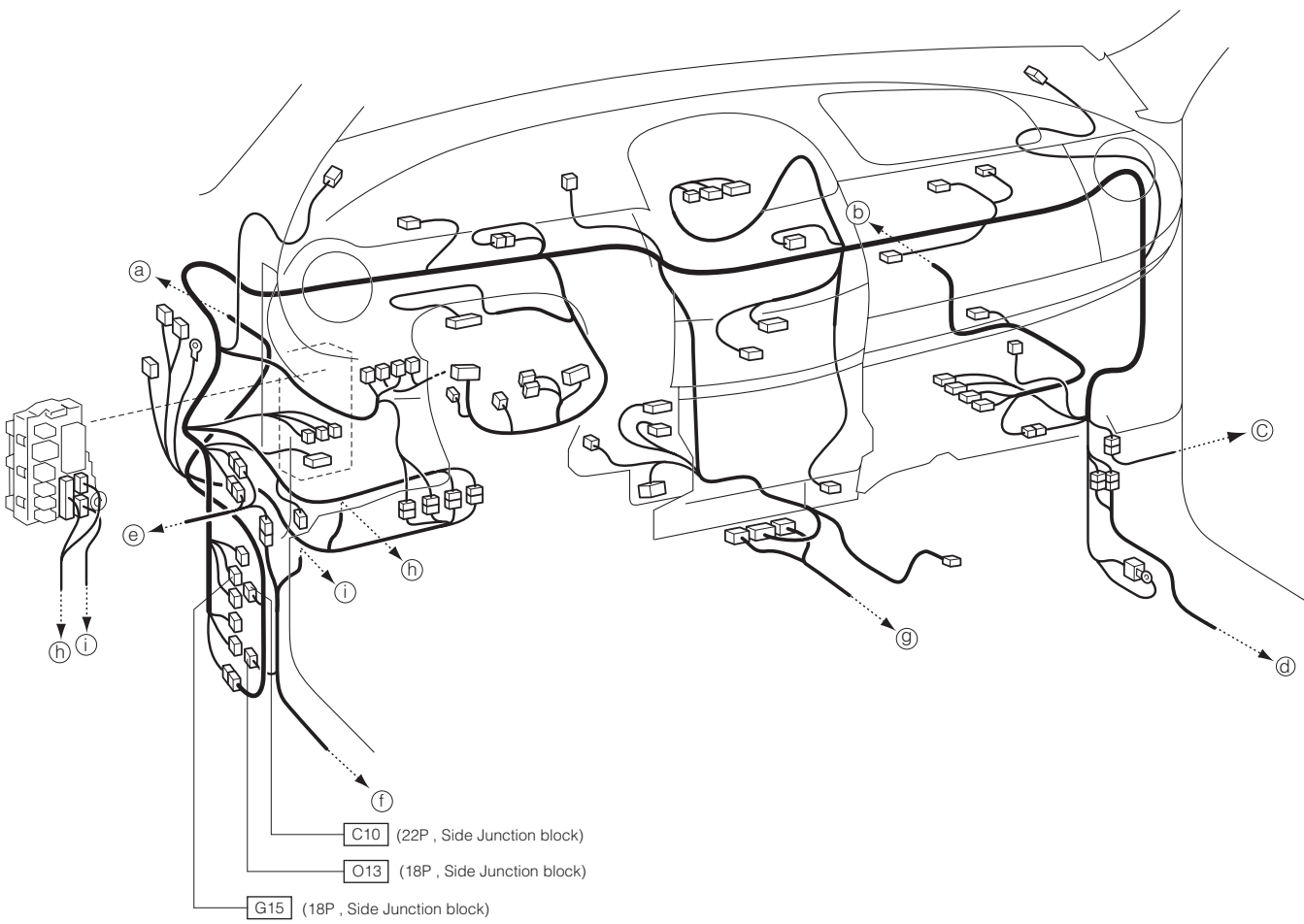

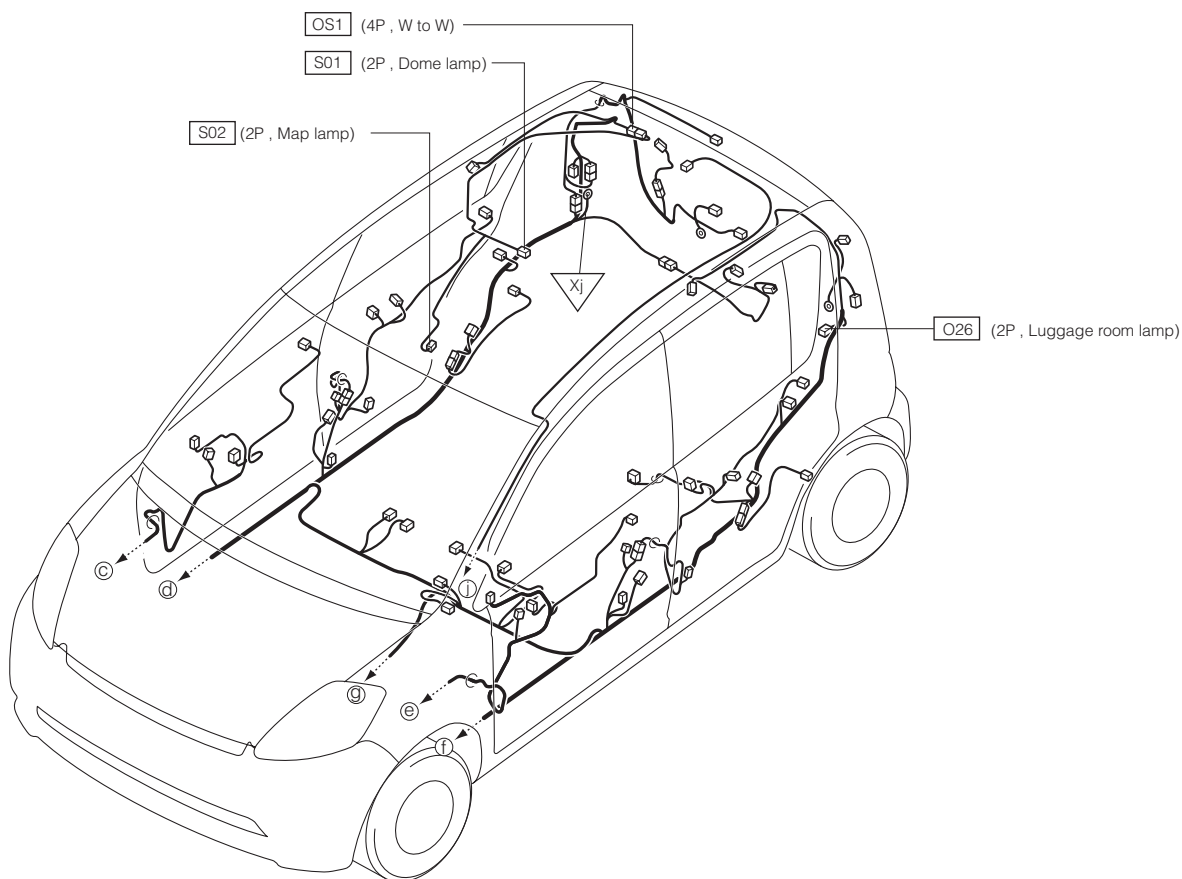
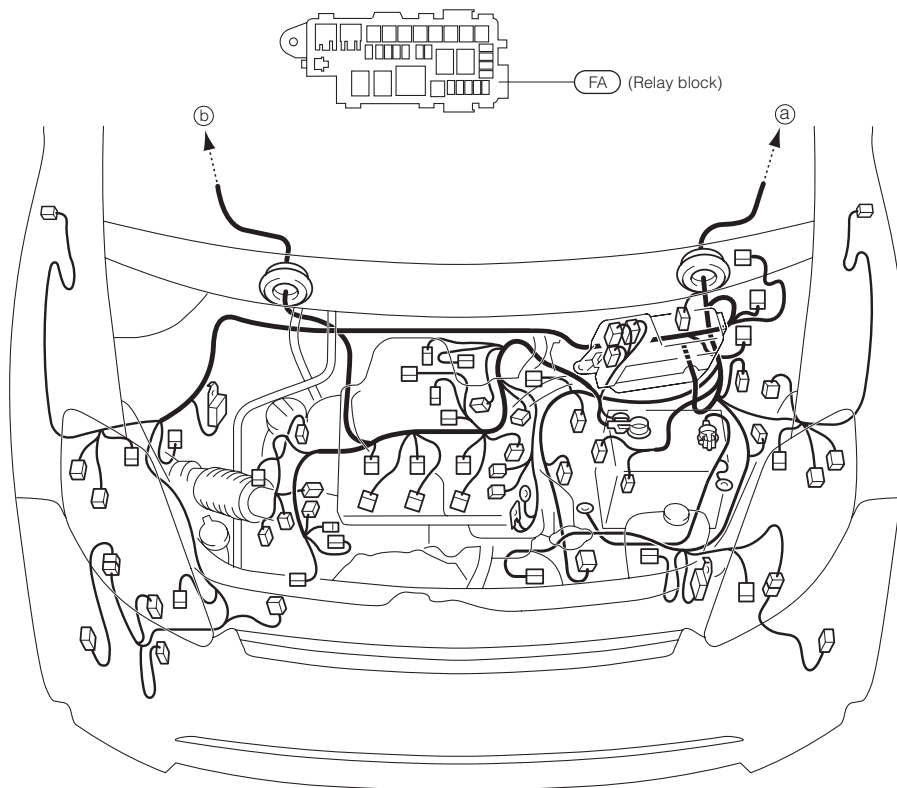

11 POWER DOOR LOCK, KEY-LESS ENTRY SYSTEM

11-1 RHD VEHICLE

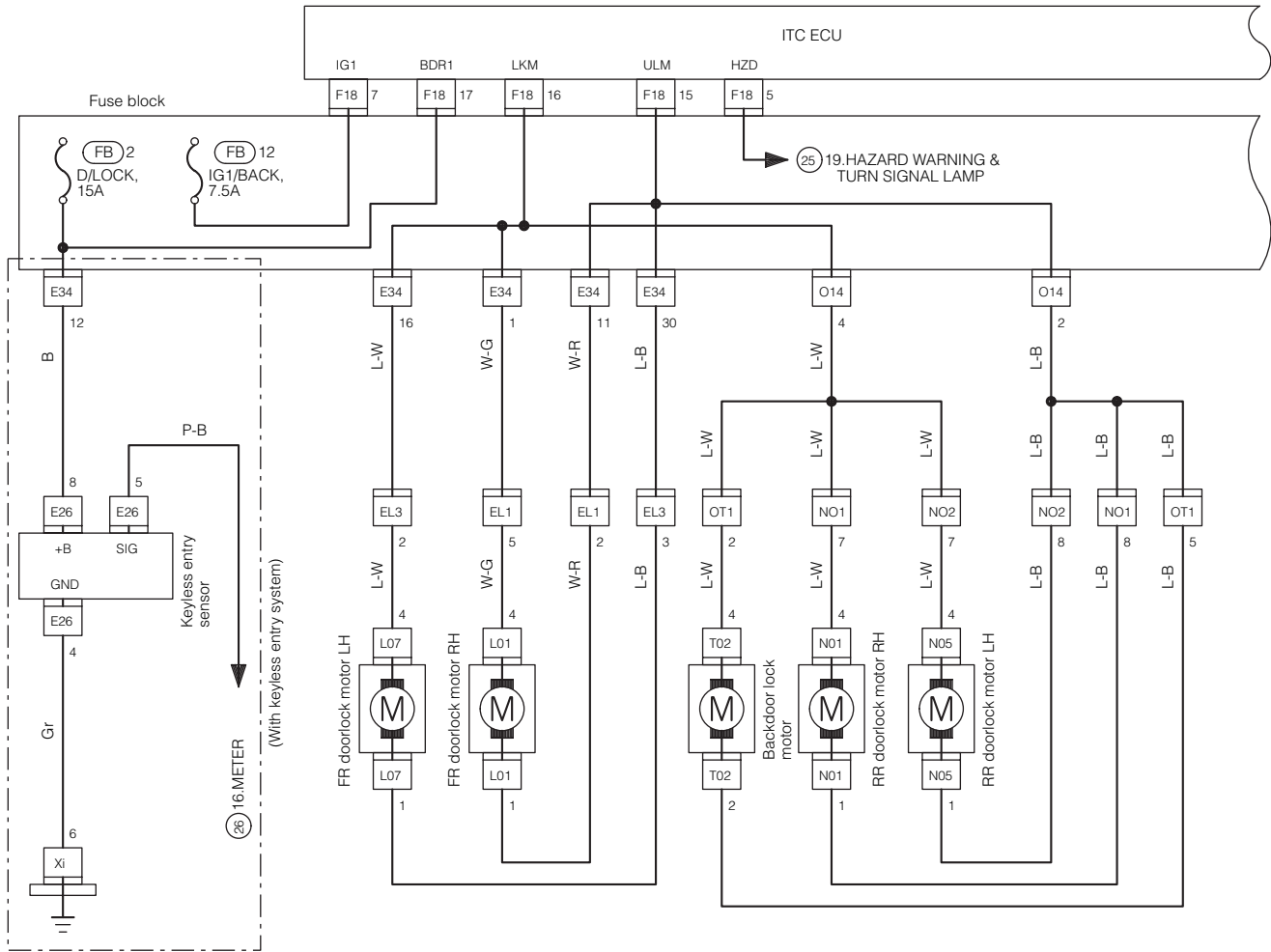

The hazard lamp having the answer back function is described in '19.Hazard Warning & Turn Signal Lamp.'

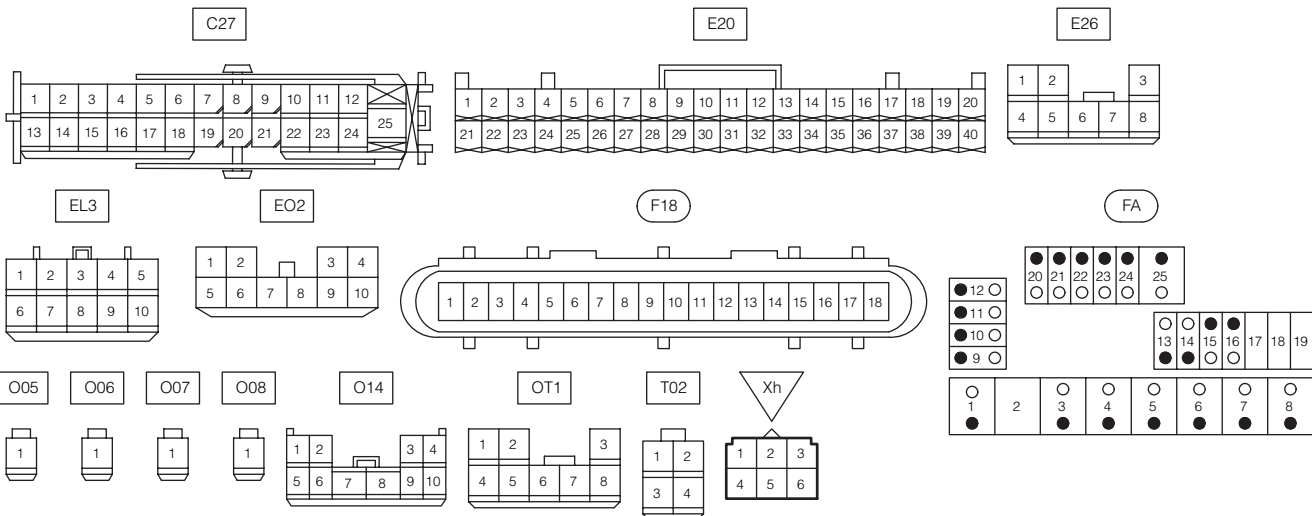

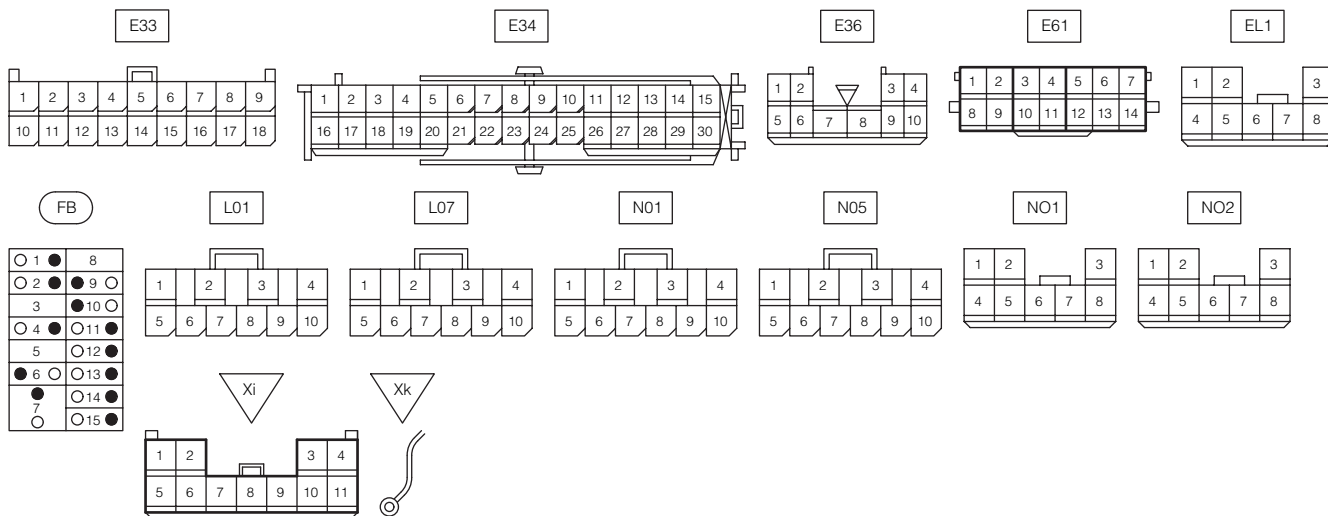
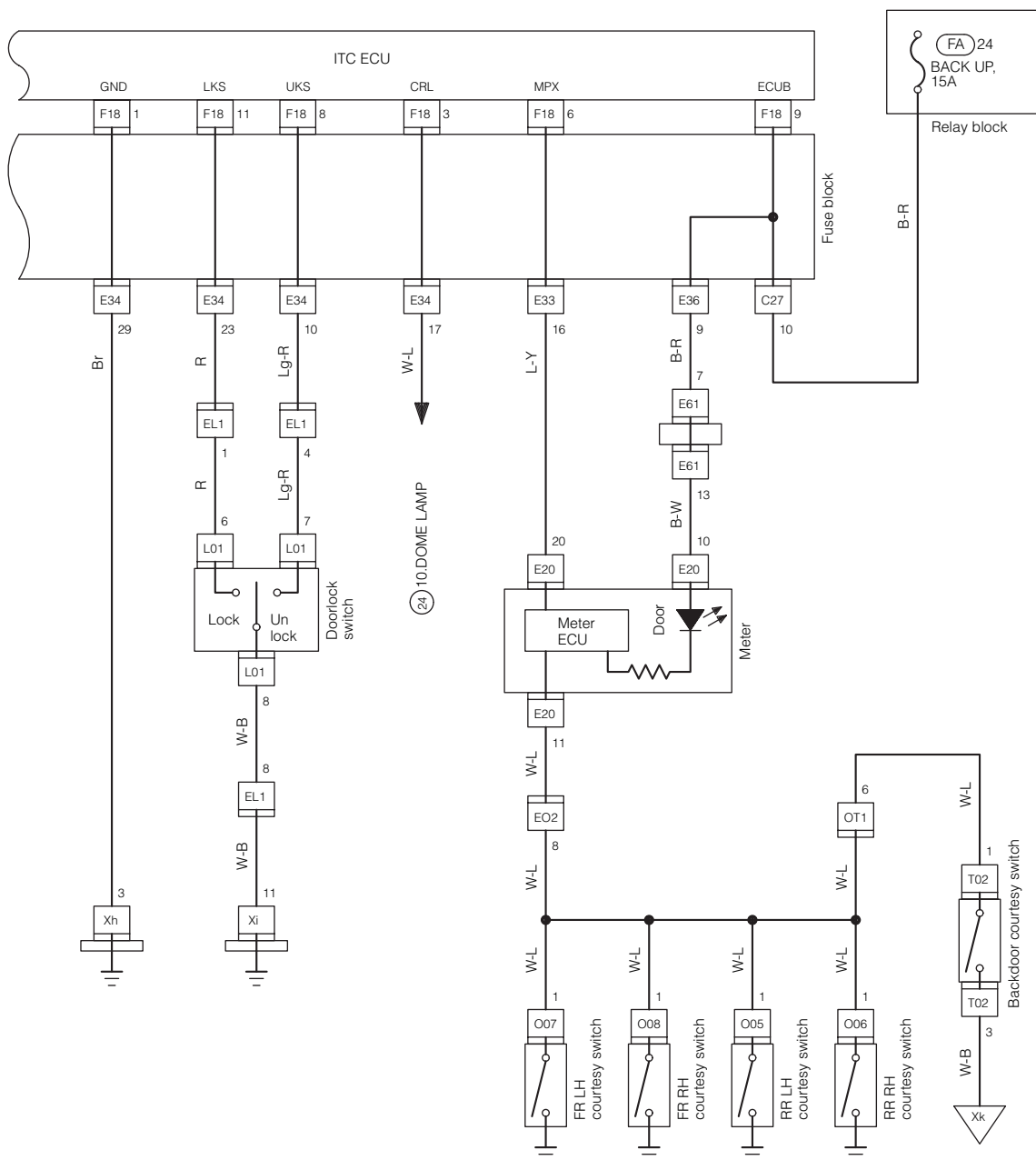

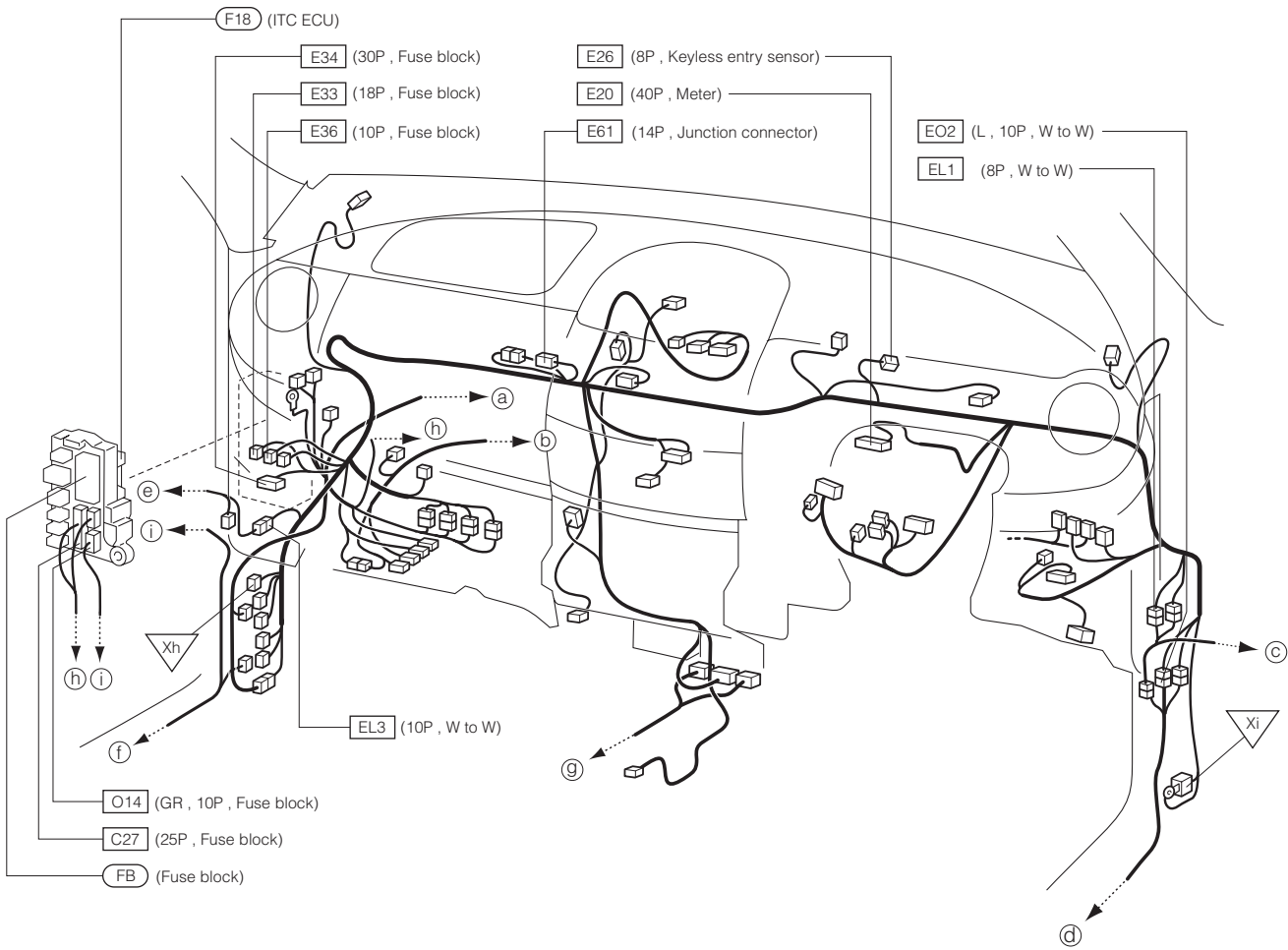

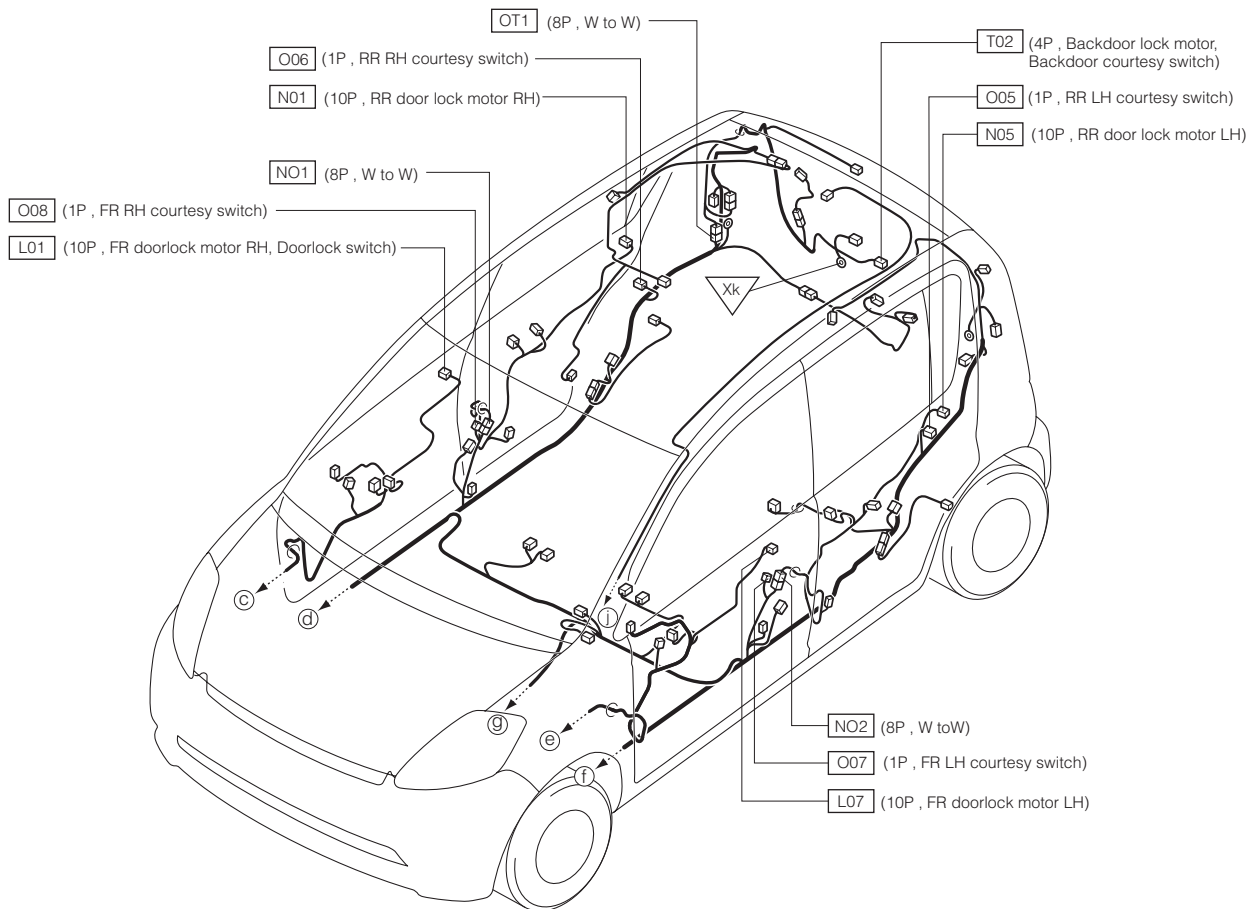
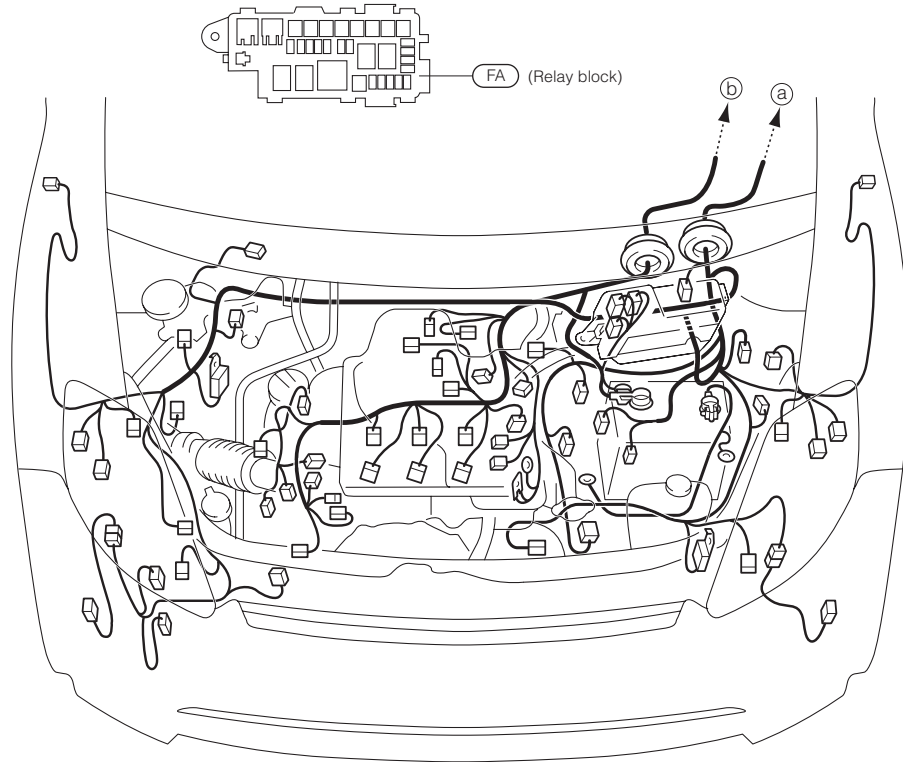

11-2 LHD VEHICLE

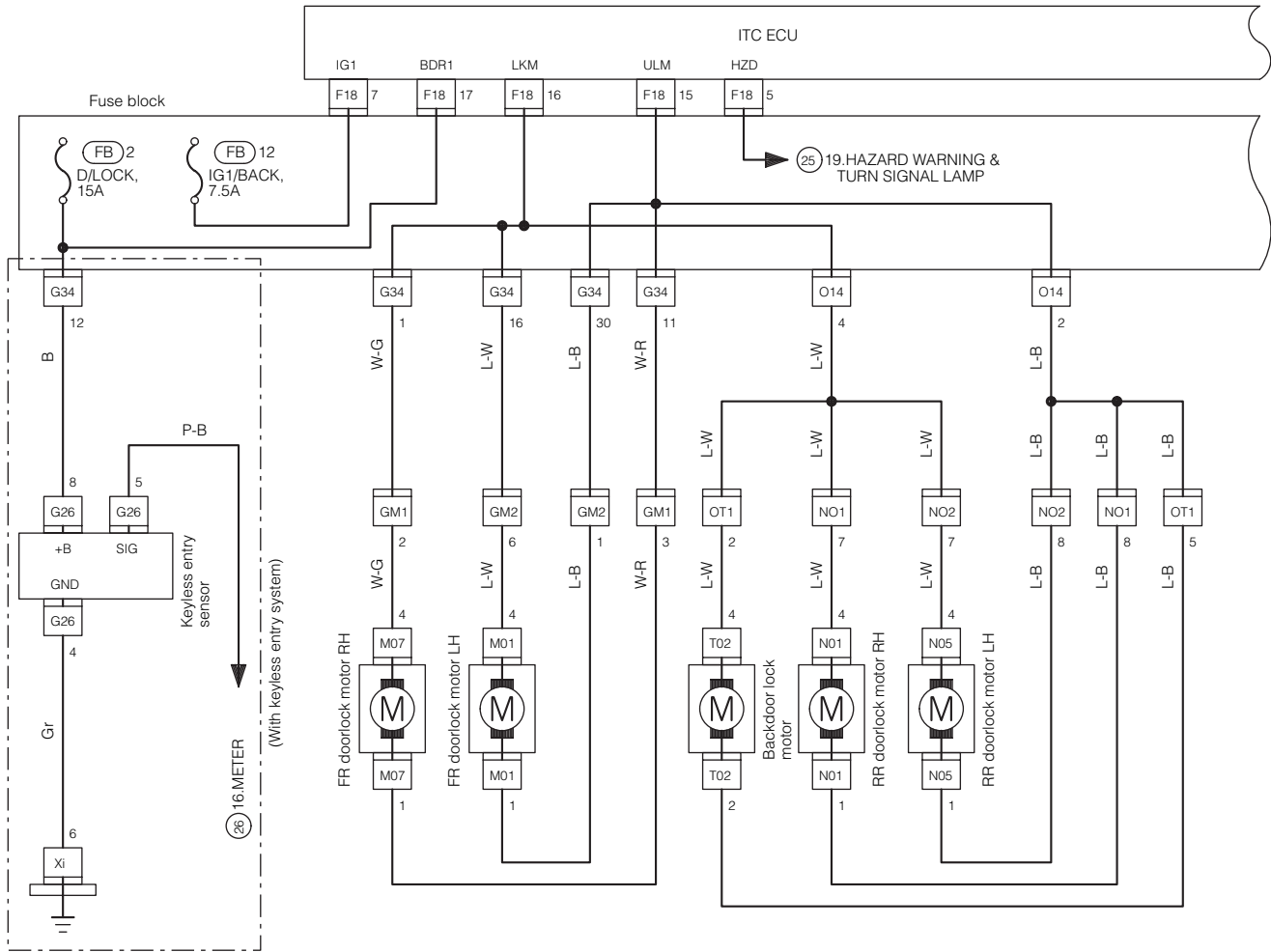

The hazard lamp having the answer back function is described in "19.Hazard Warning & Turn Signal Lamp."

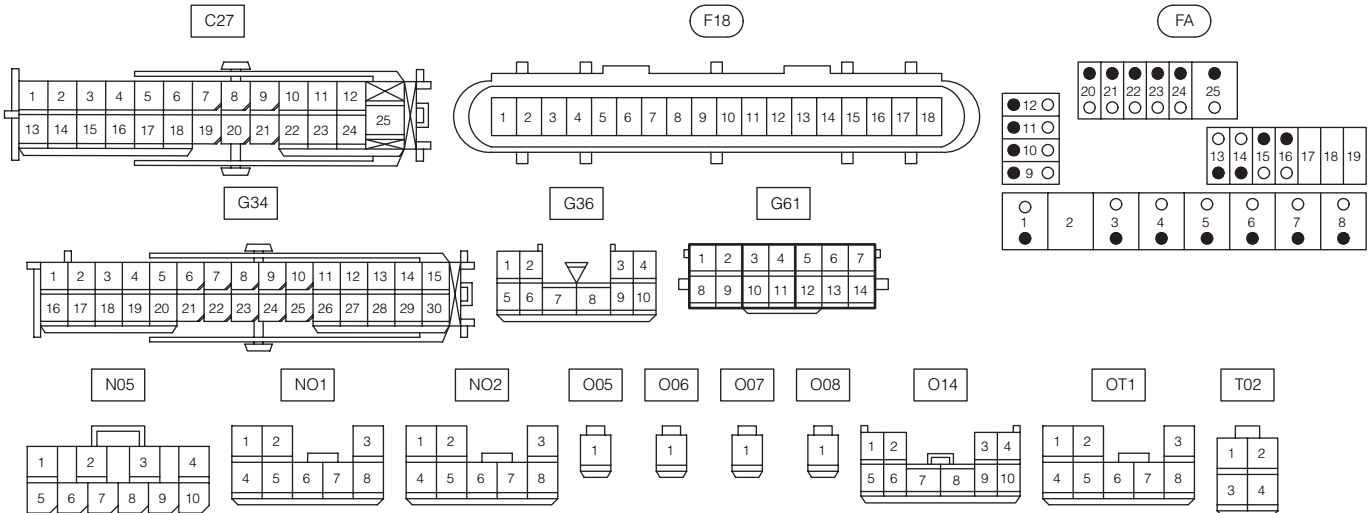

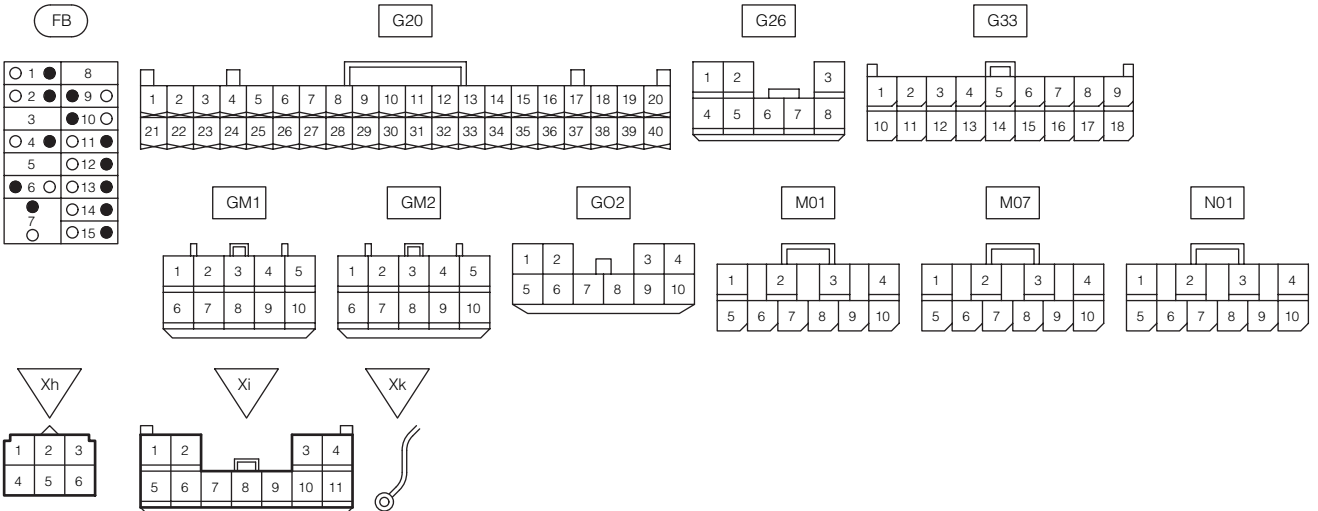
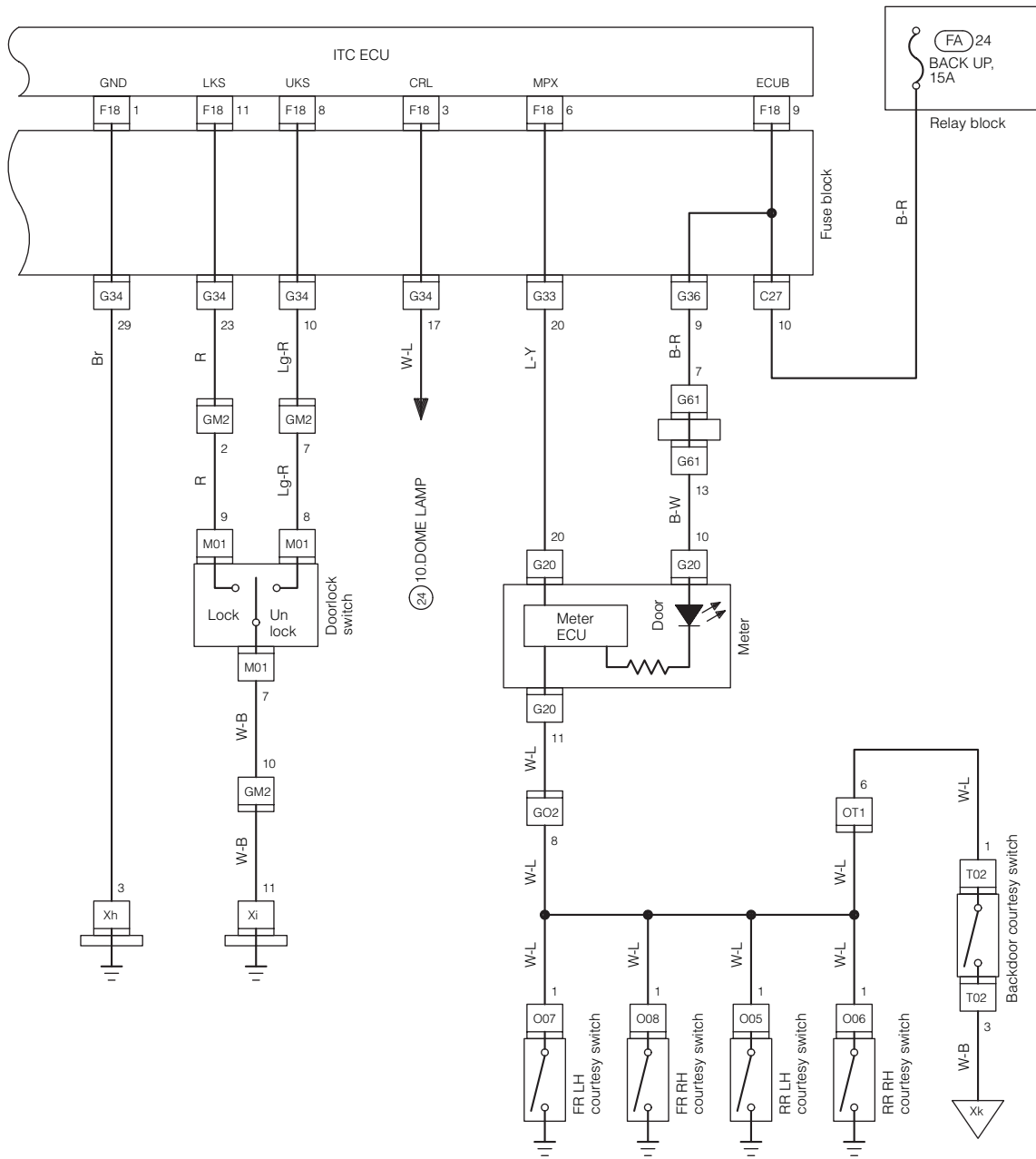

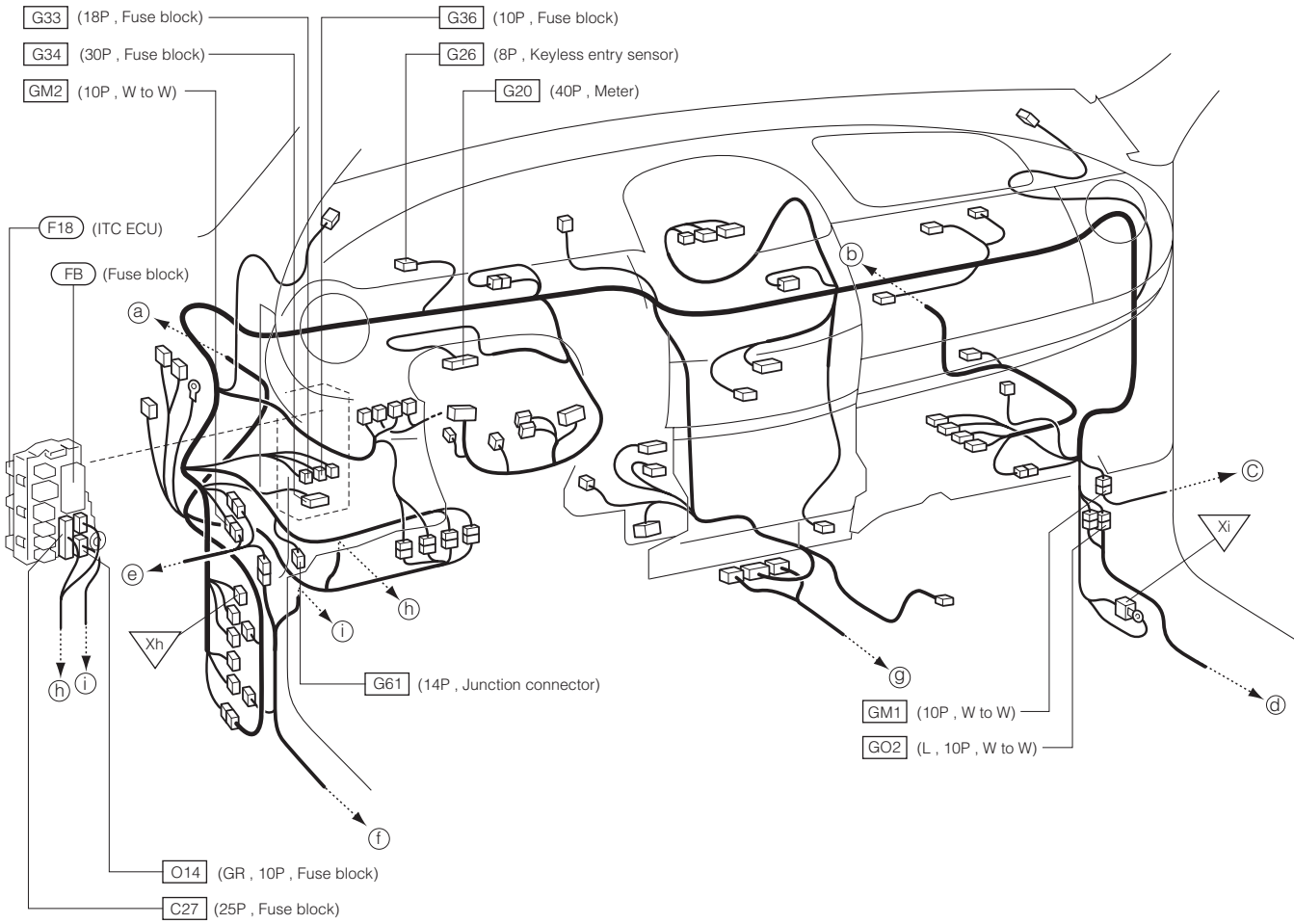

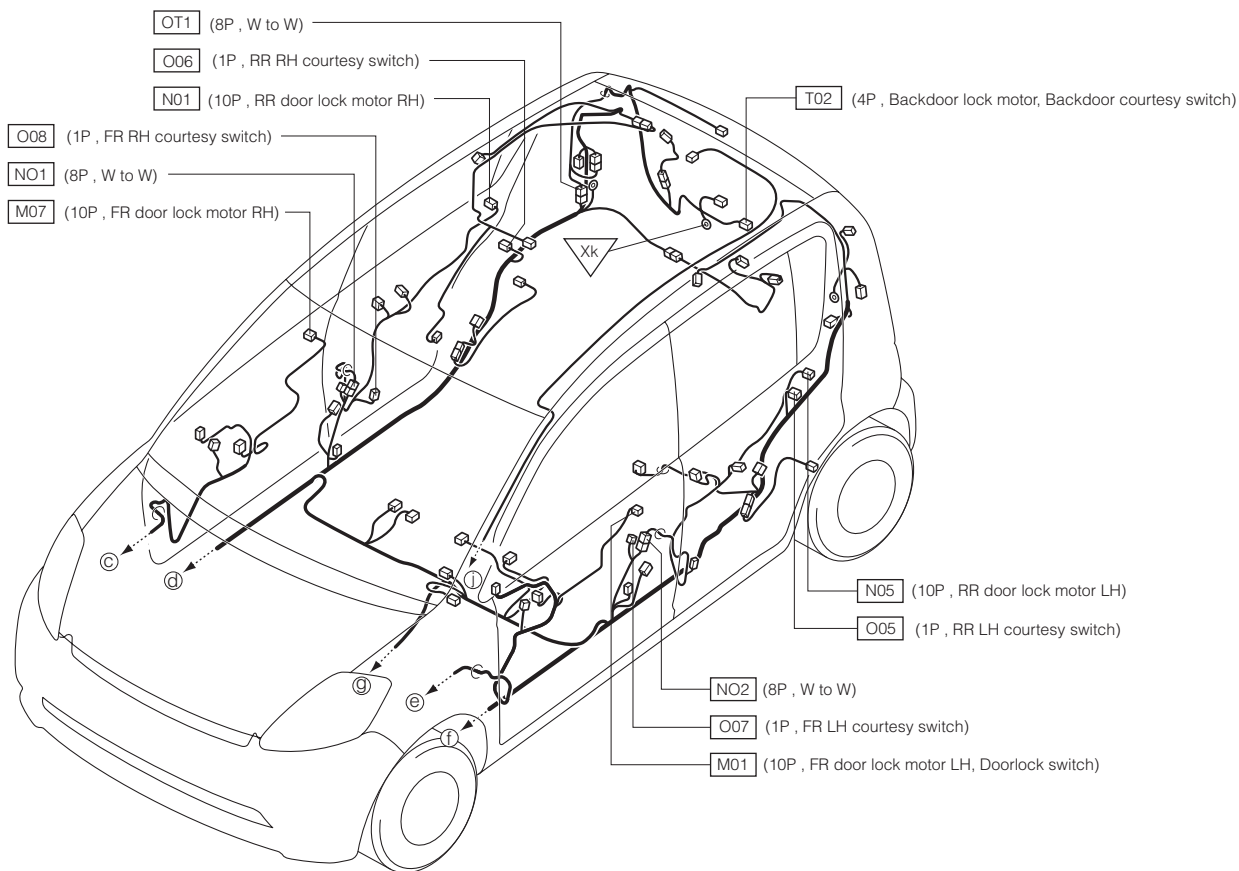
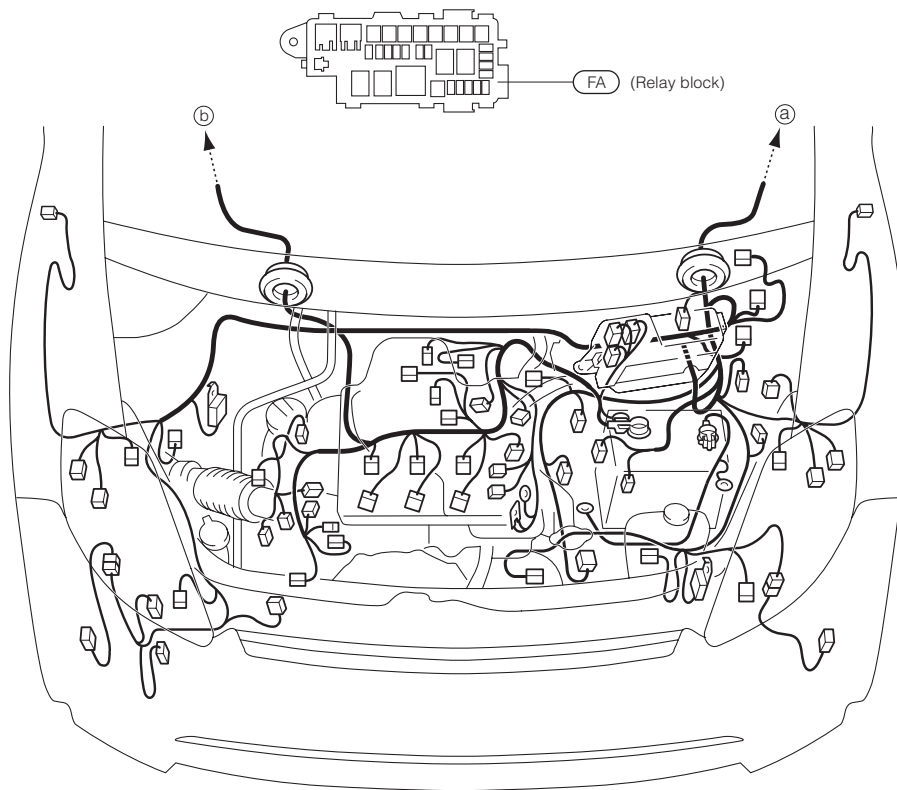

12 IMMOBILIZER SYSTEM 12-1 RHD VEHICLE

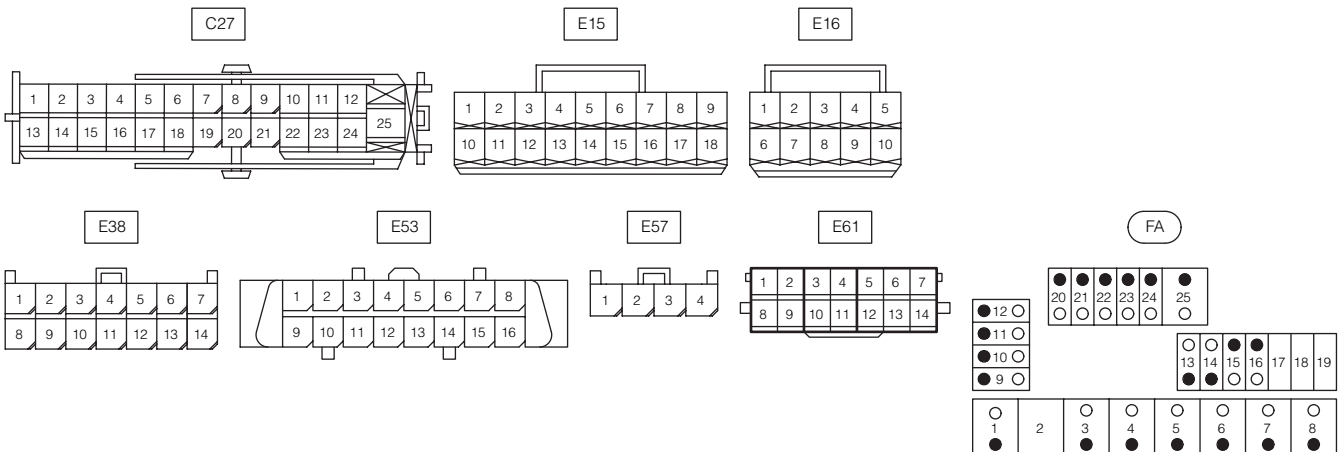
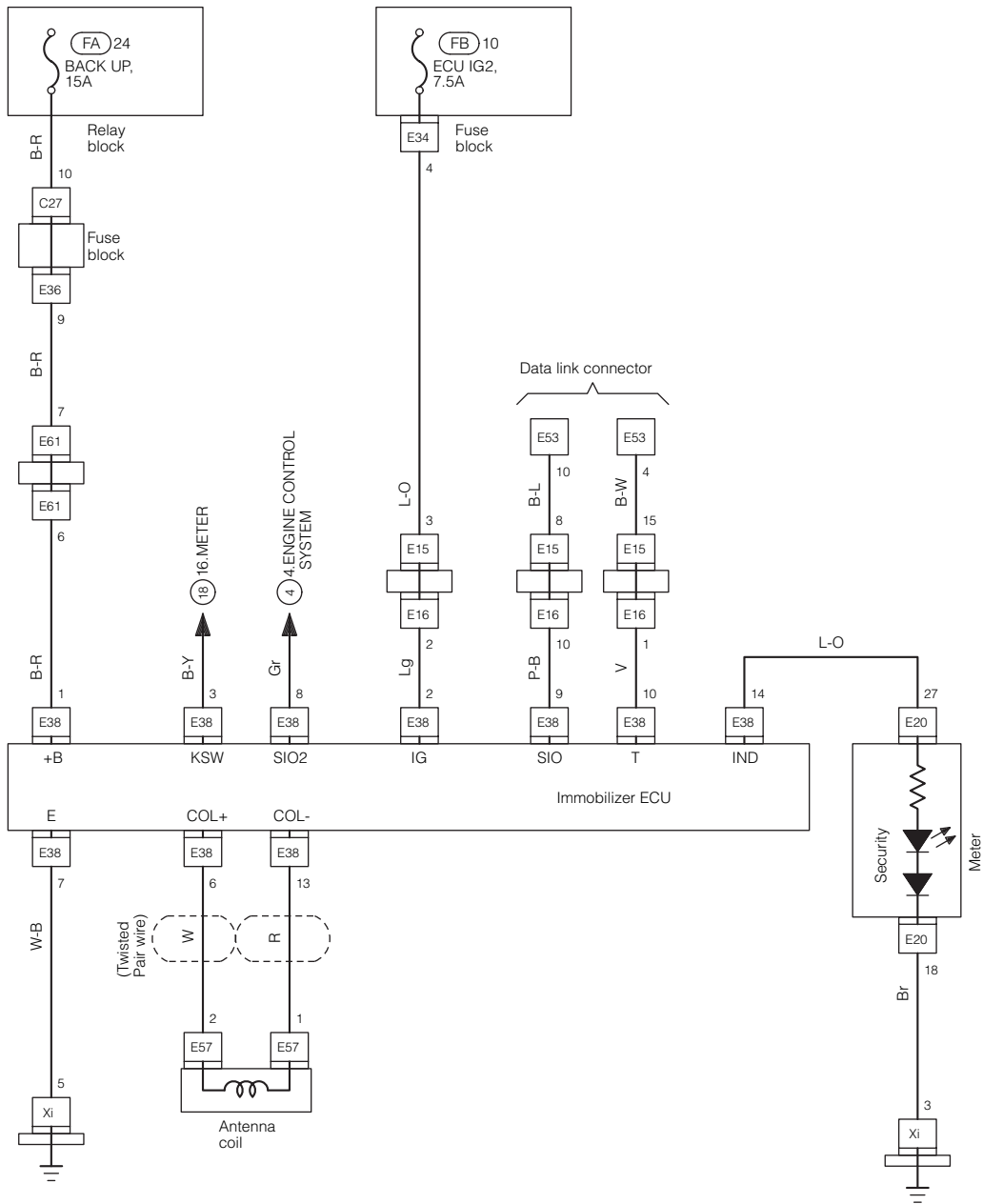

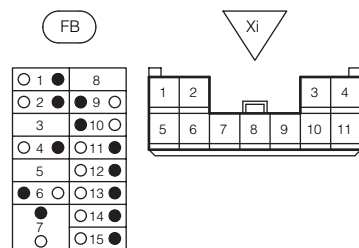
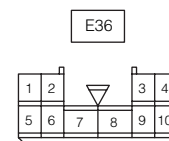
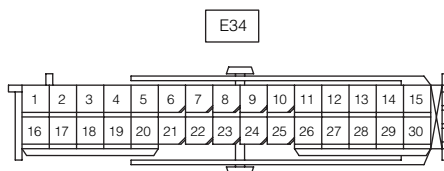
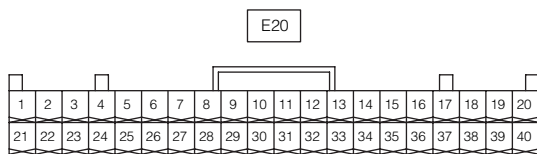

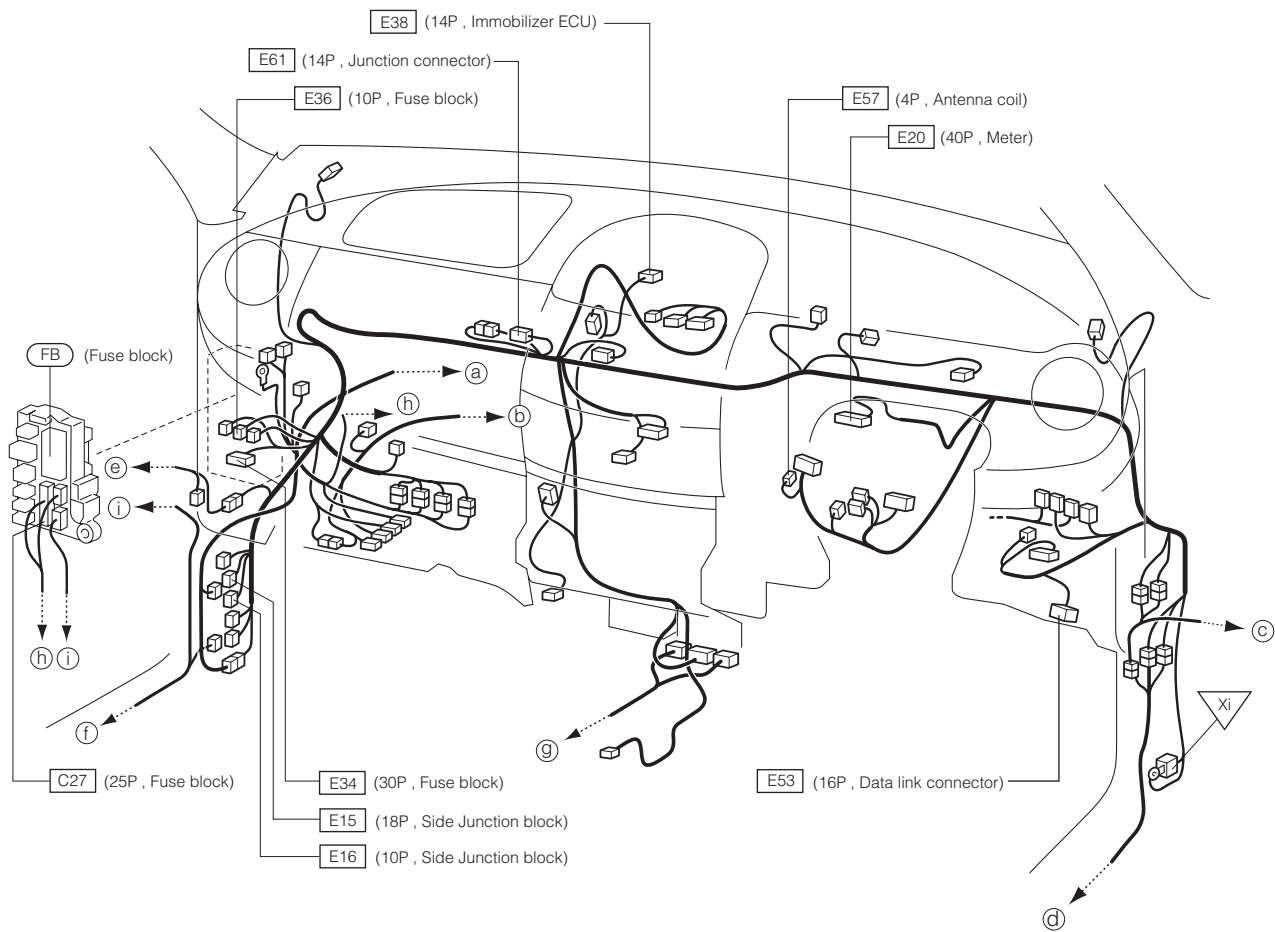

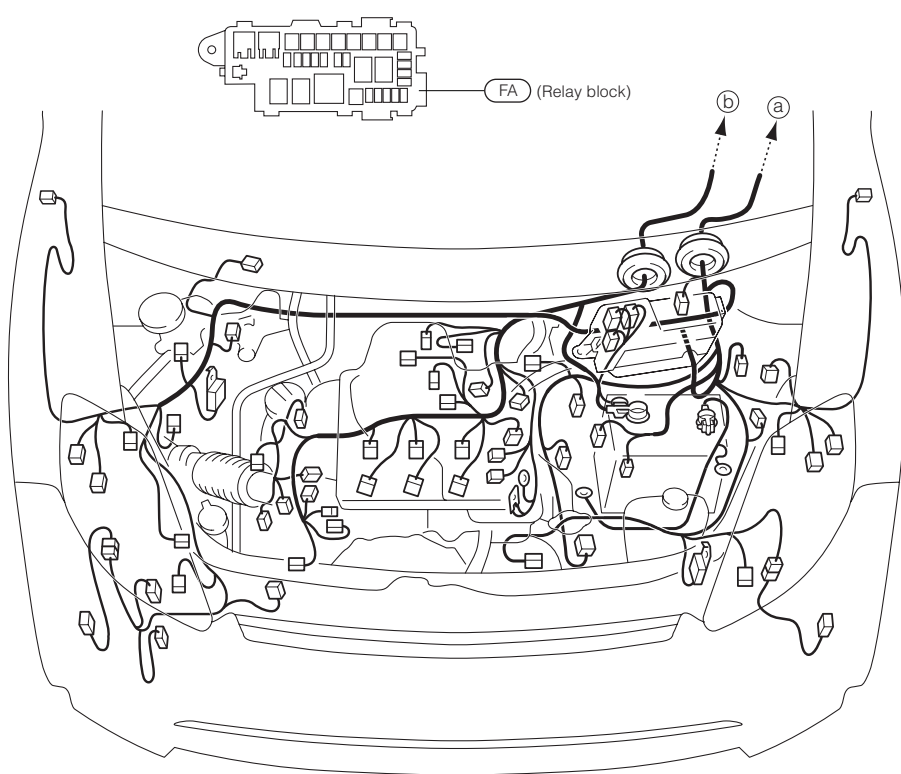

12-2 LHD VEHICLE

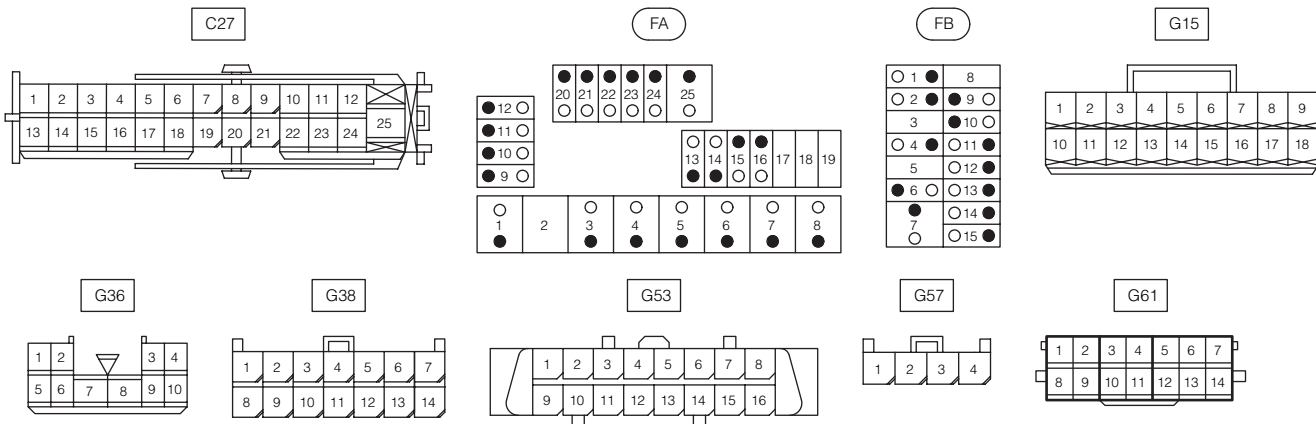
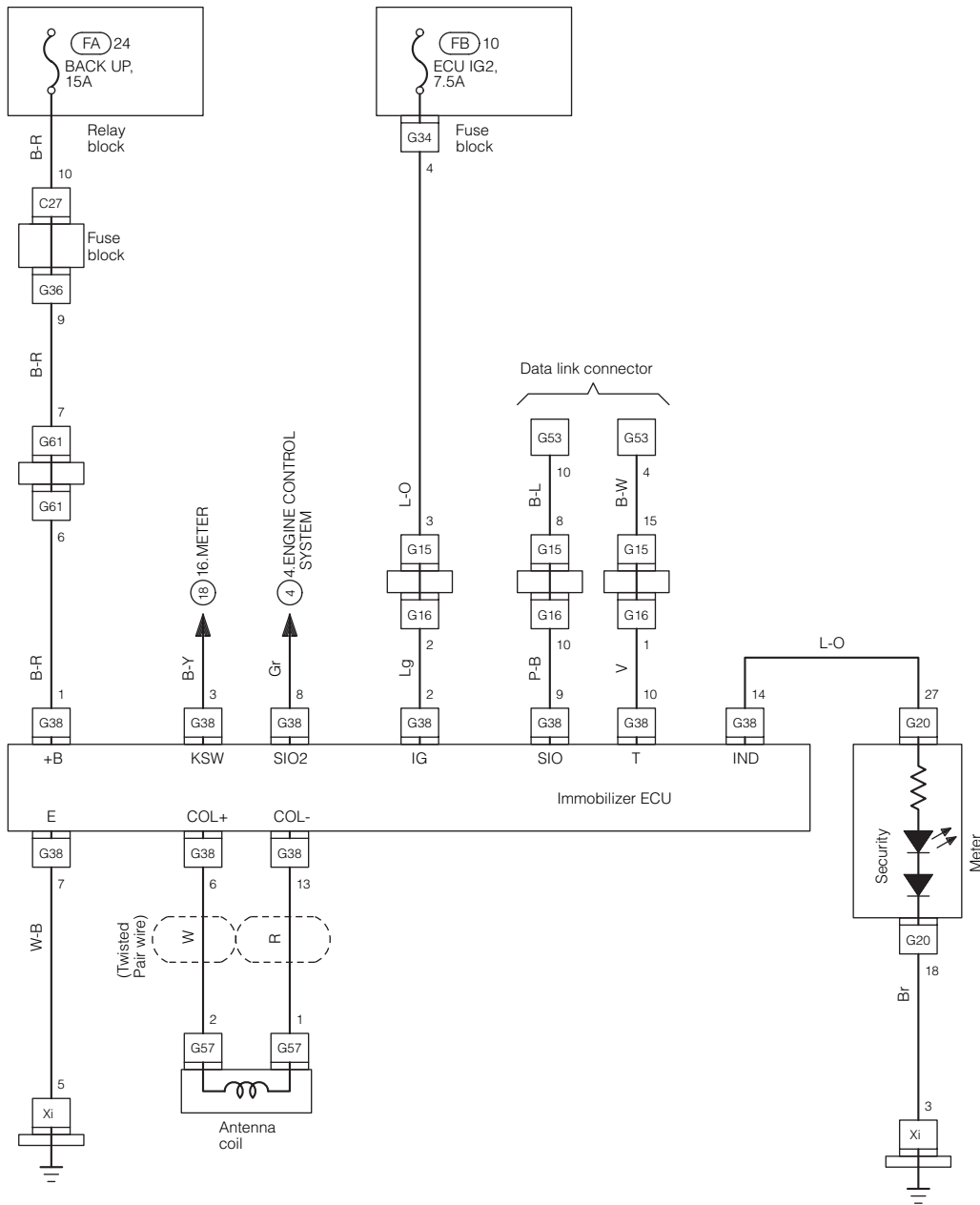

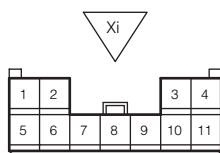
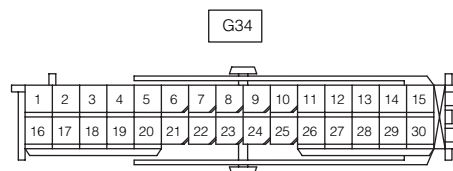
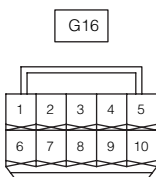

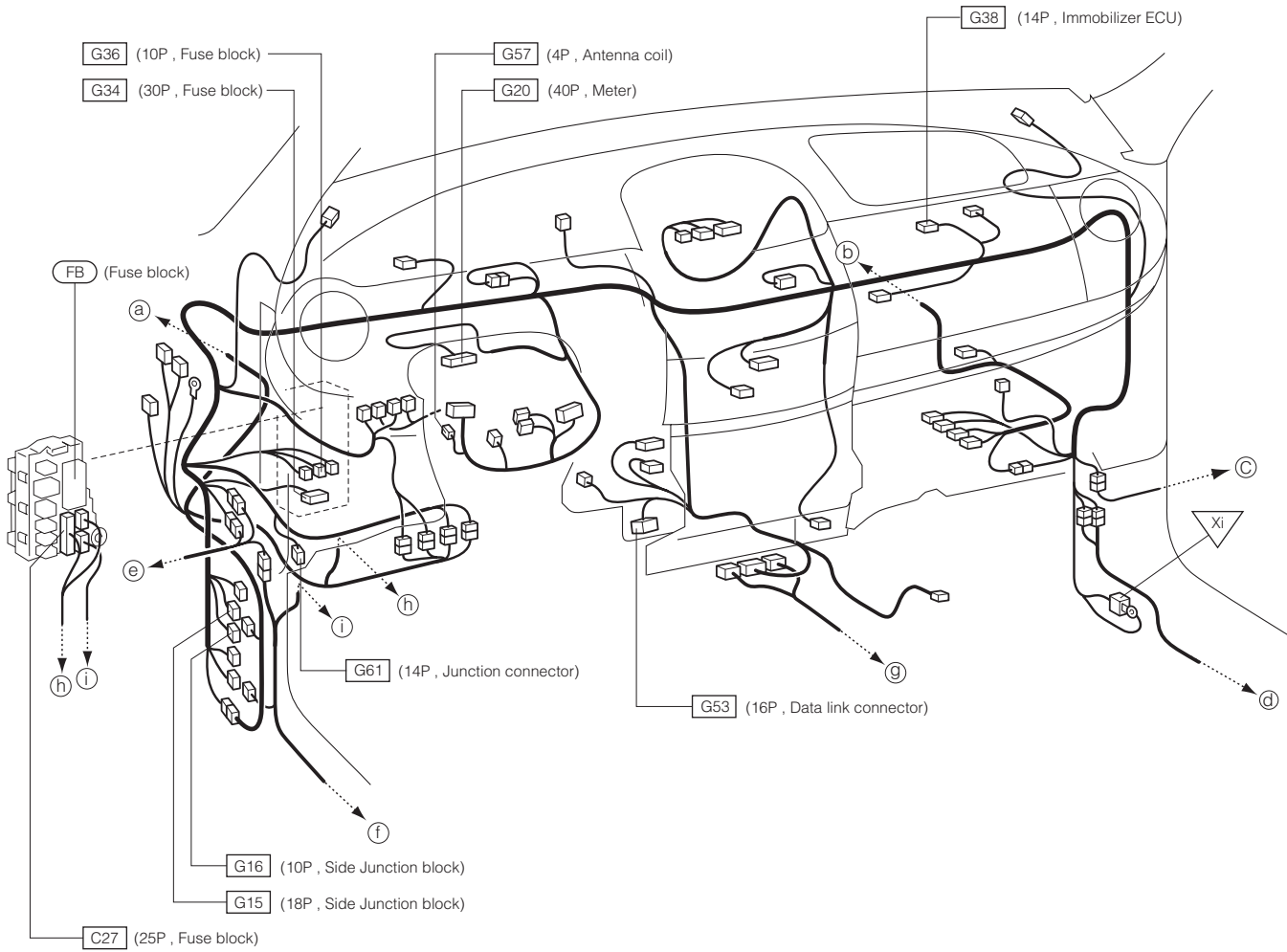

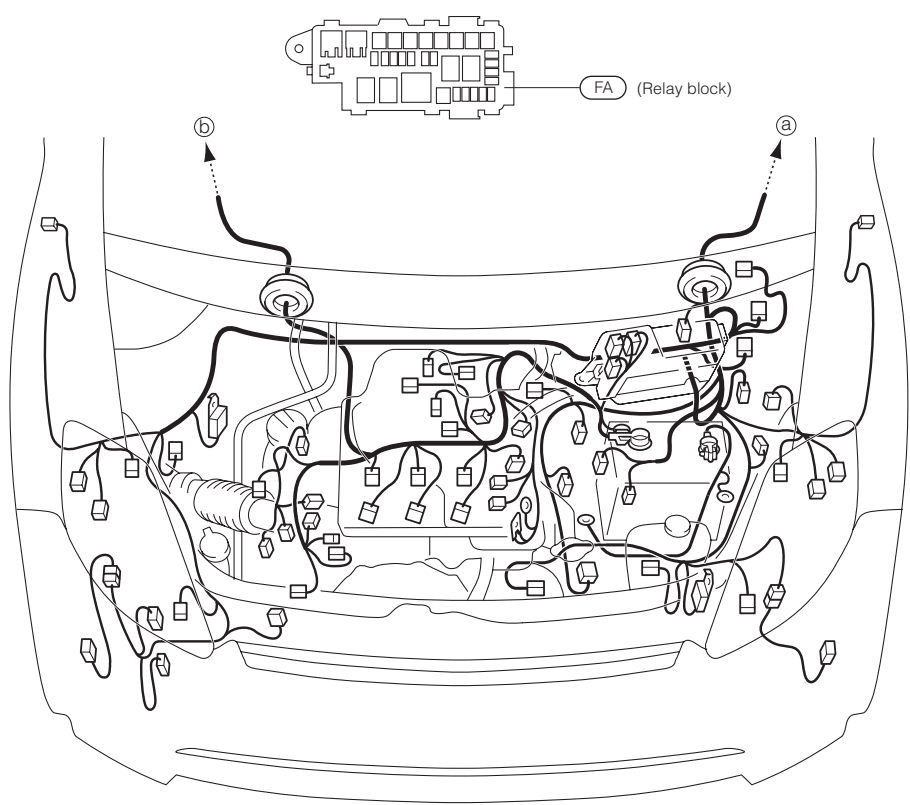

13 OUTER REAR-VIEW MIRROR 13-1 RHD VEHICLE

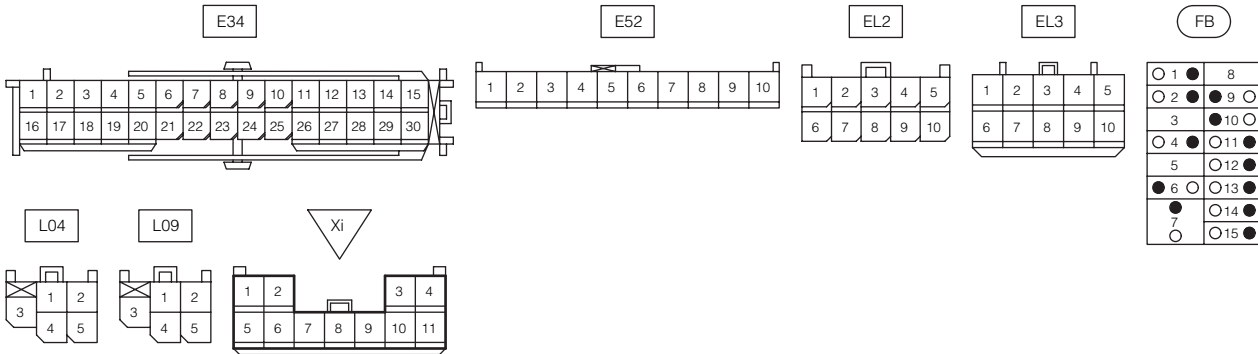
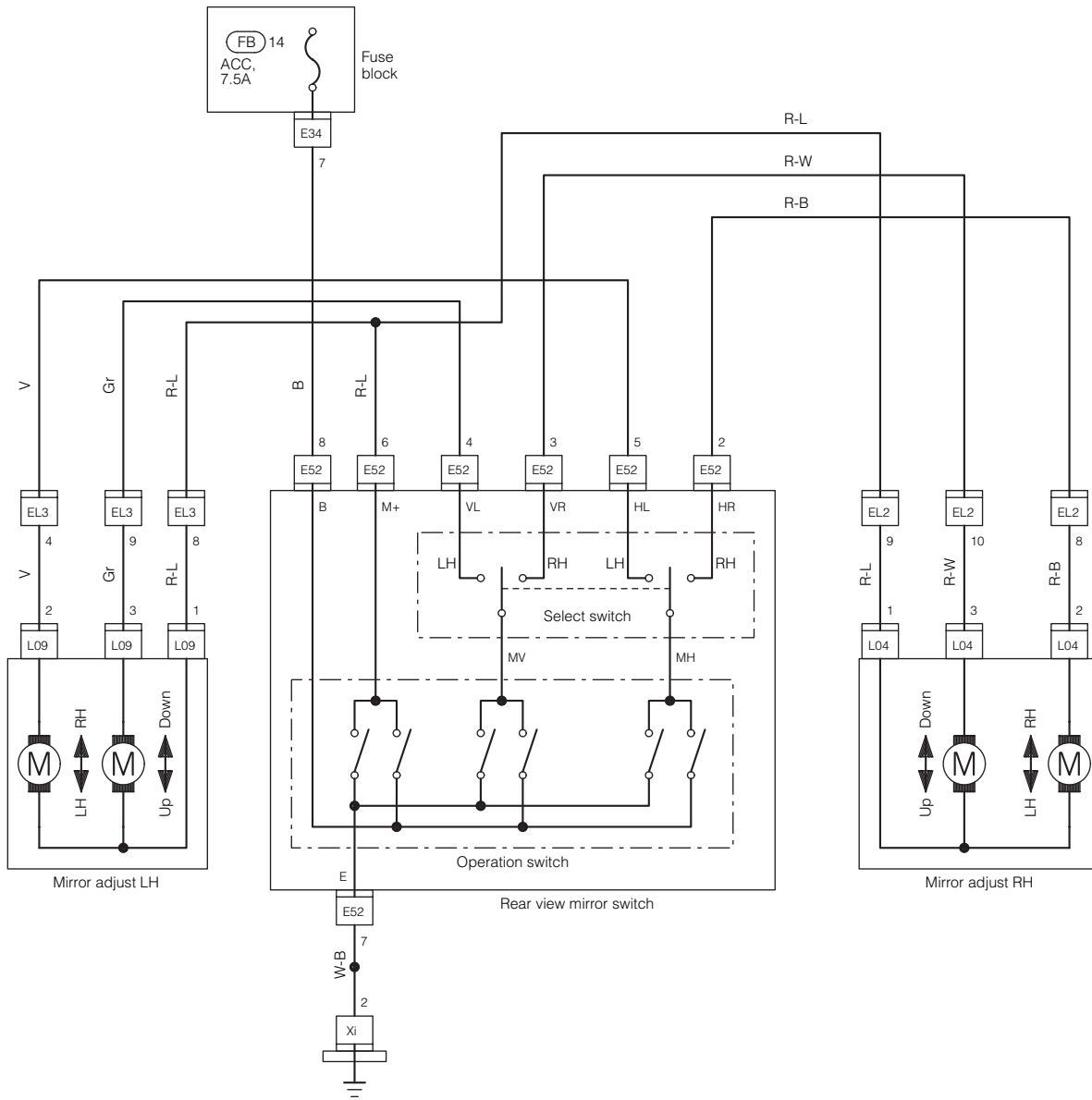

(MEMO)

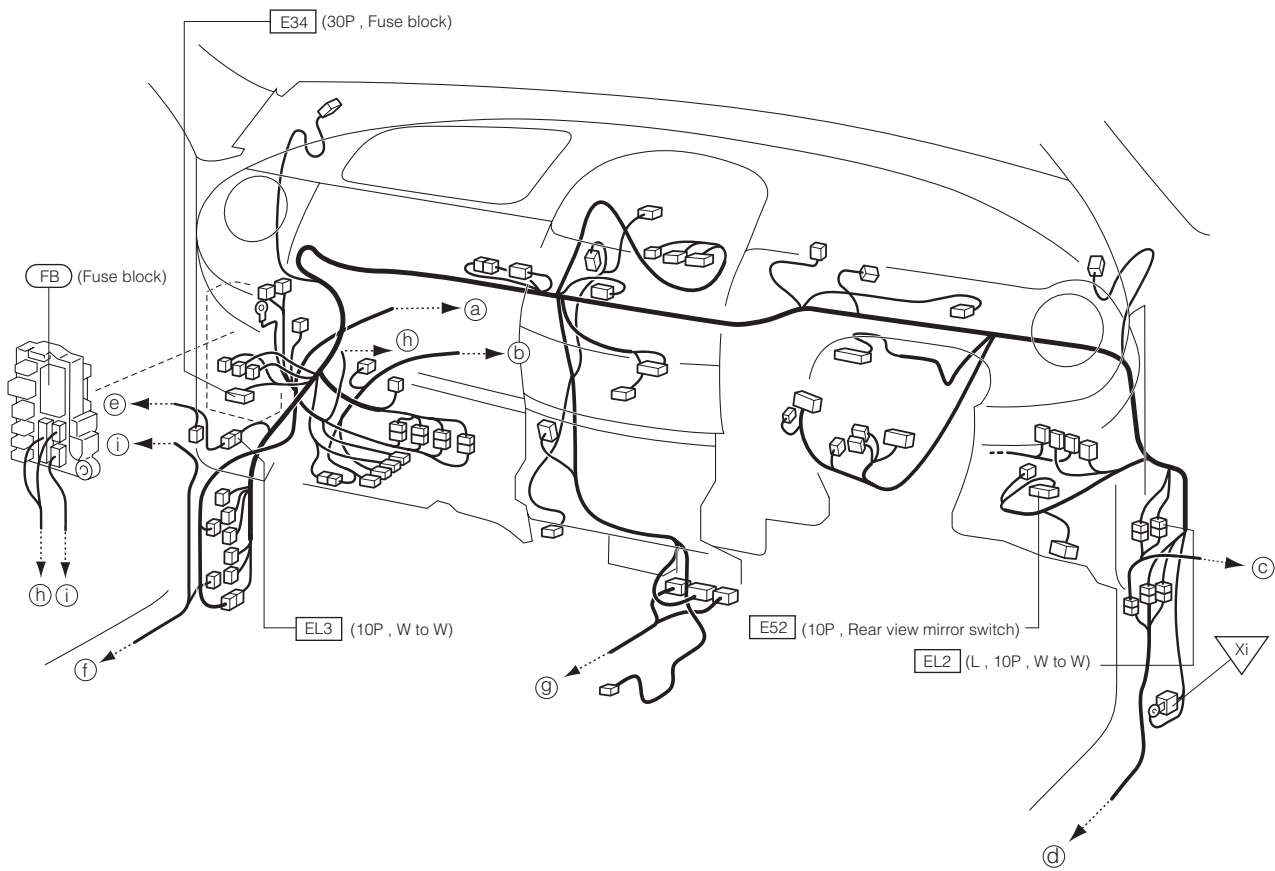

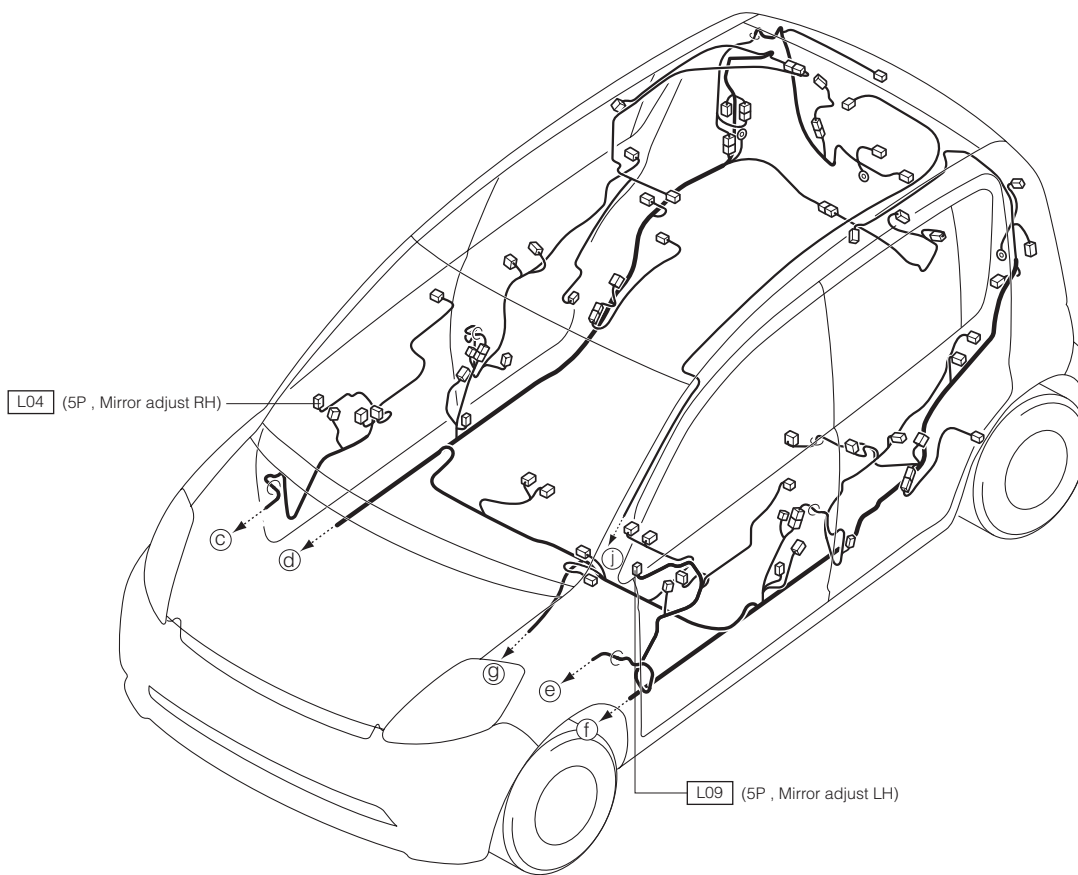

13-2 LHD VEHICLE

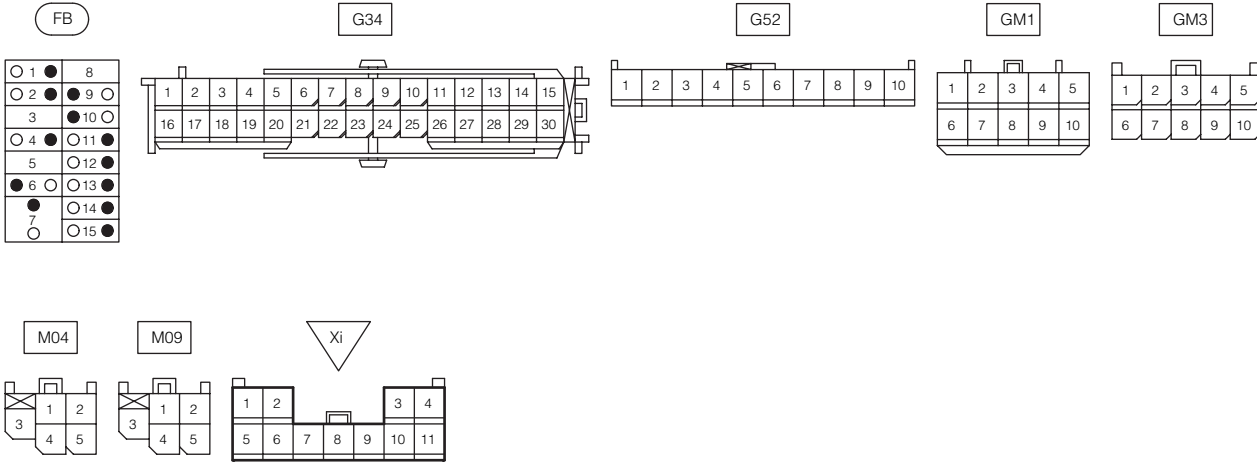
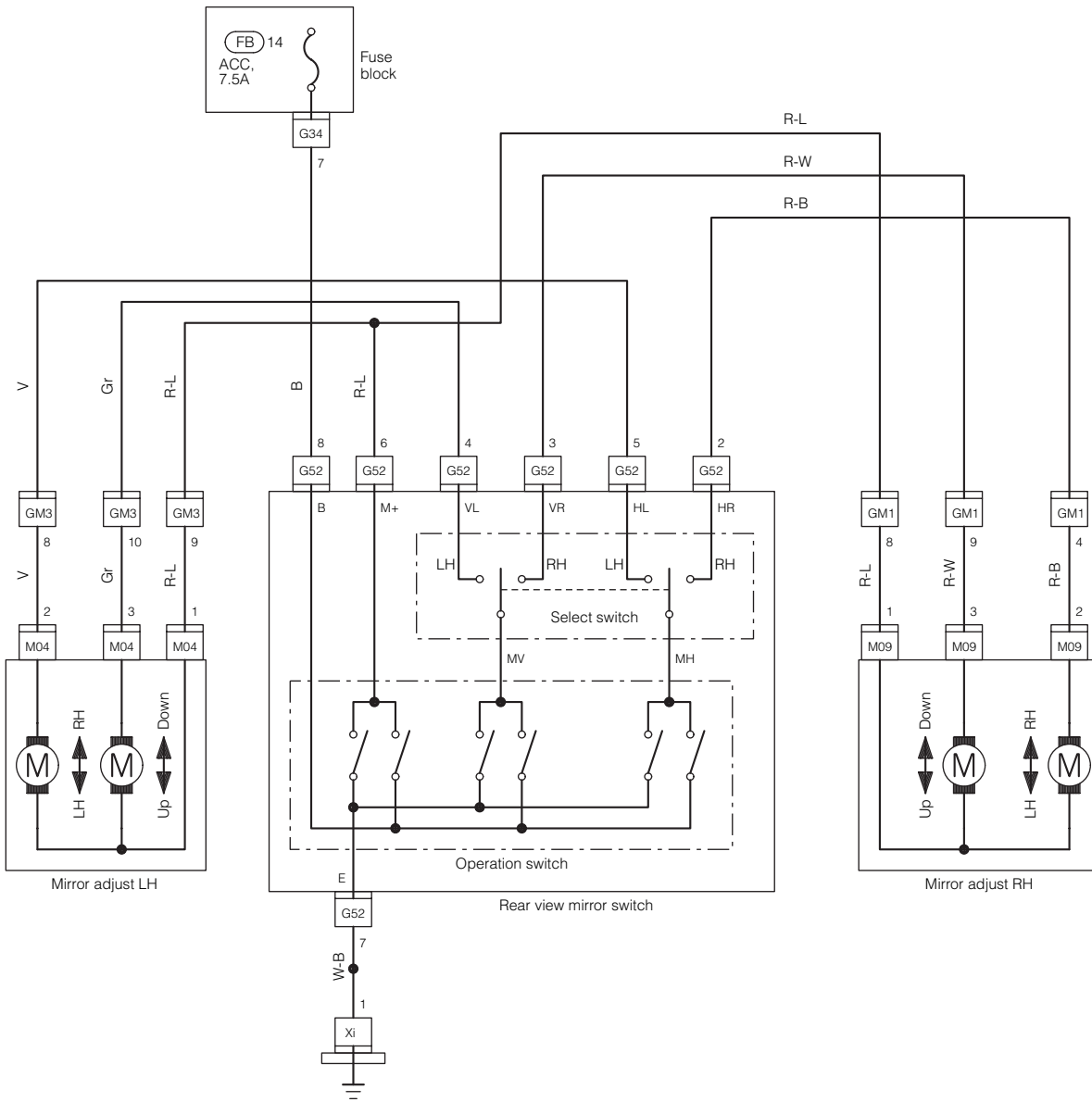

(MEMO)

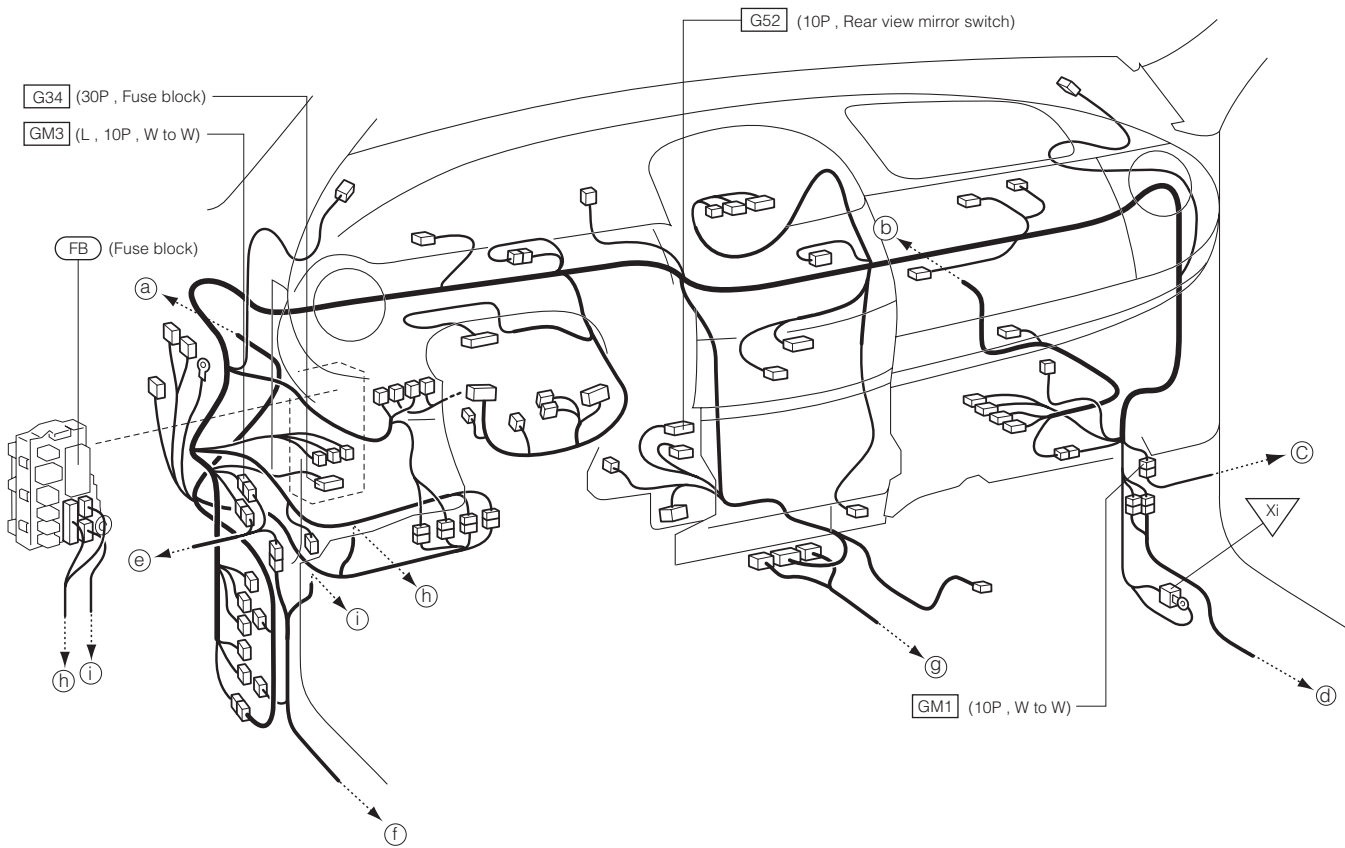

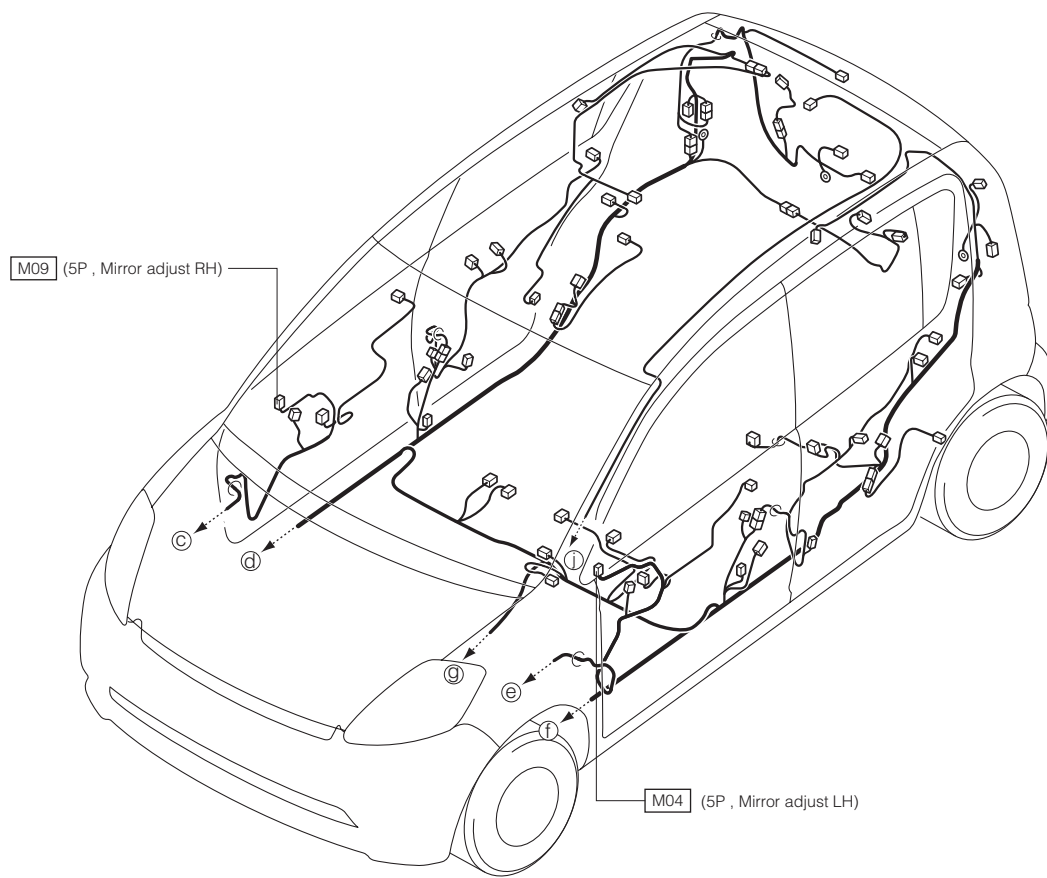

D-125

14 REAR WINDOW DEFOGGER 14-1 RHD VEHICLE

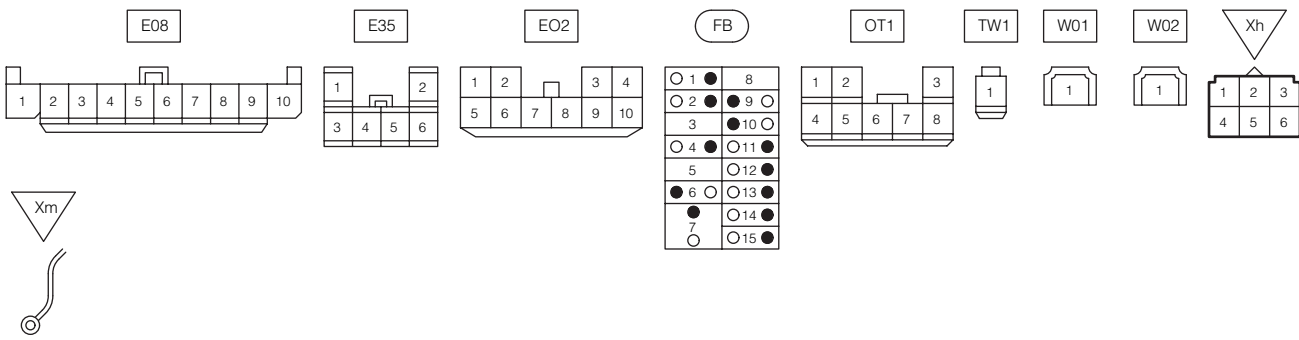
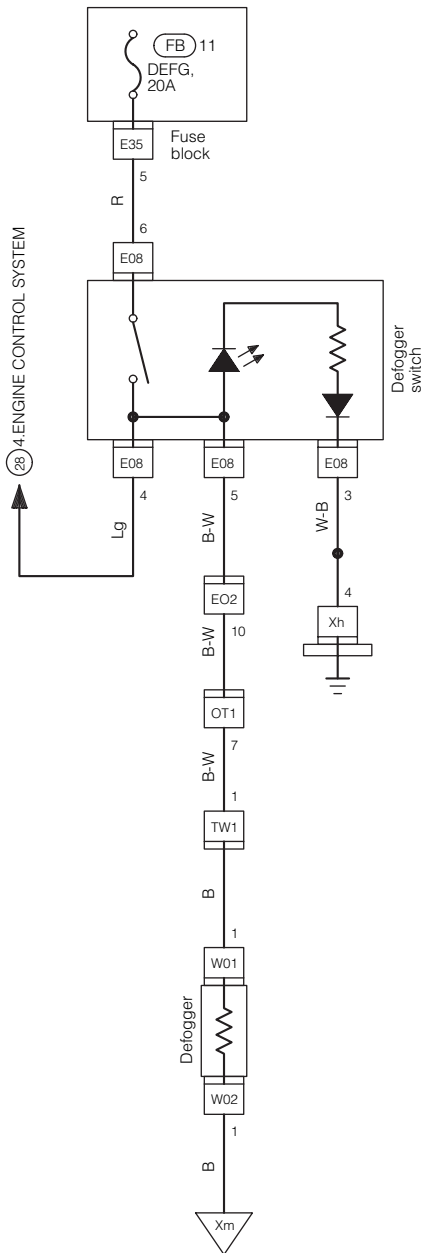

(MEMO)

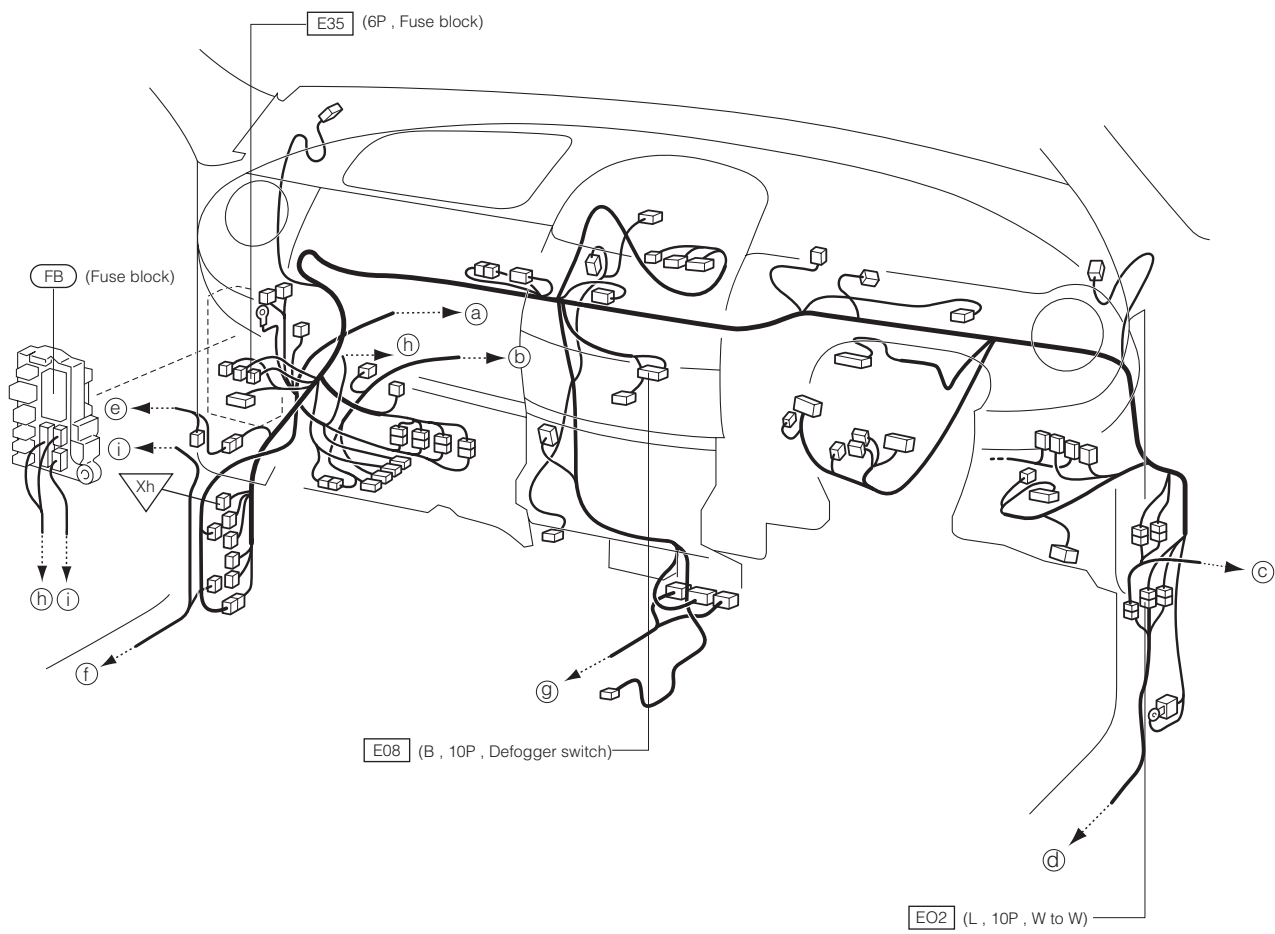

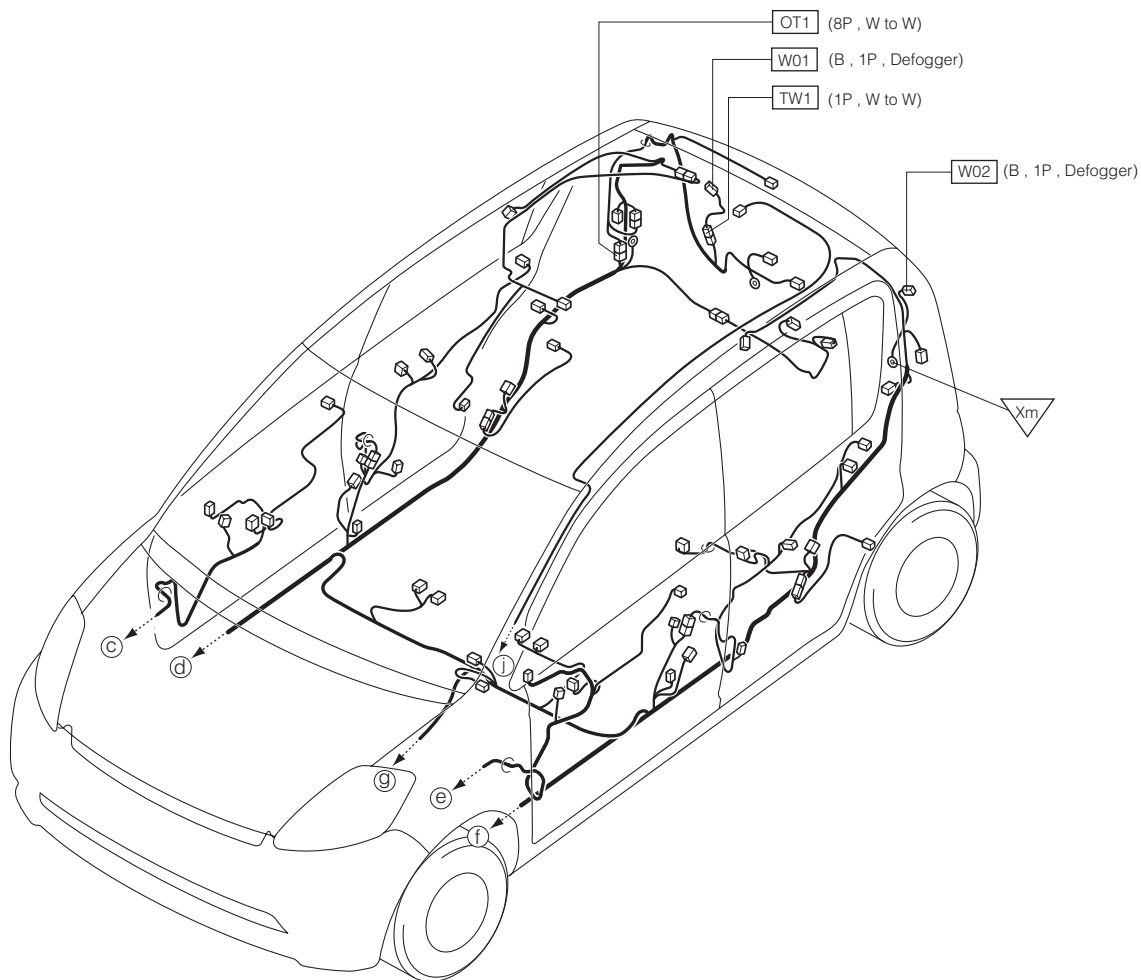

14-2 LHD VEHICLE

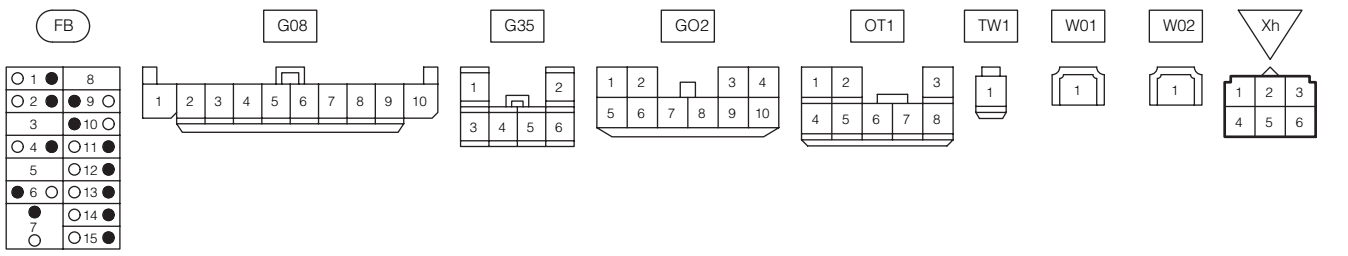
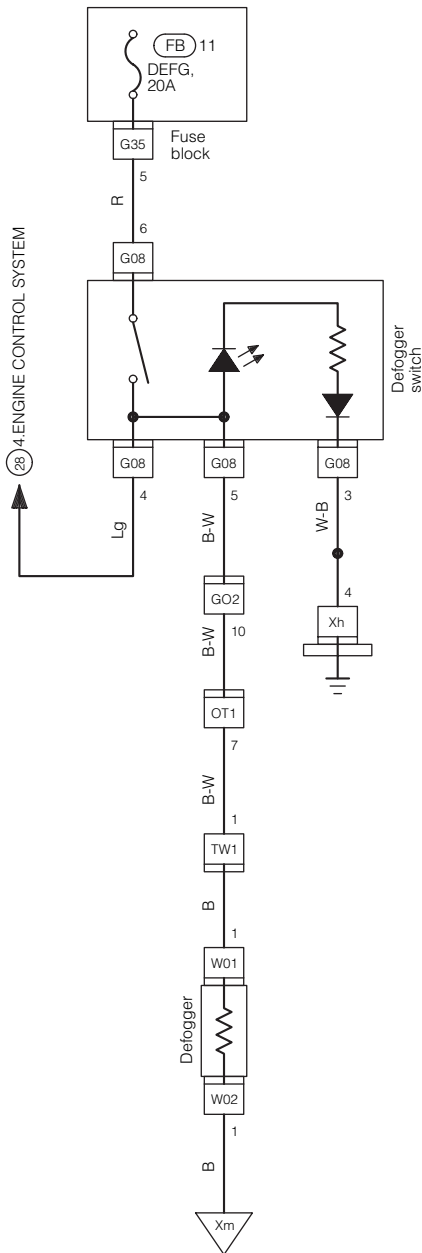

(MEMO)

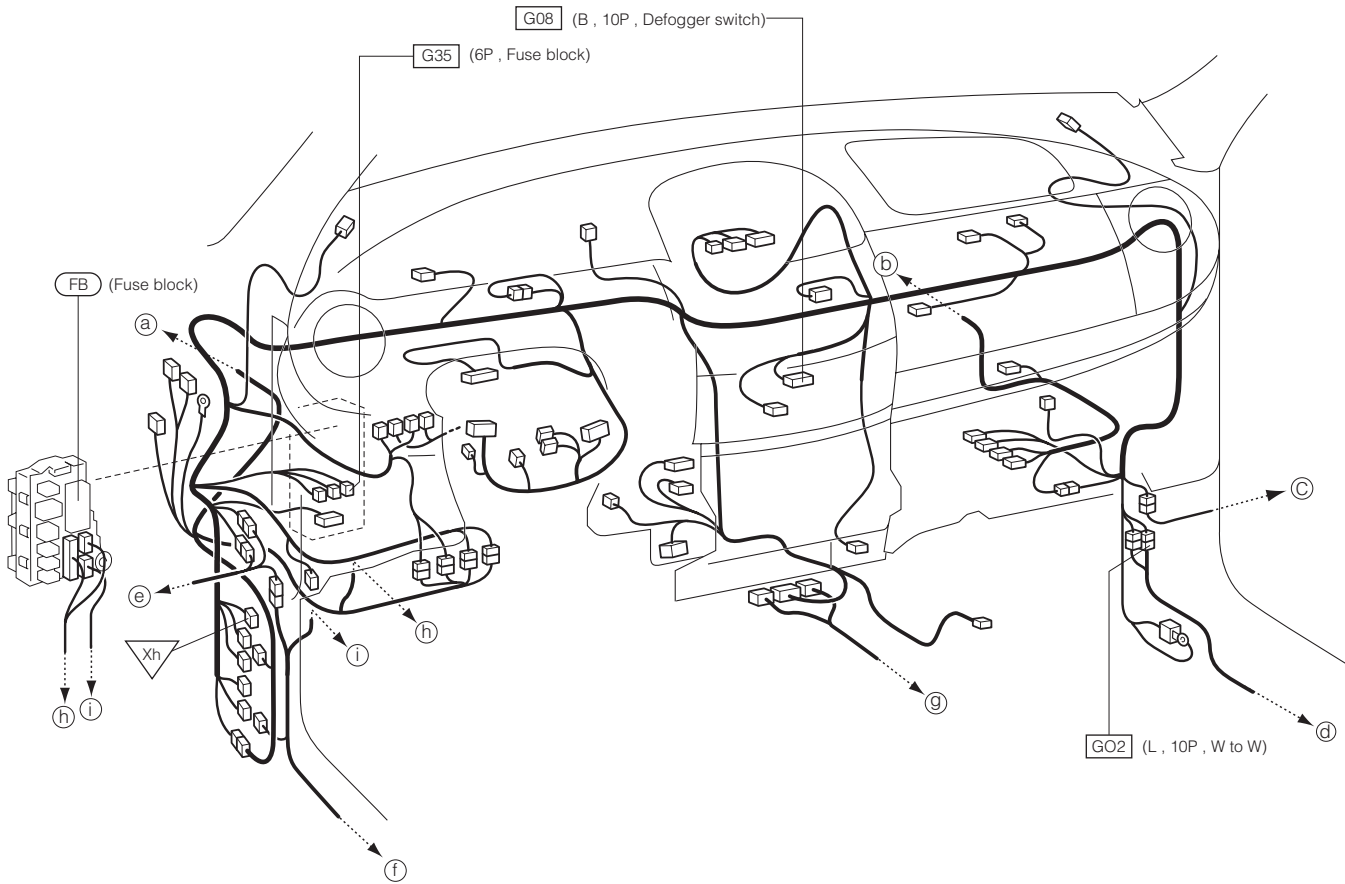

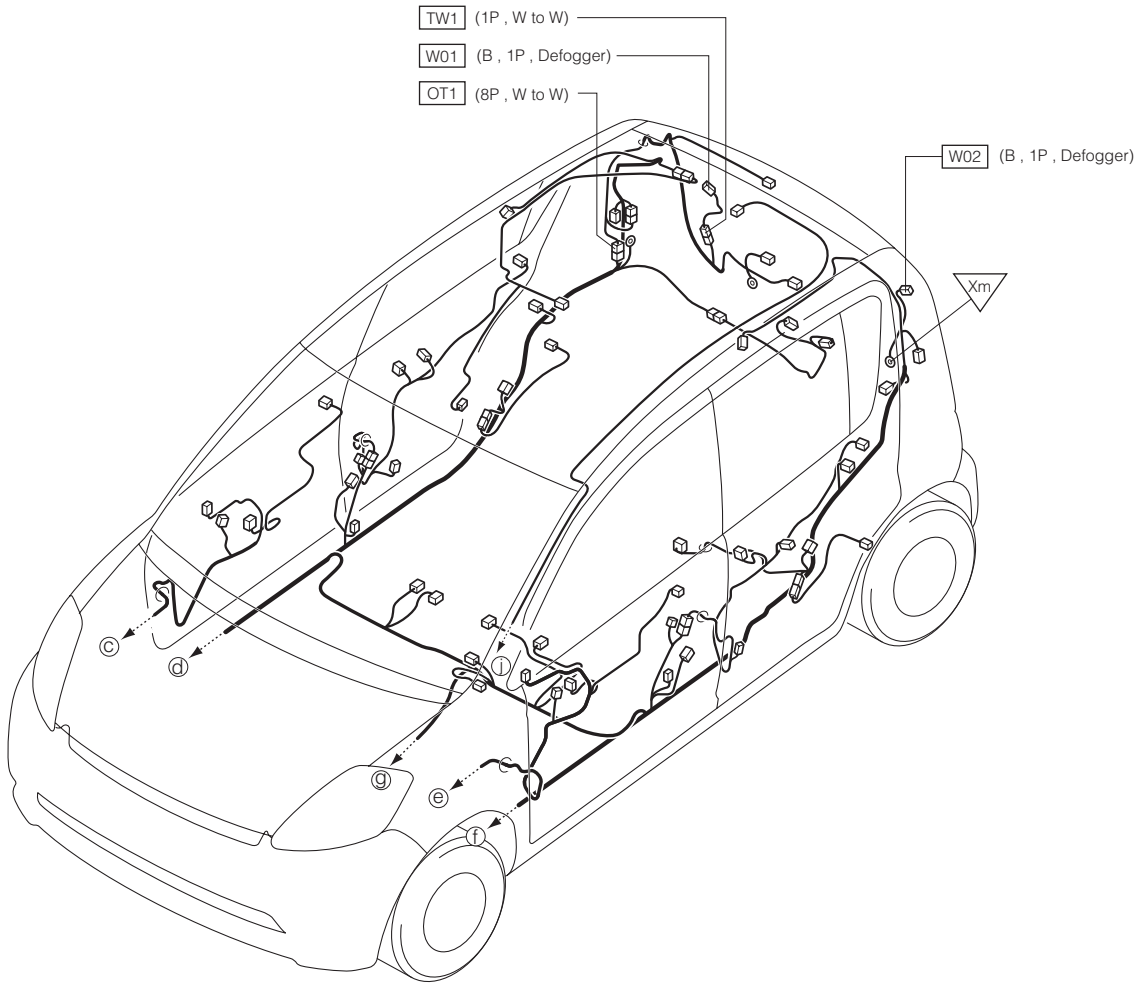

D-133

15 POWER WINDOW 15-1 RHD VEHICLE

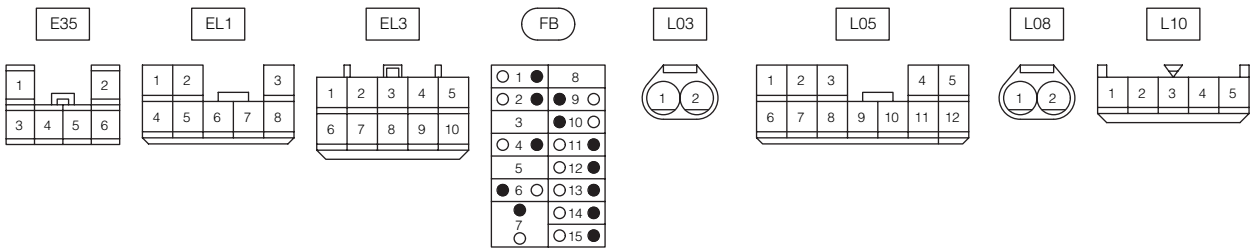
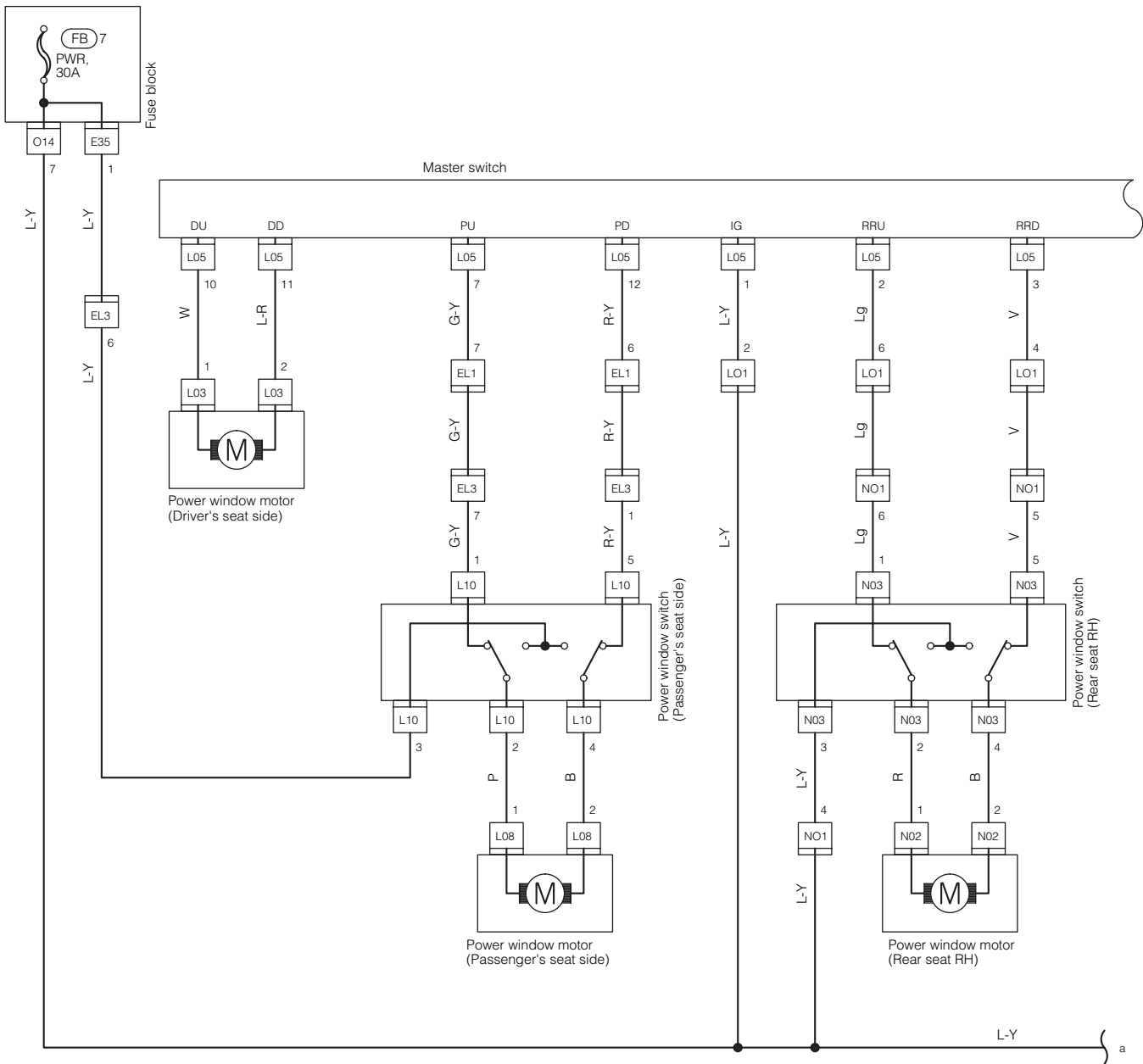

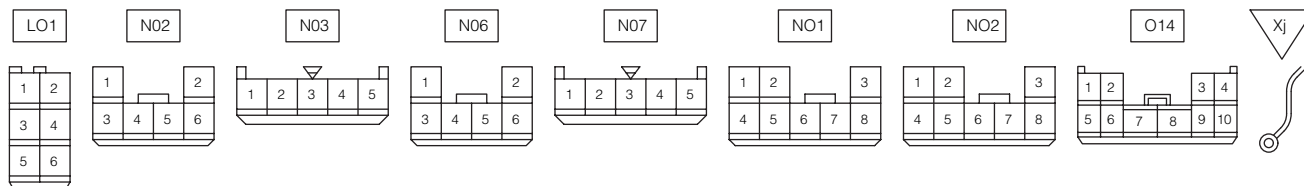
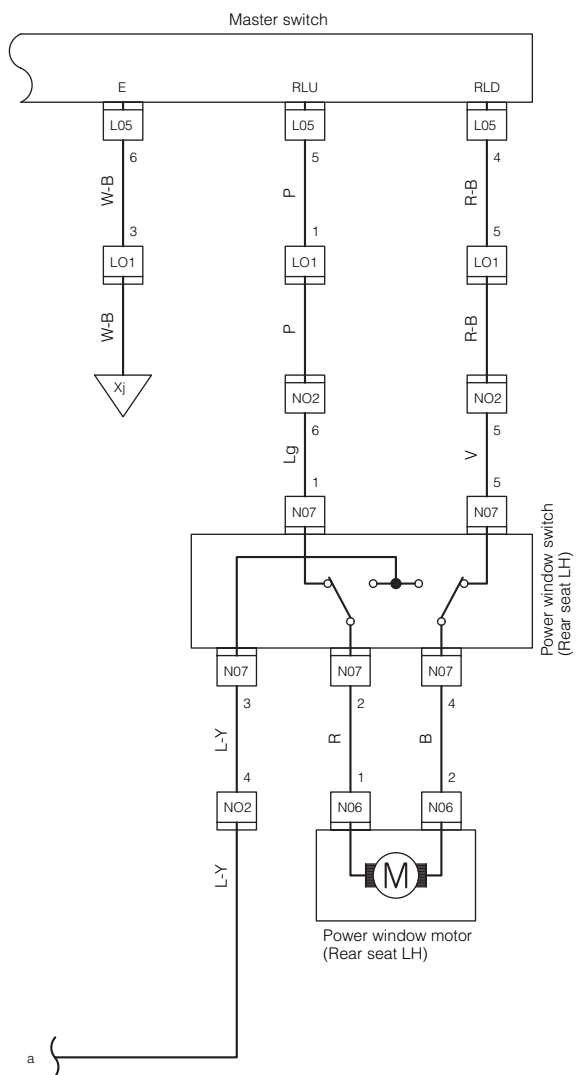

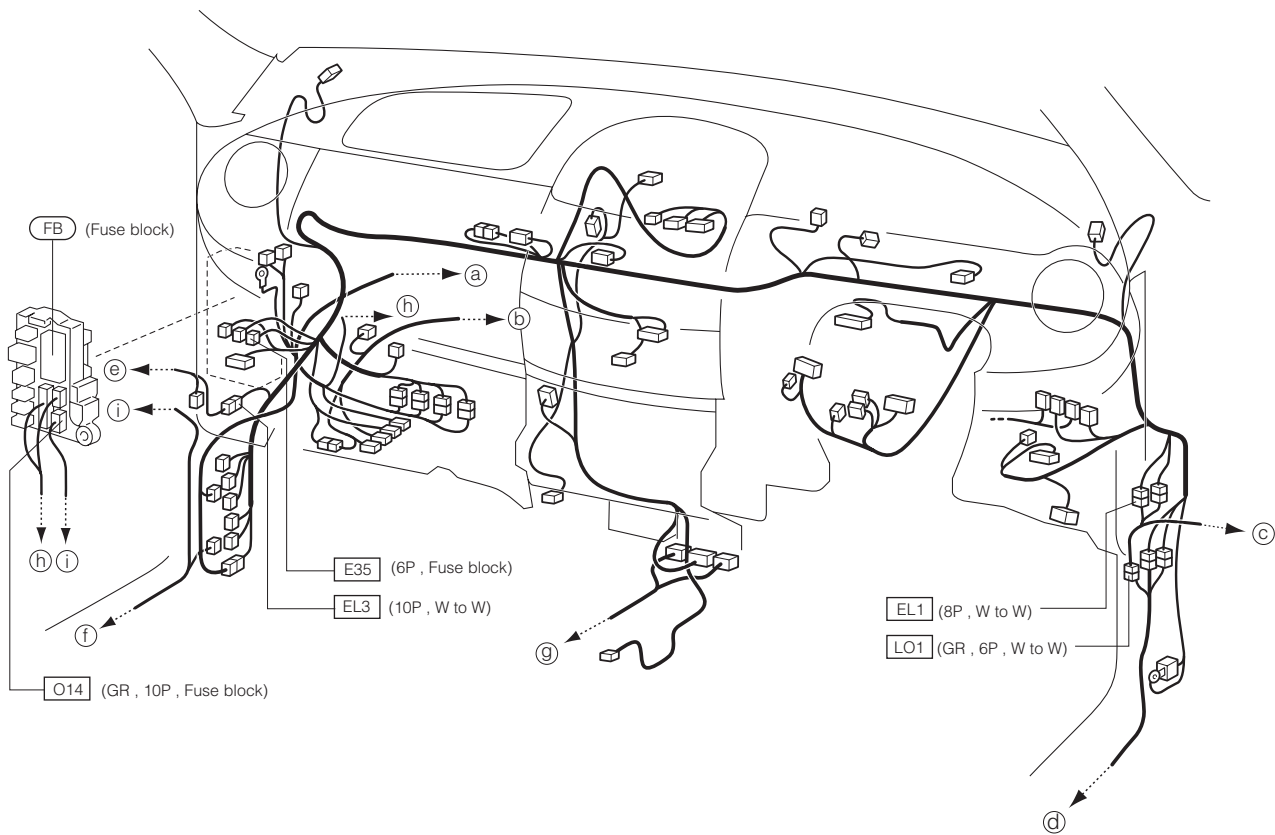

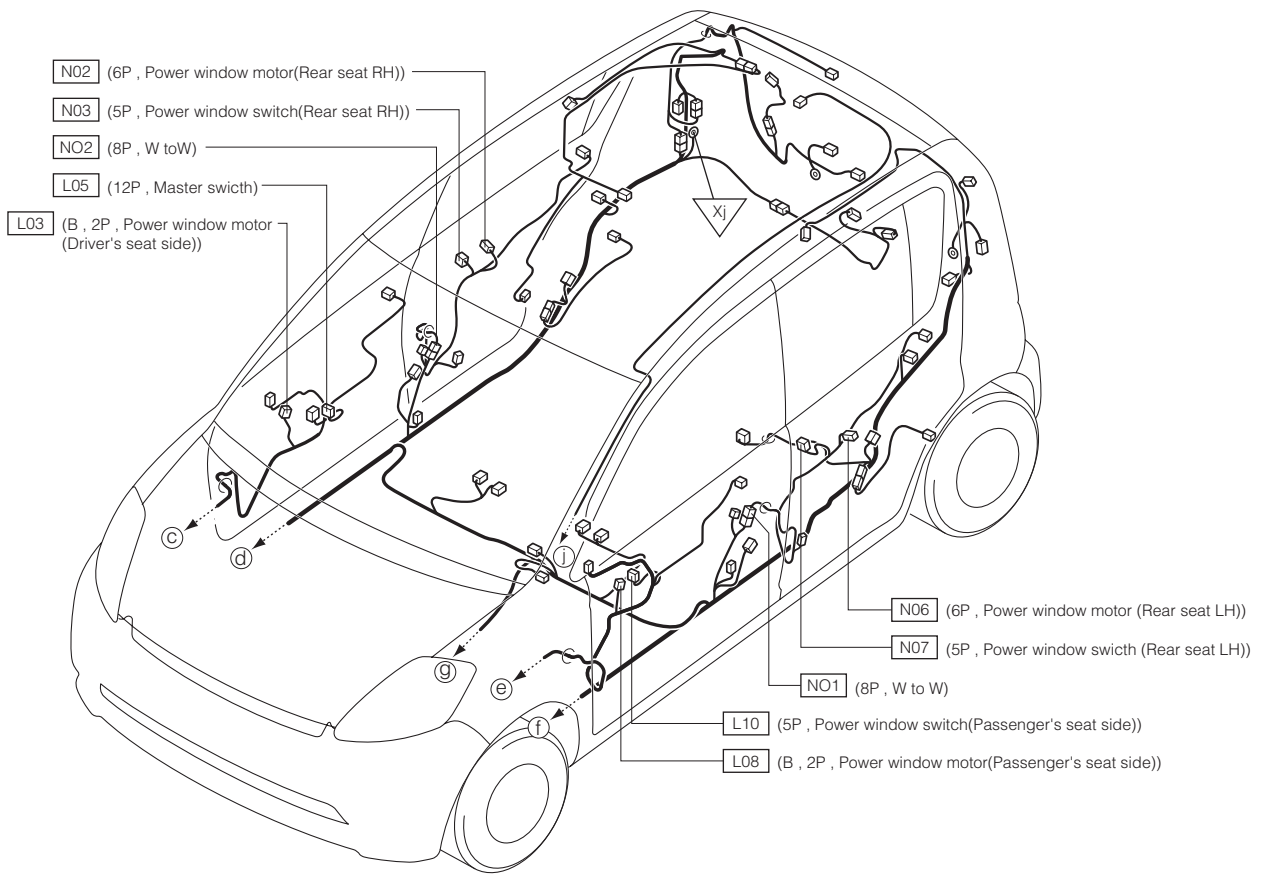

15-2 LHD VEHICLE

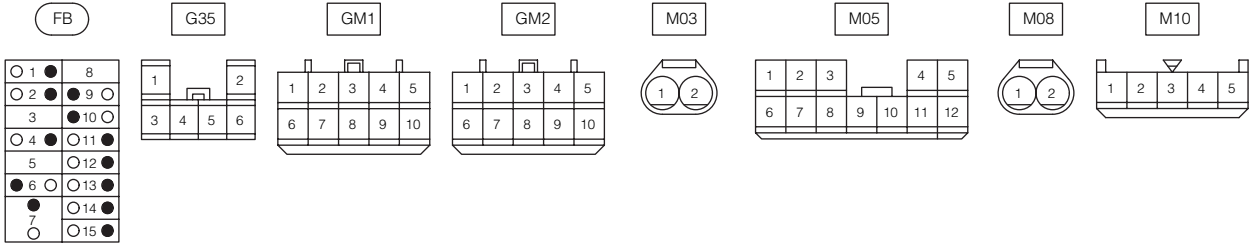
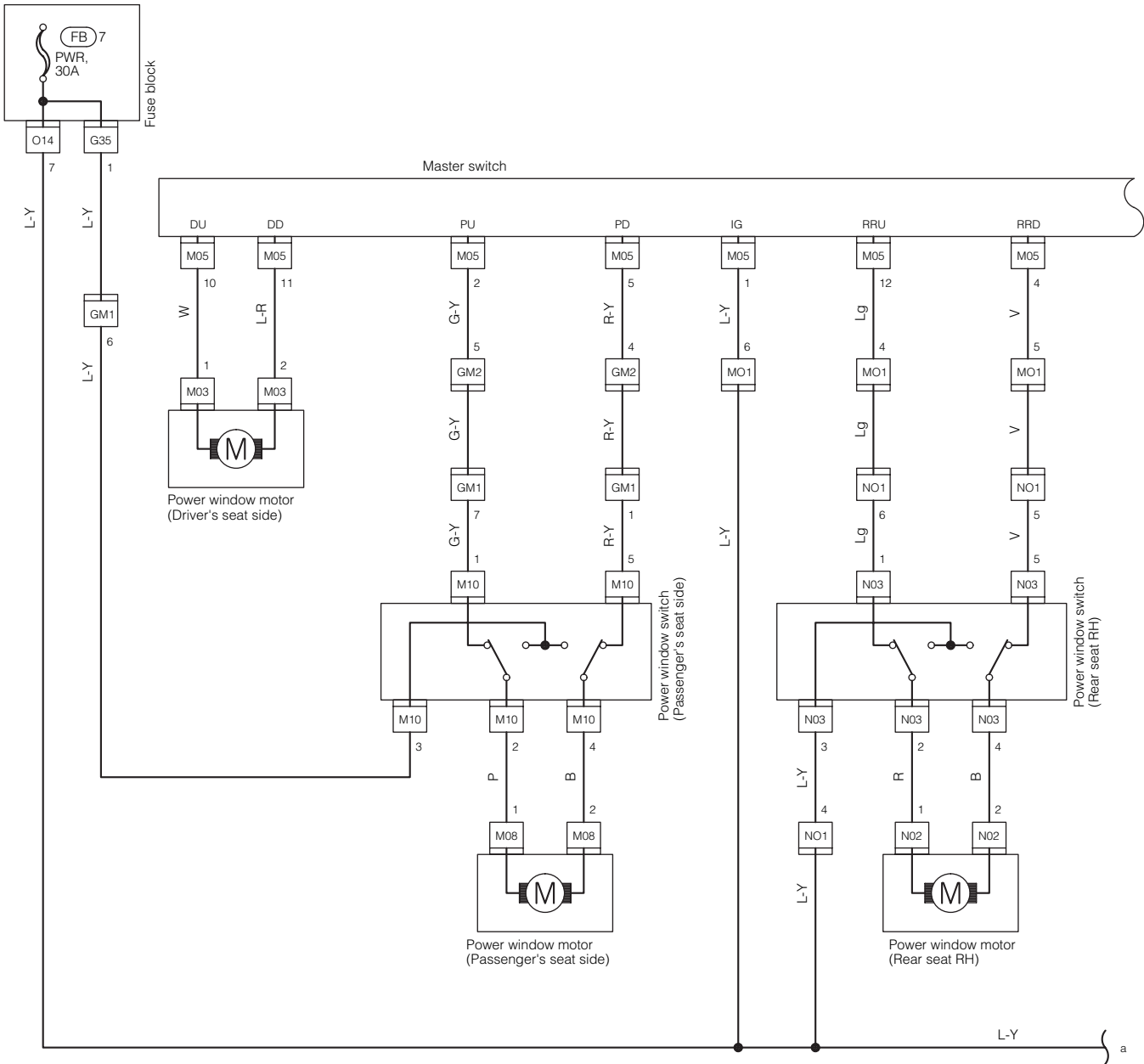

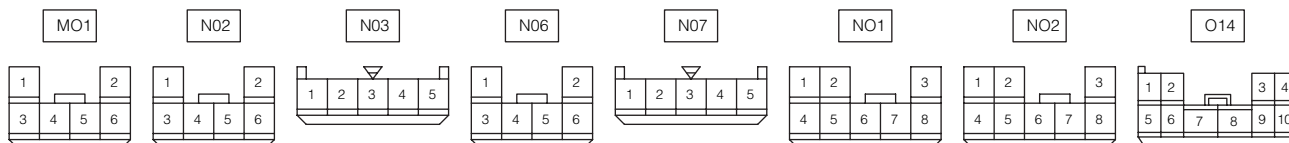
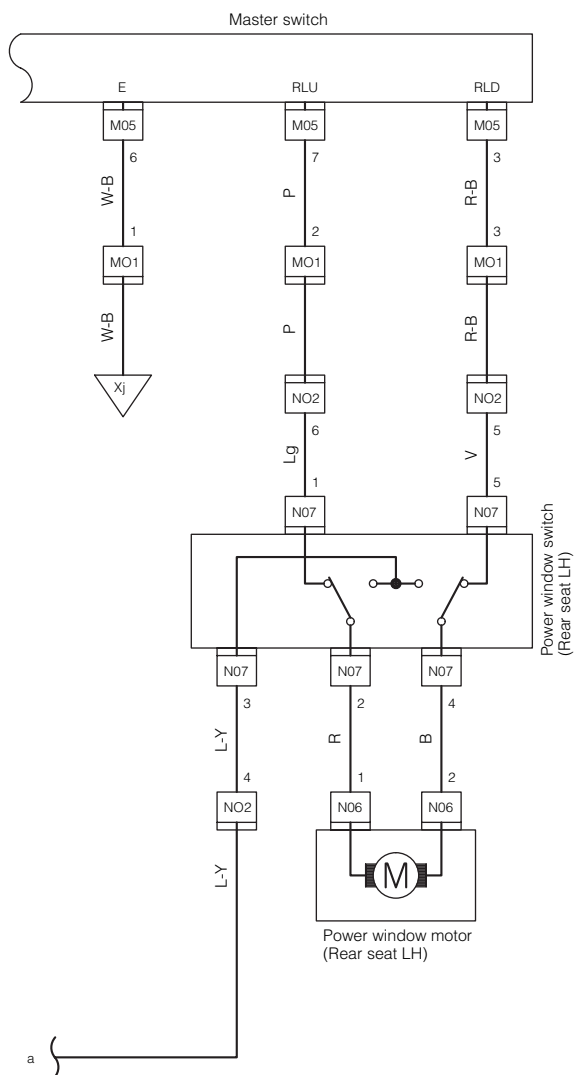

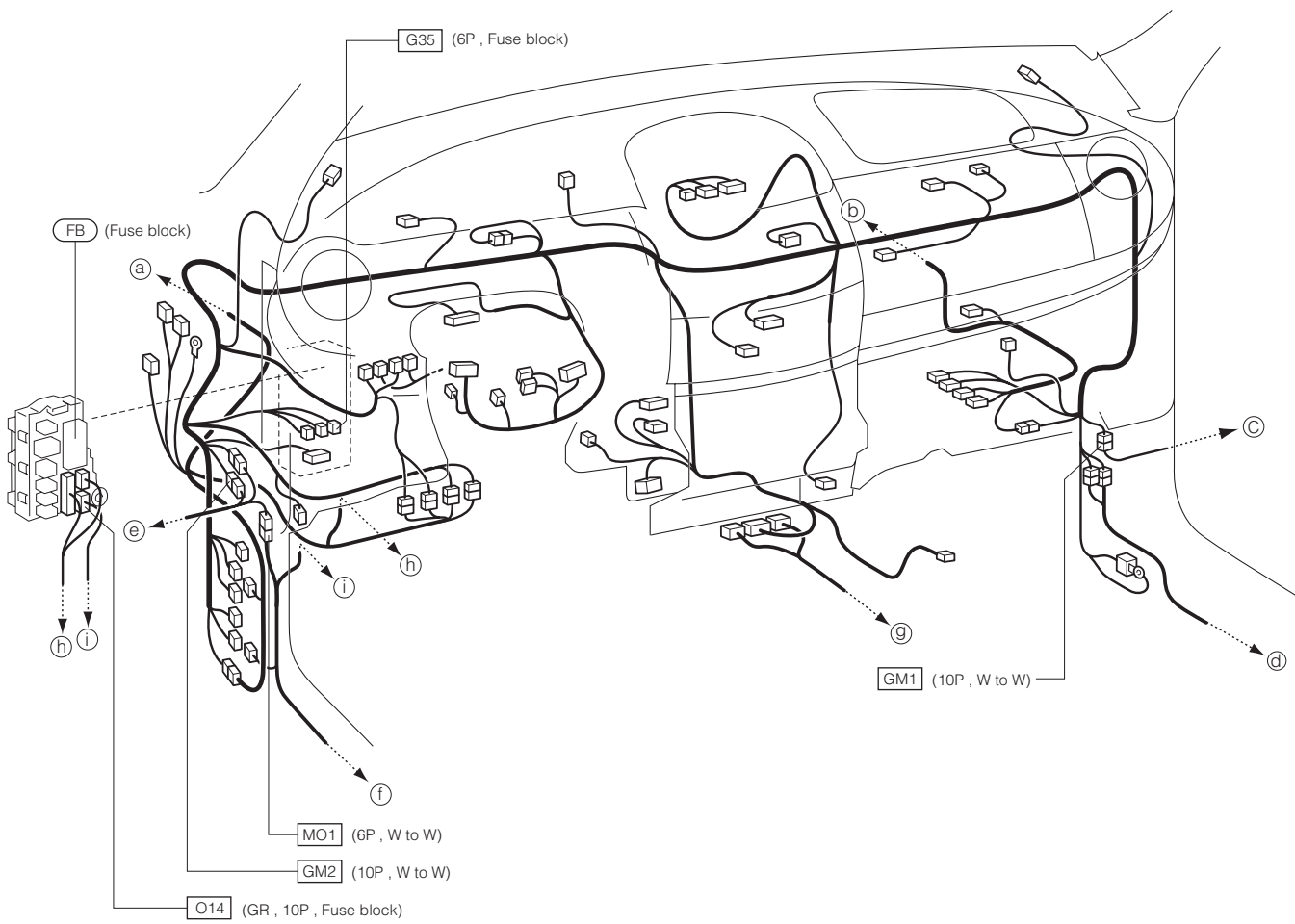

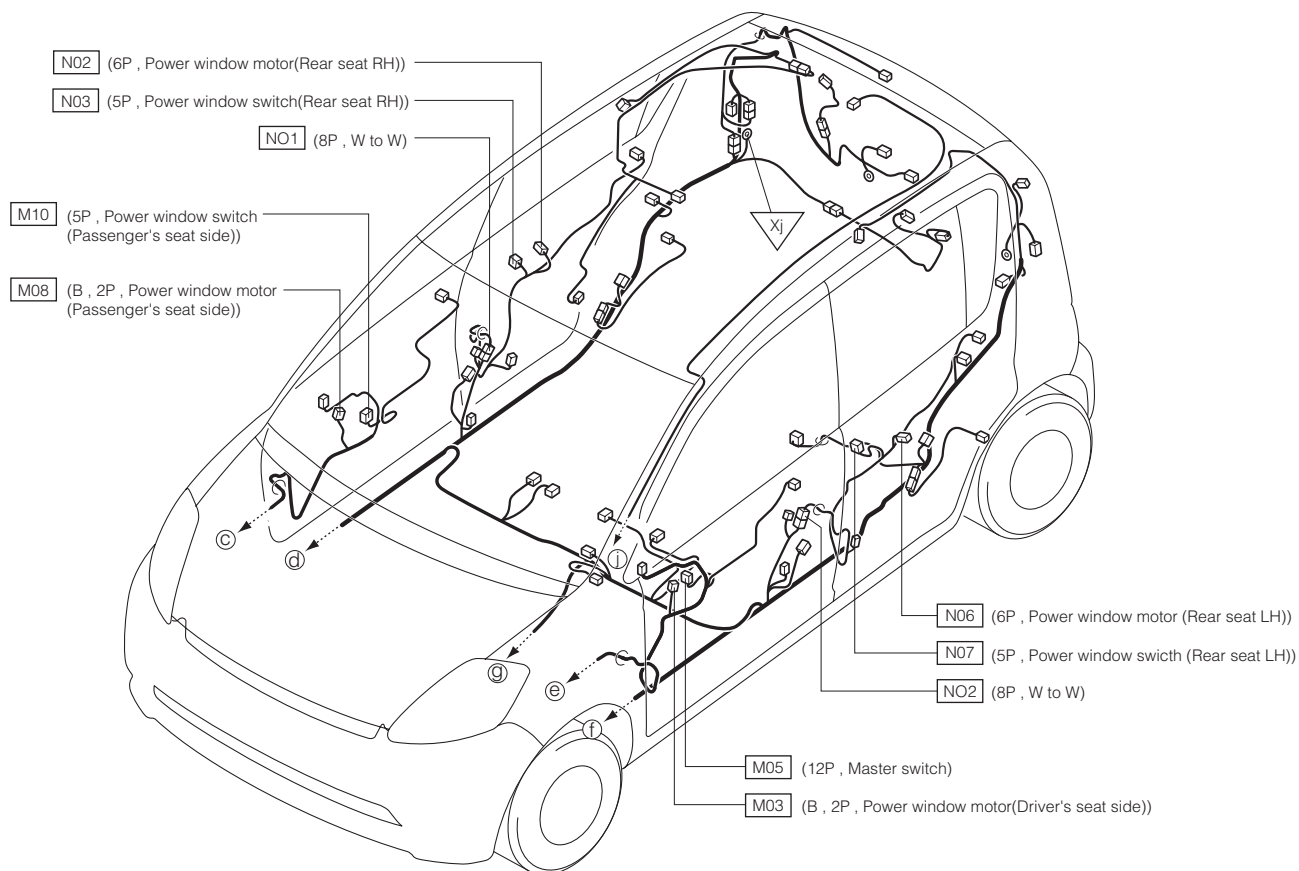

16 METER 16-1 RHD VEHICLE

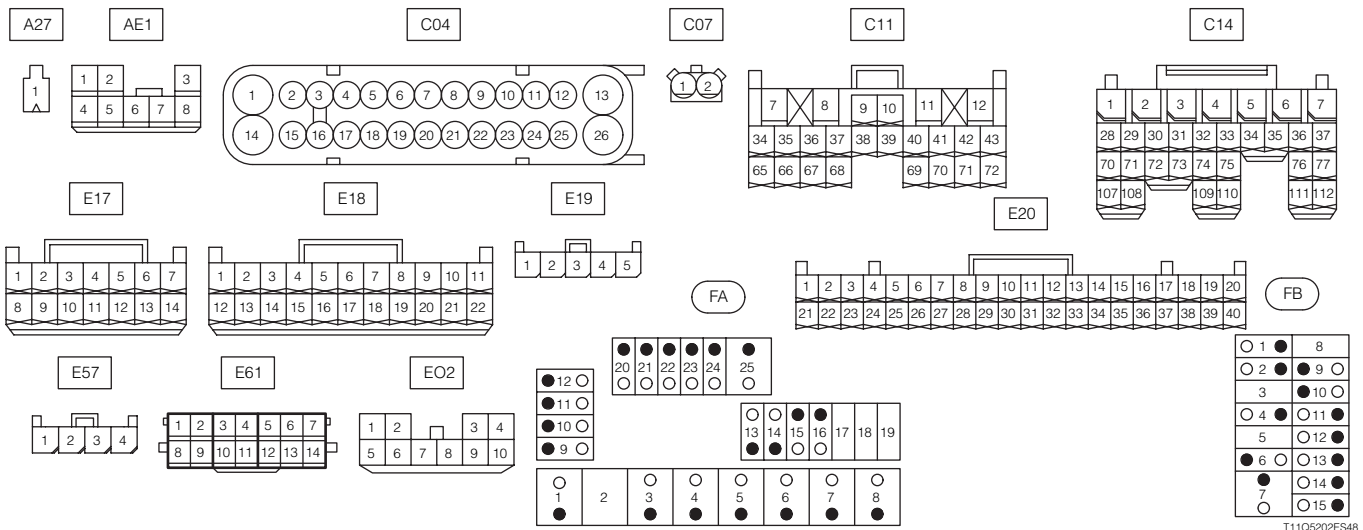
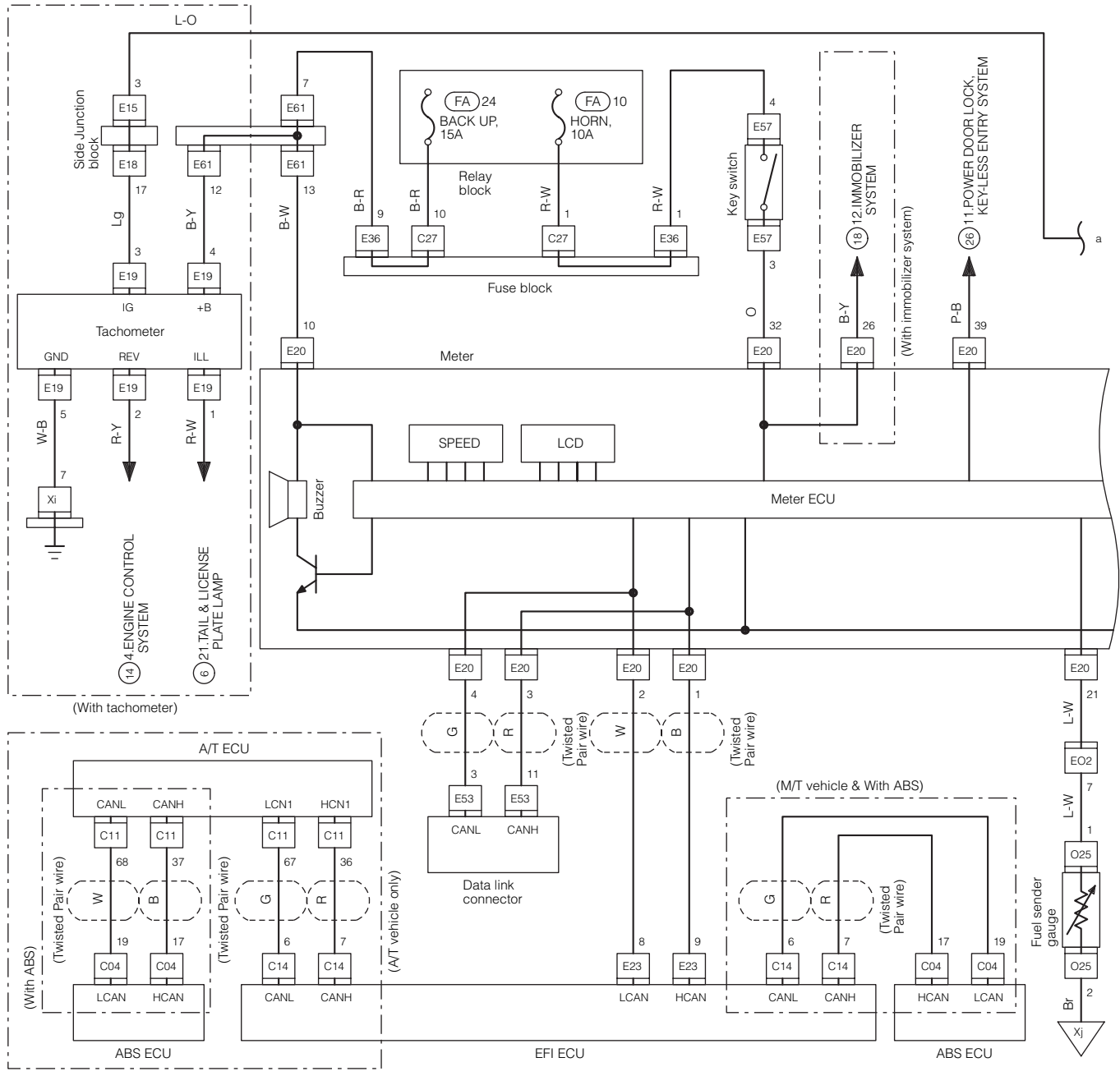

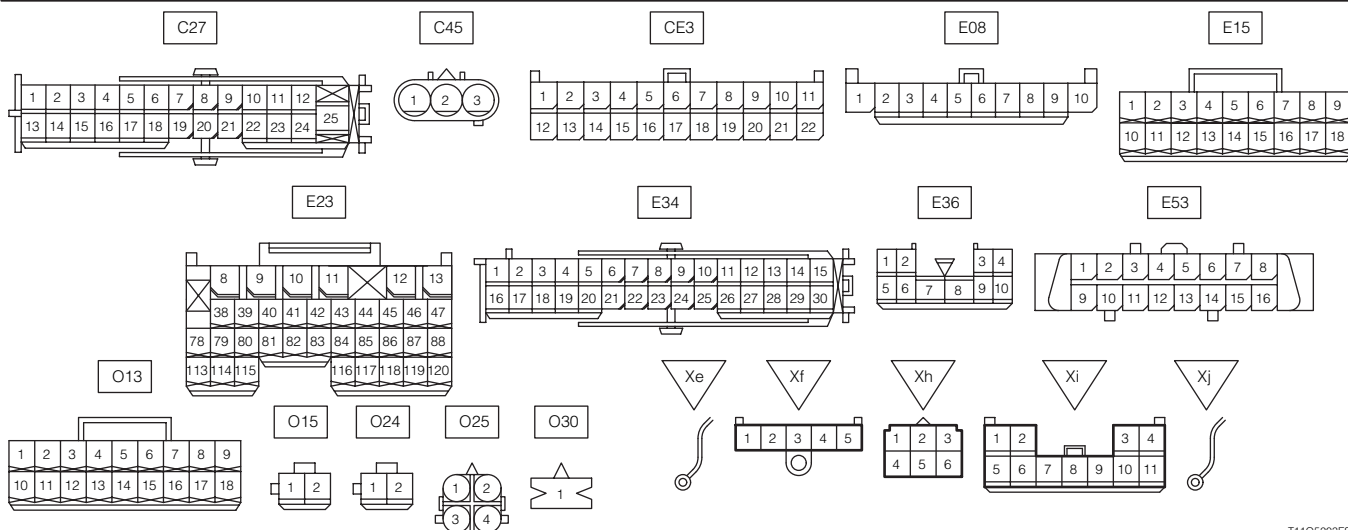
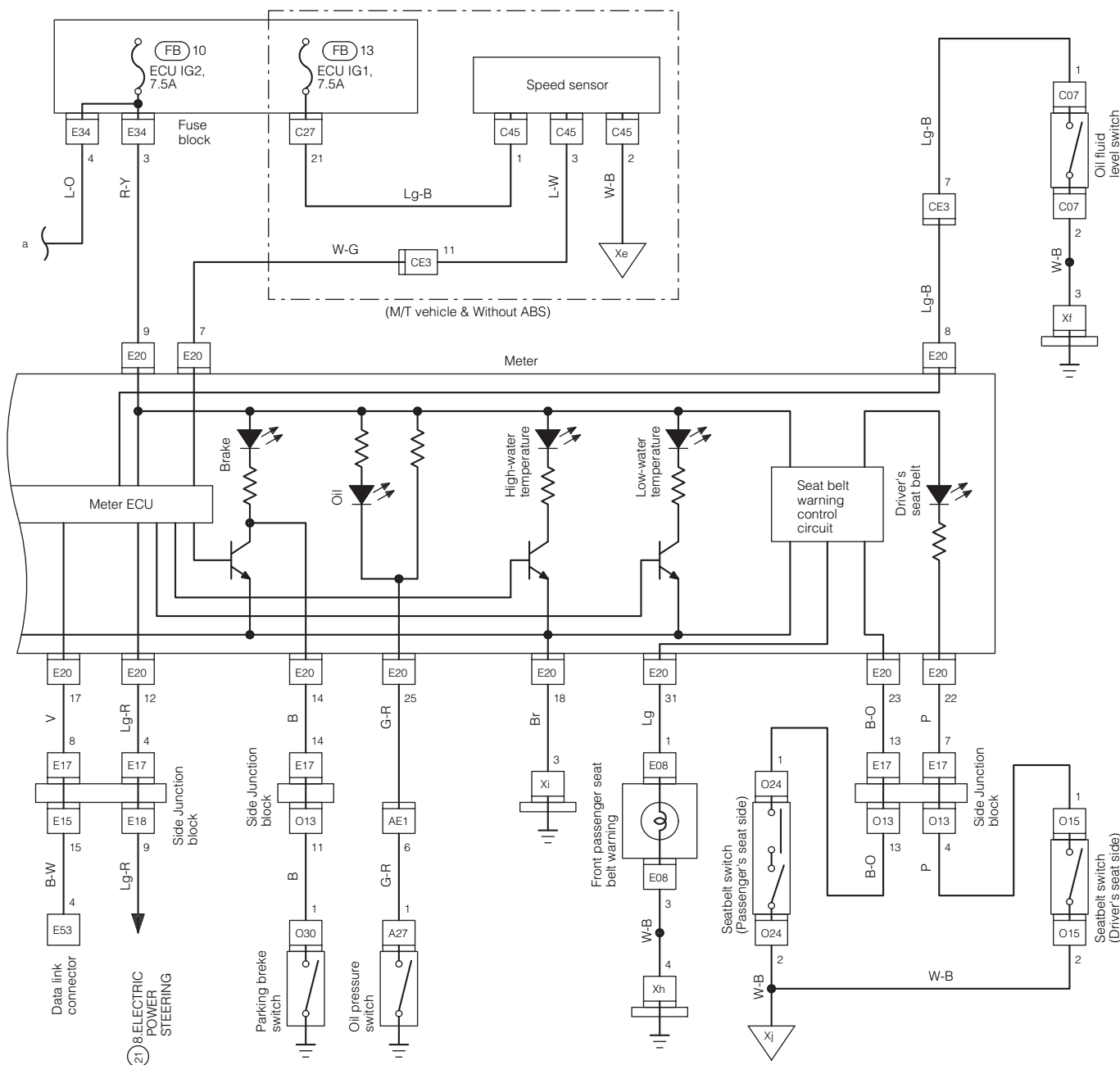

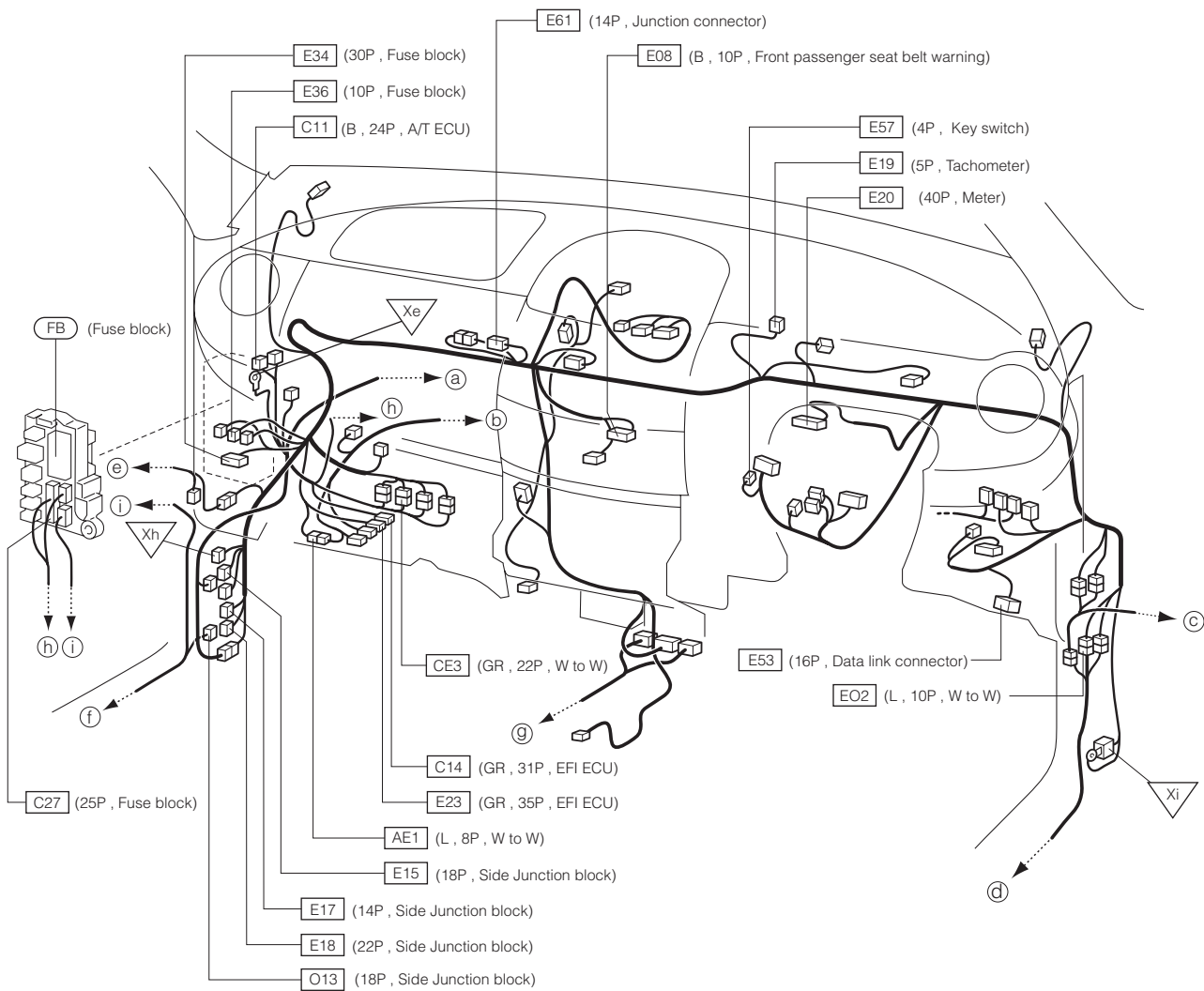

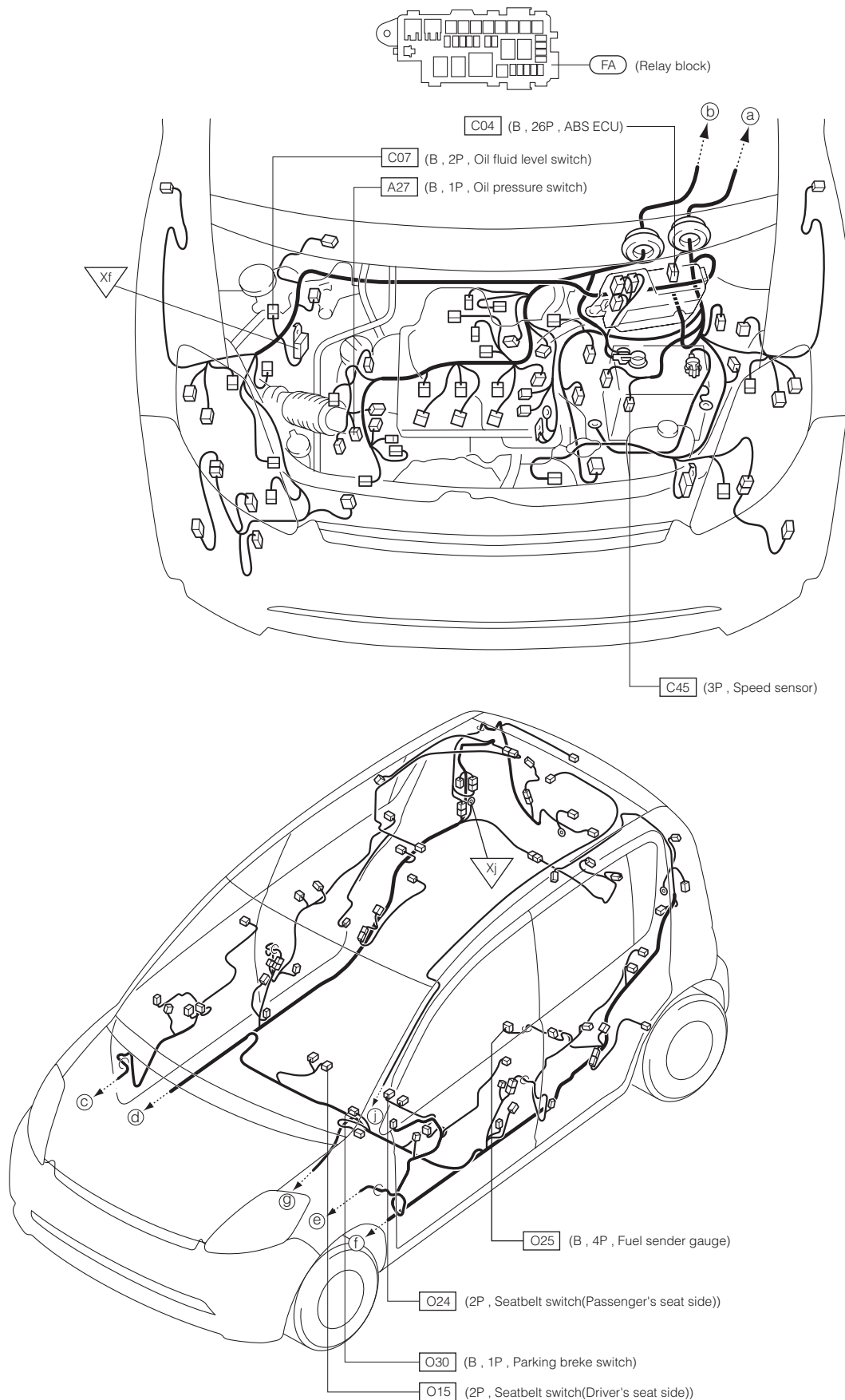

16-2 LHD VEHICLE

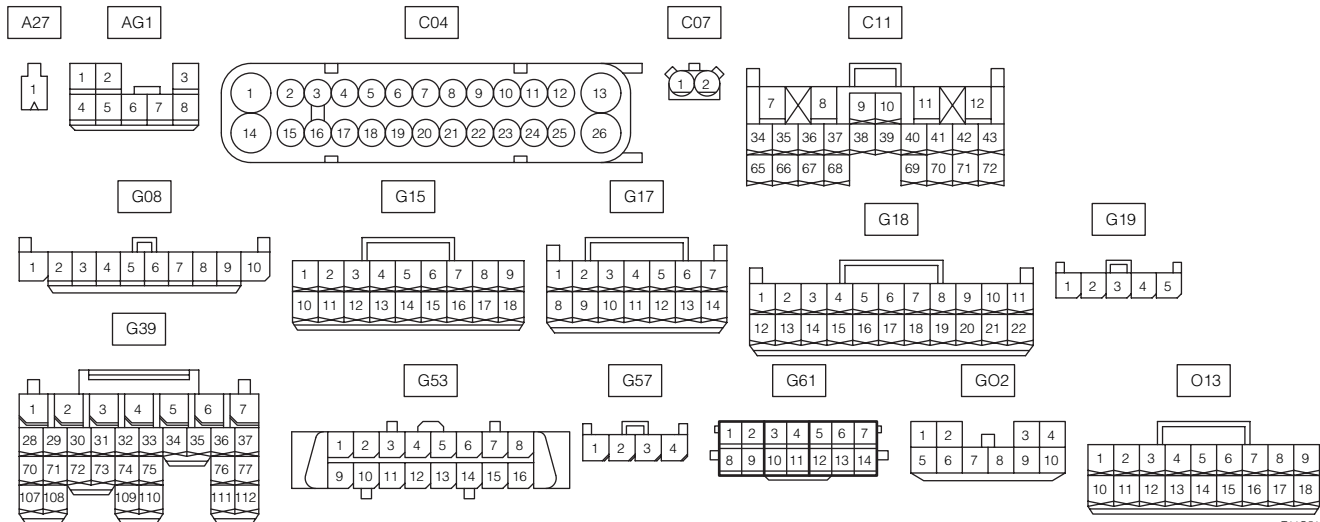
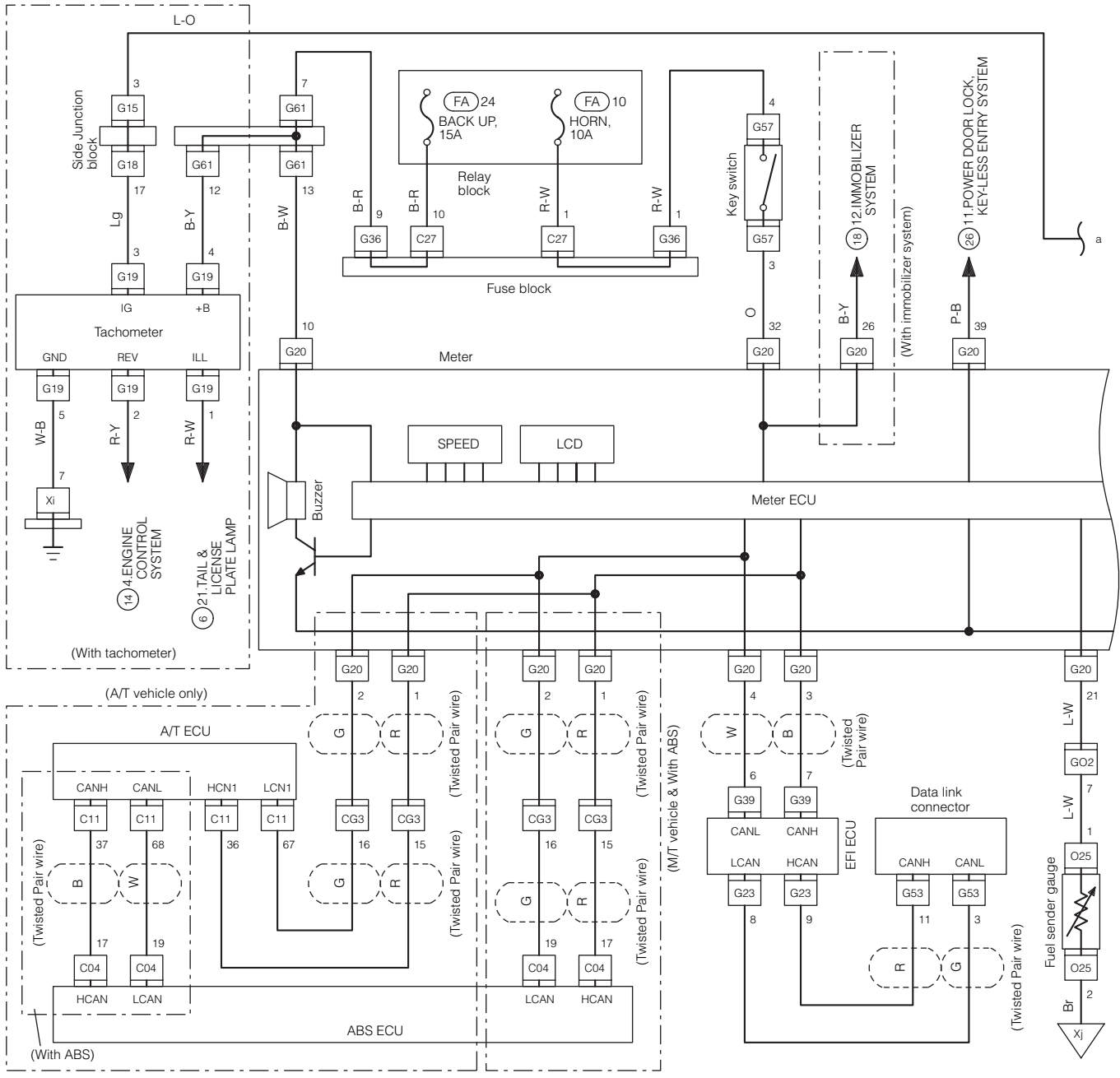

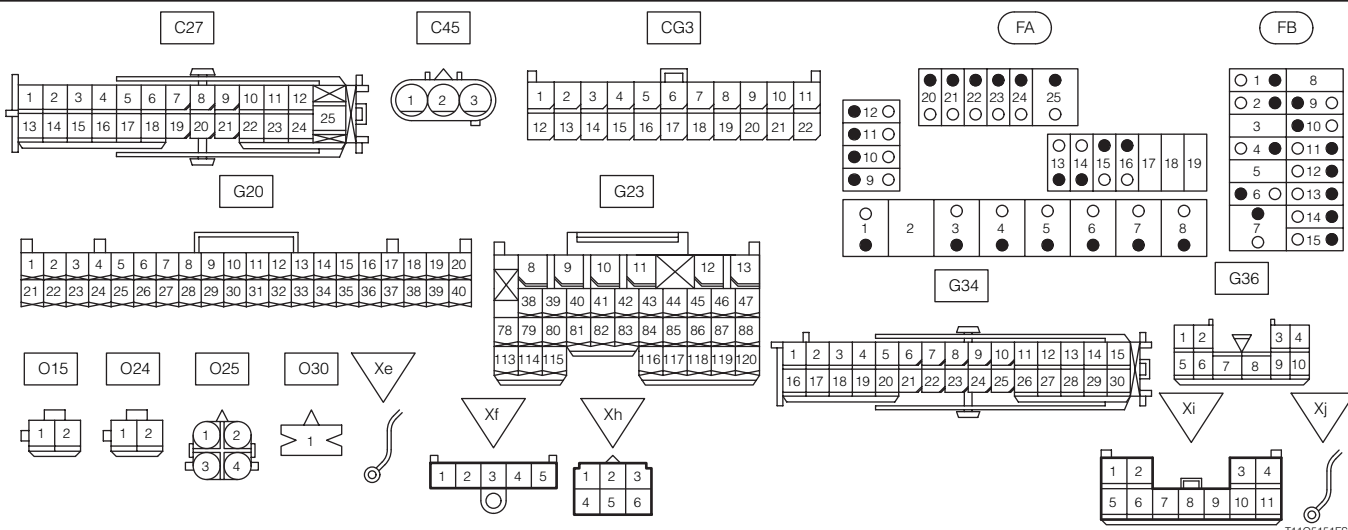
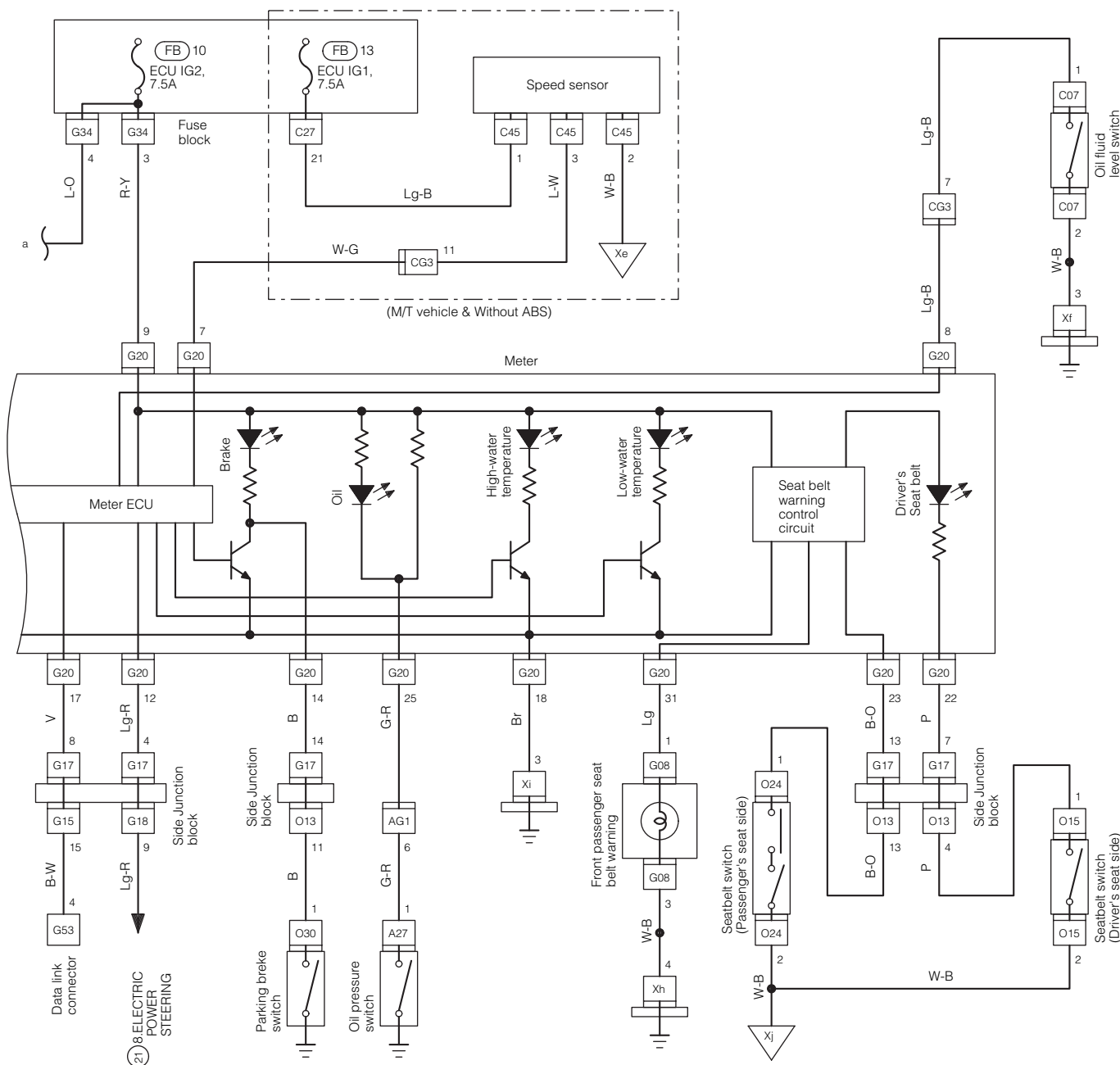

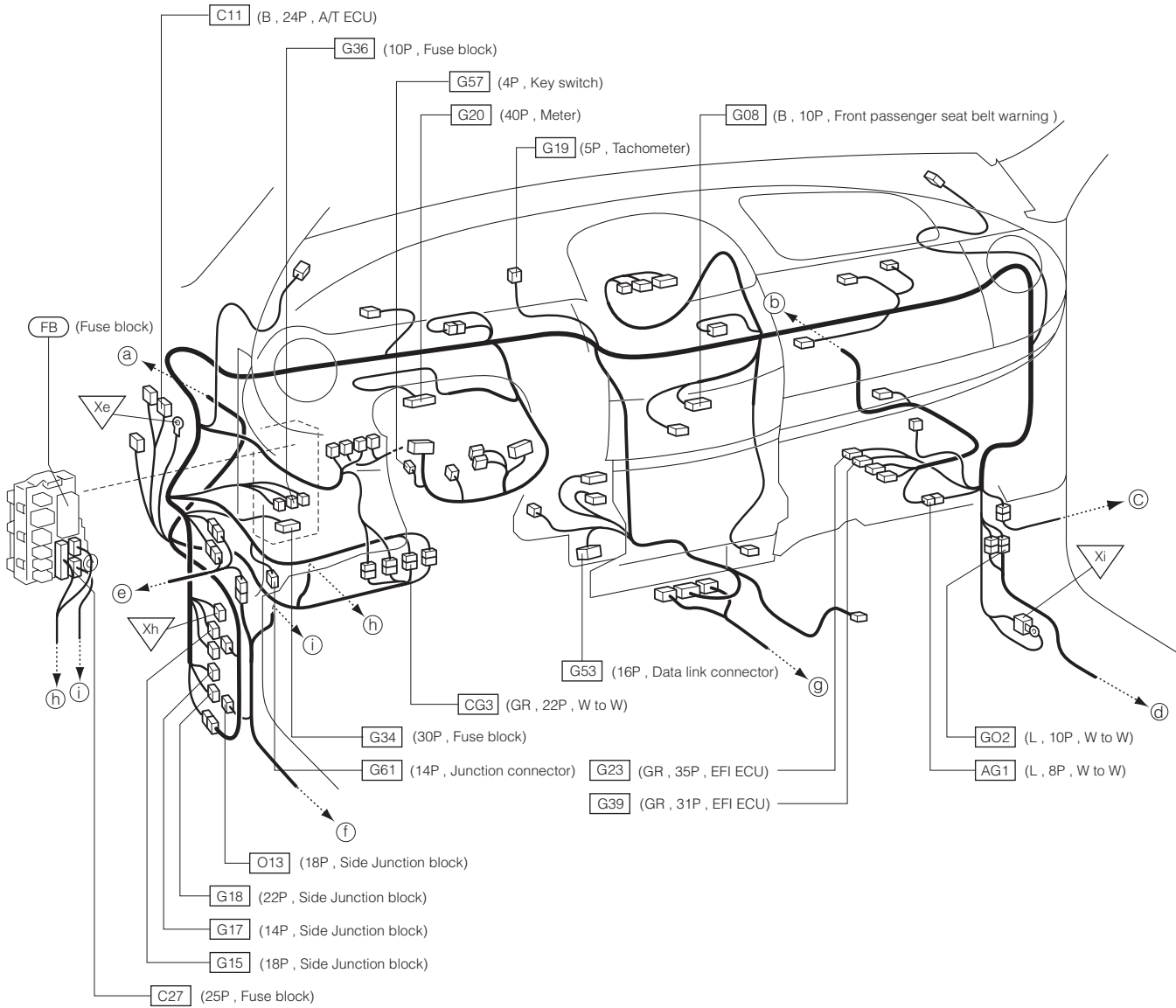

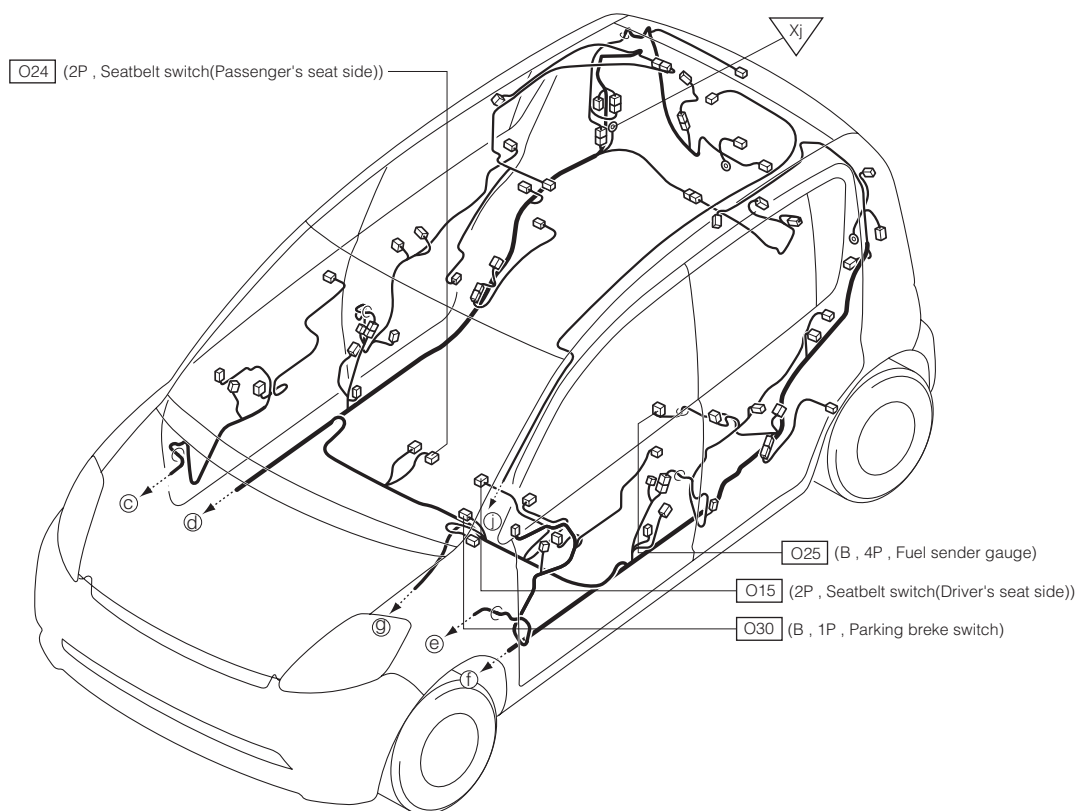
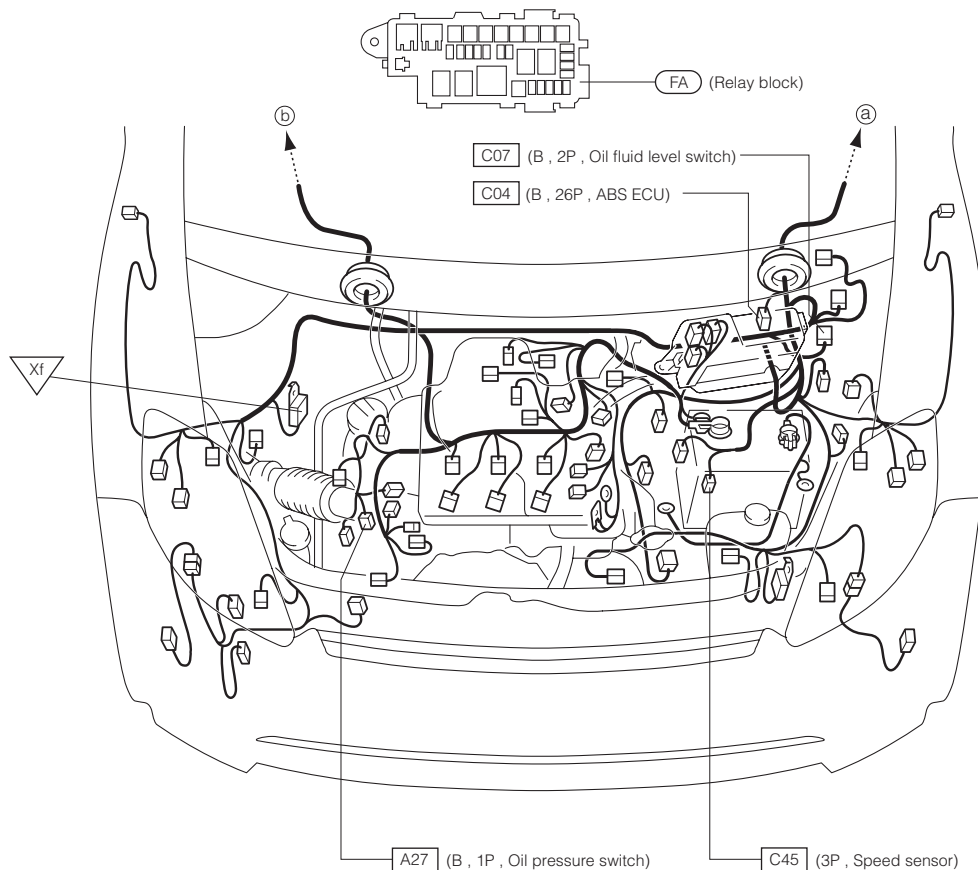

17 HEAD LAMP 17-1 RHD VEHICLE

*1:General export and AUS specification
*2:Except General export and AUS specification

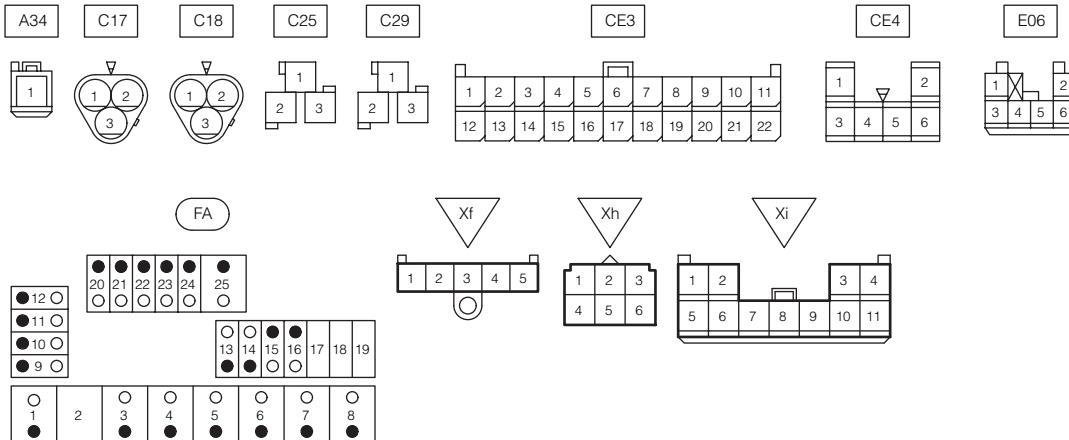
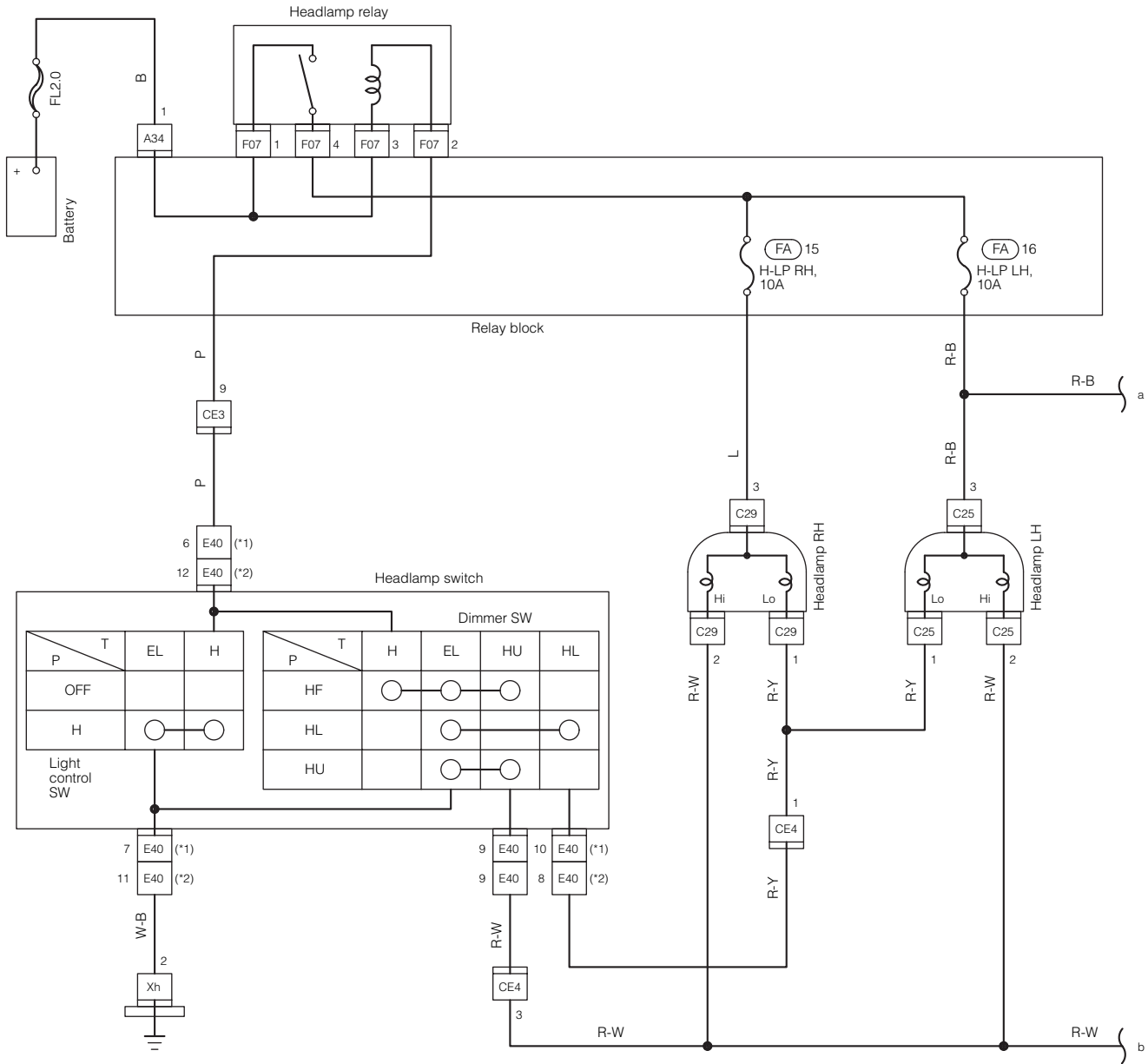

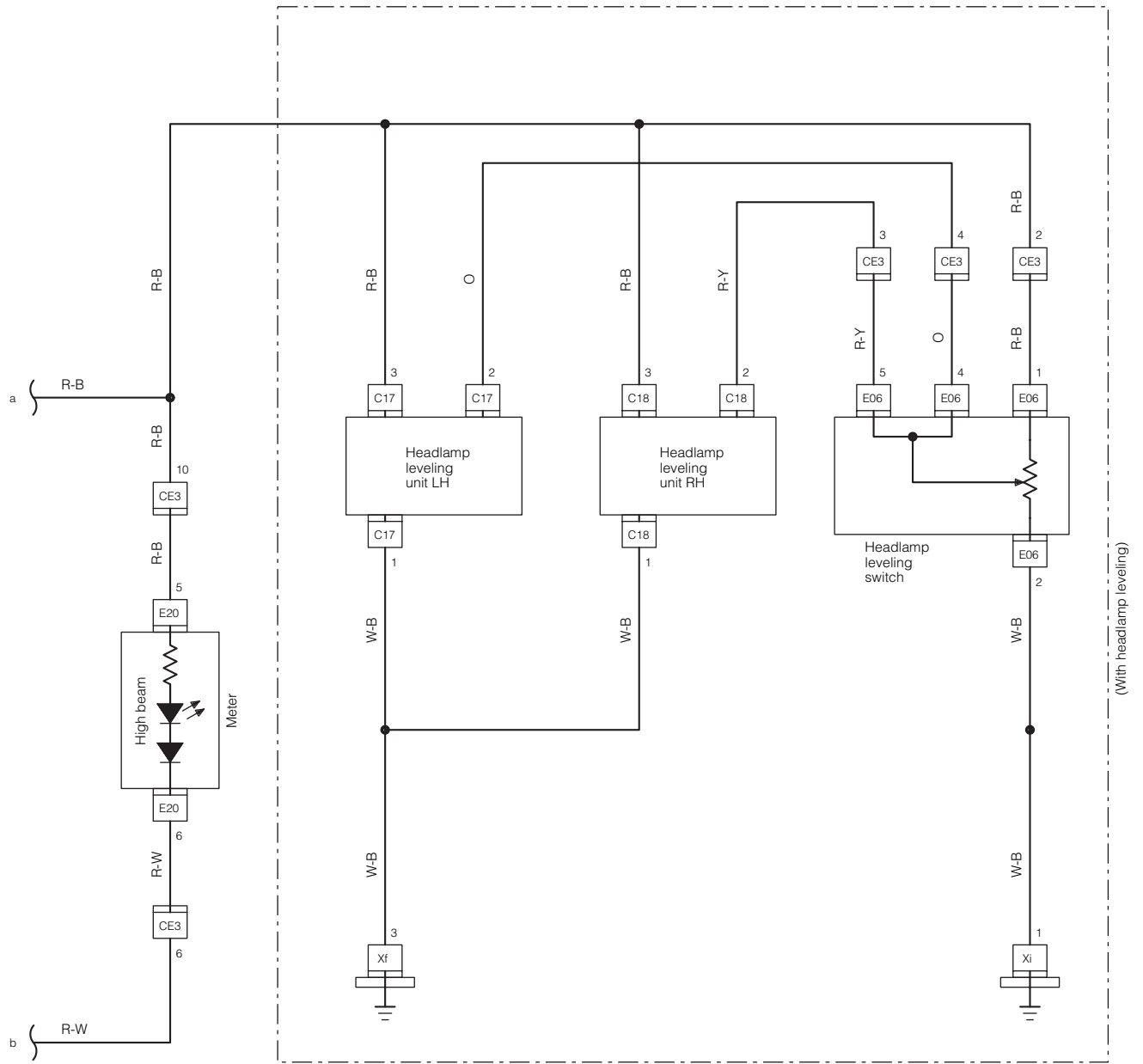

(With headlamp leveling)

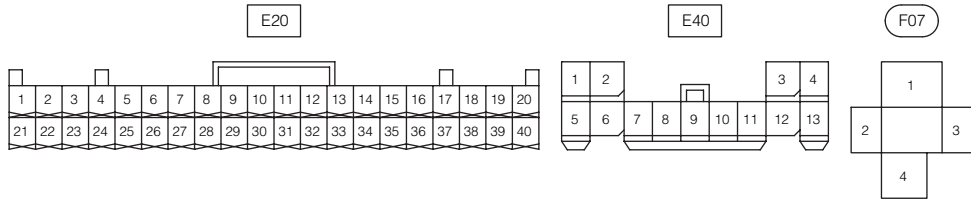

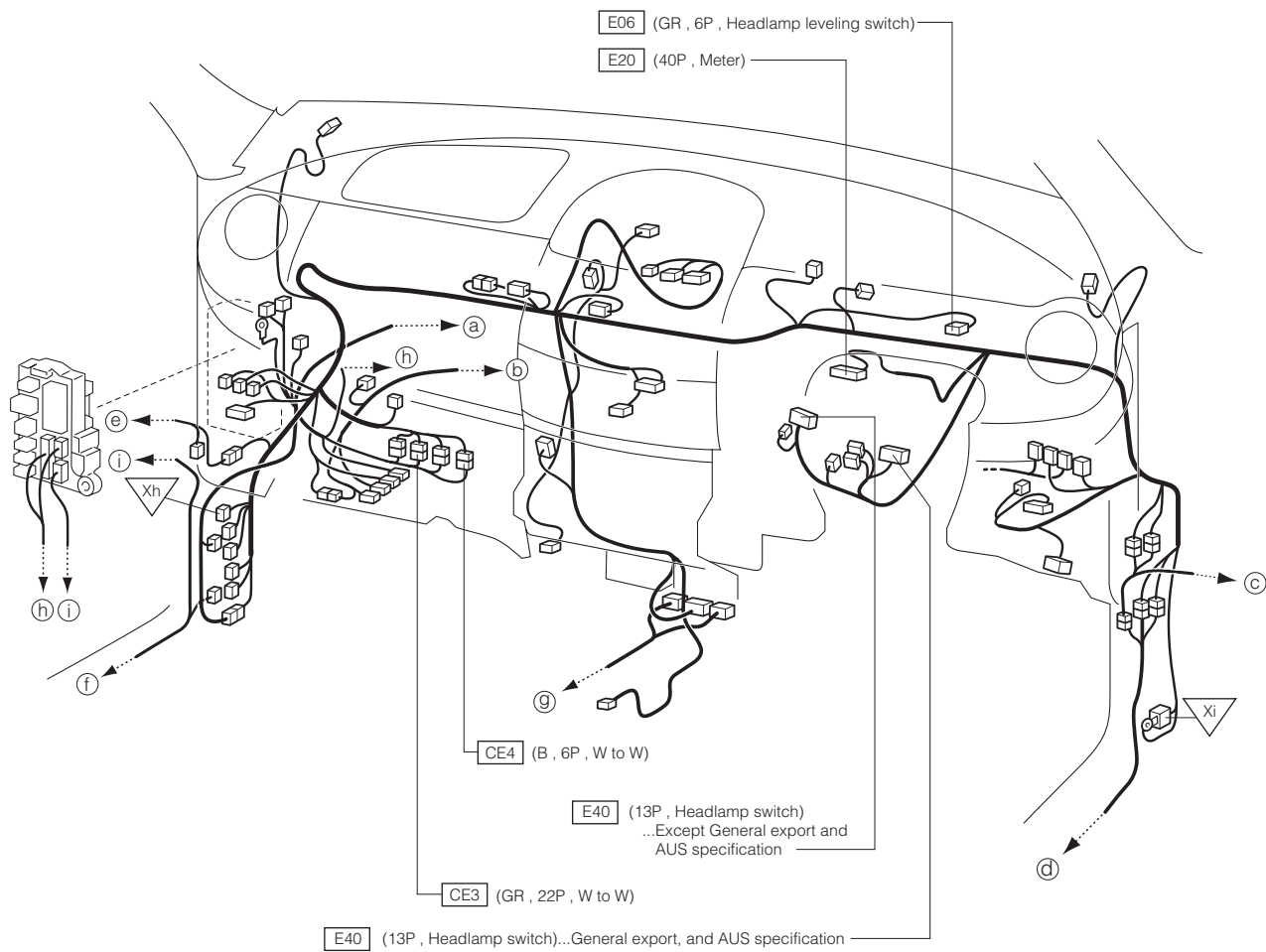

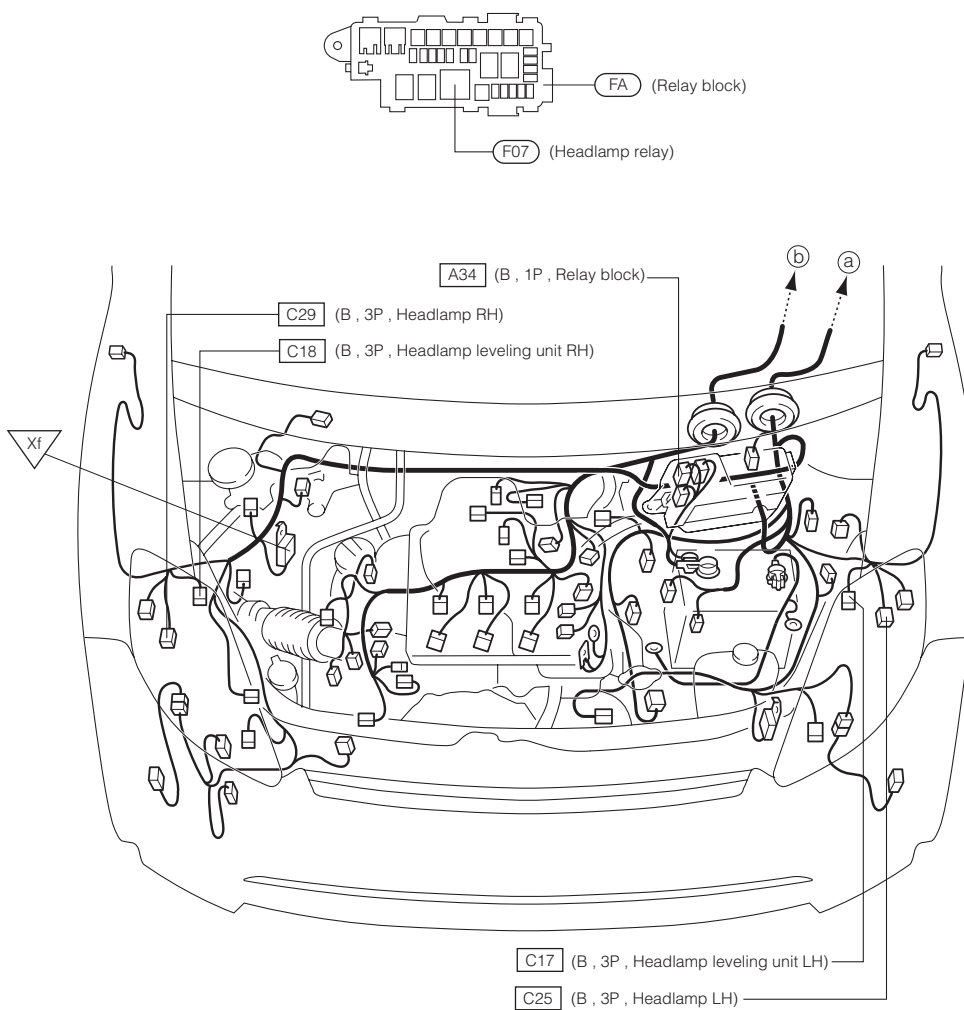

17-2 LHD VEHICLE

*1:1KR-FE
*2:K3-VE

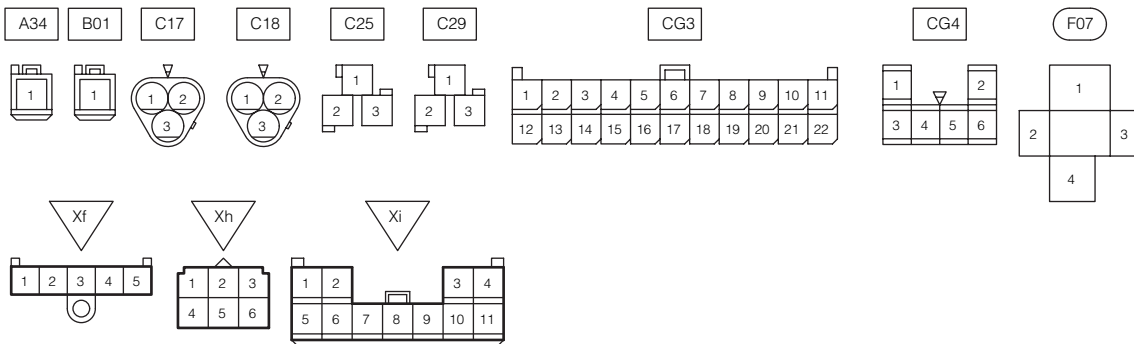
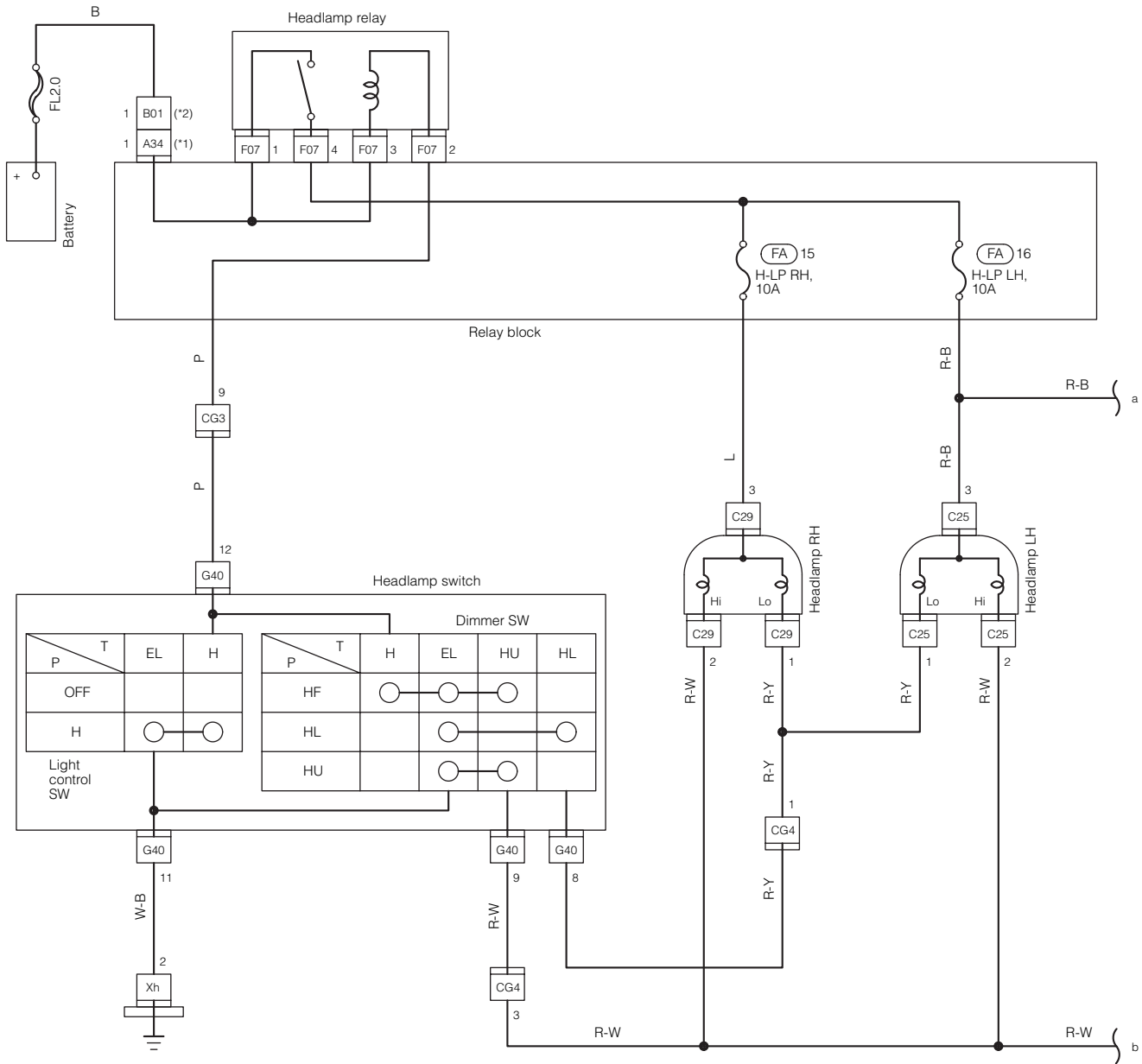

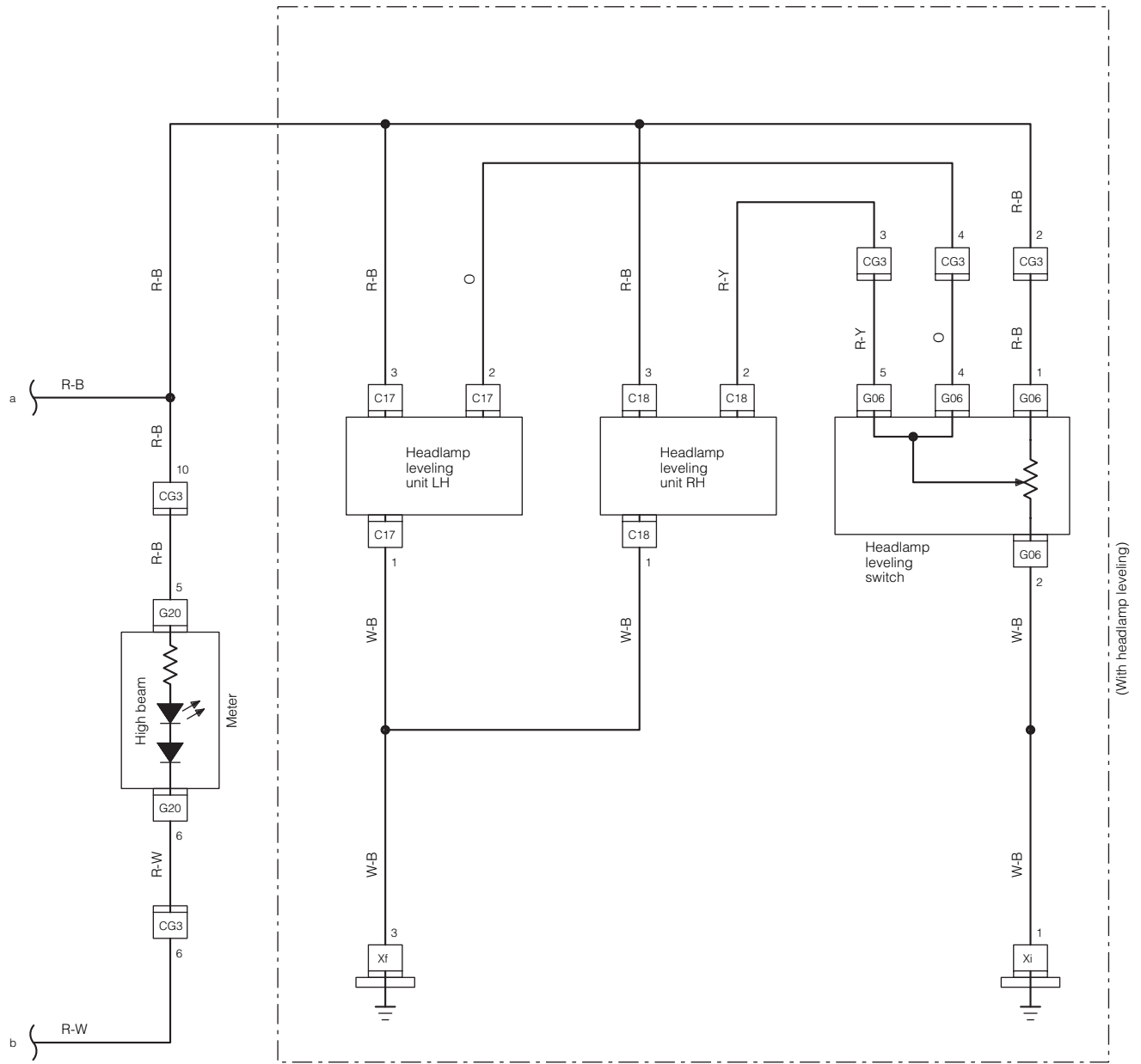

(With headlamp leveling)

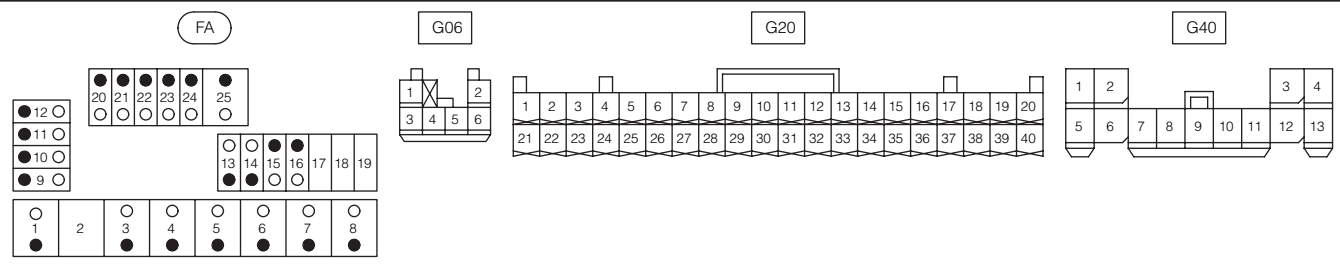

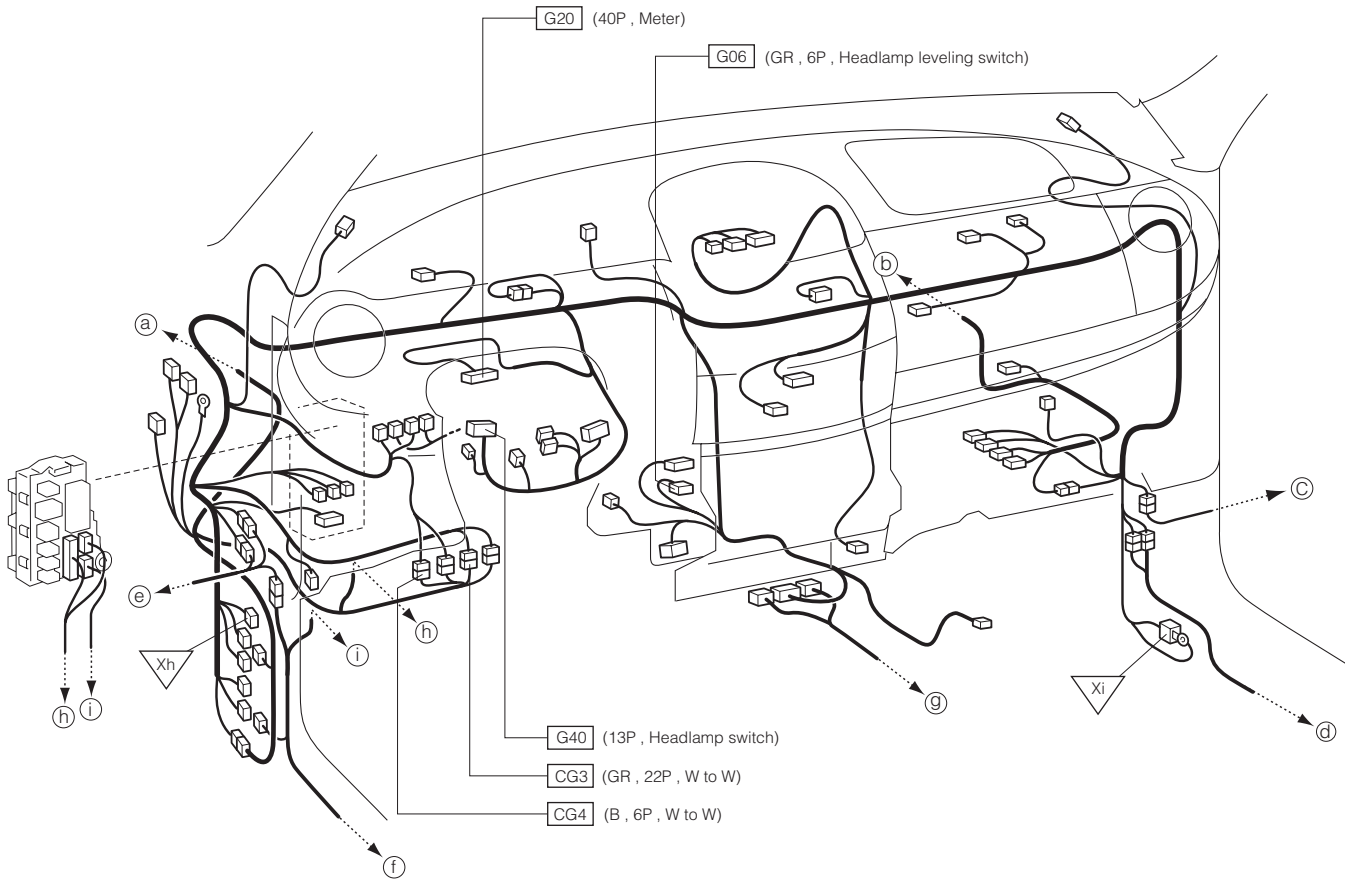

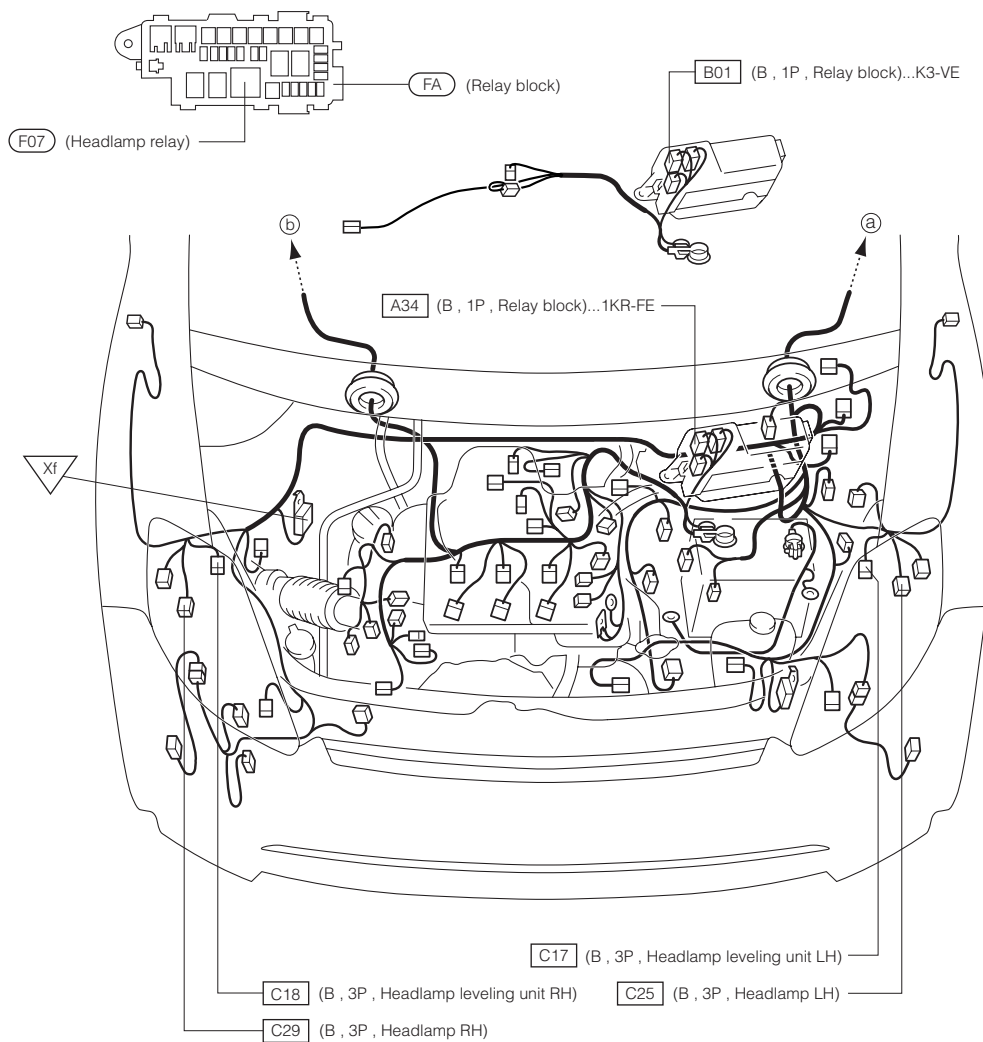

D-157

18 FOG LAMP 18-1 RHD VEHICLE

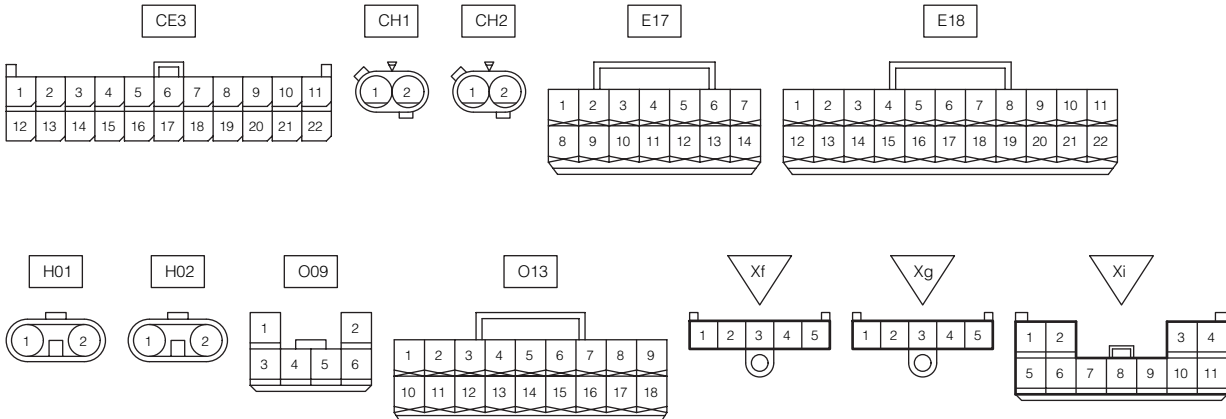
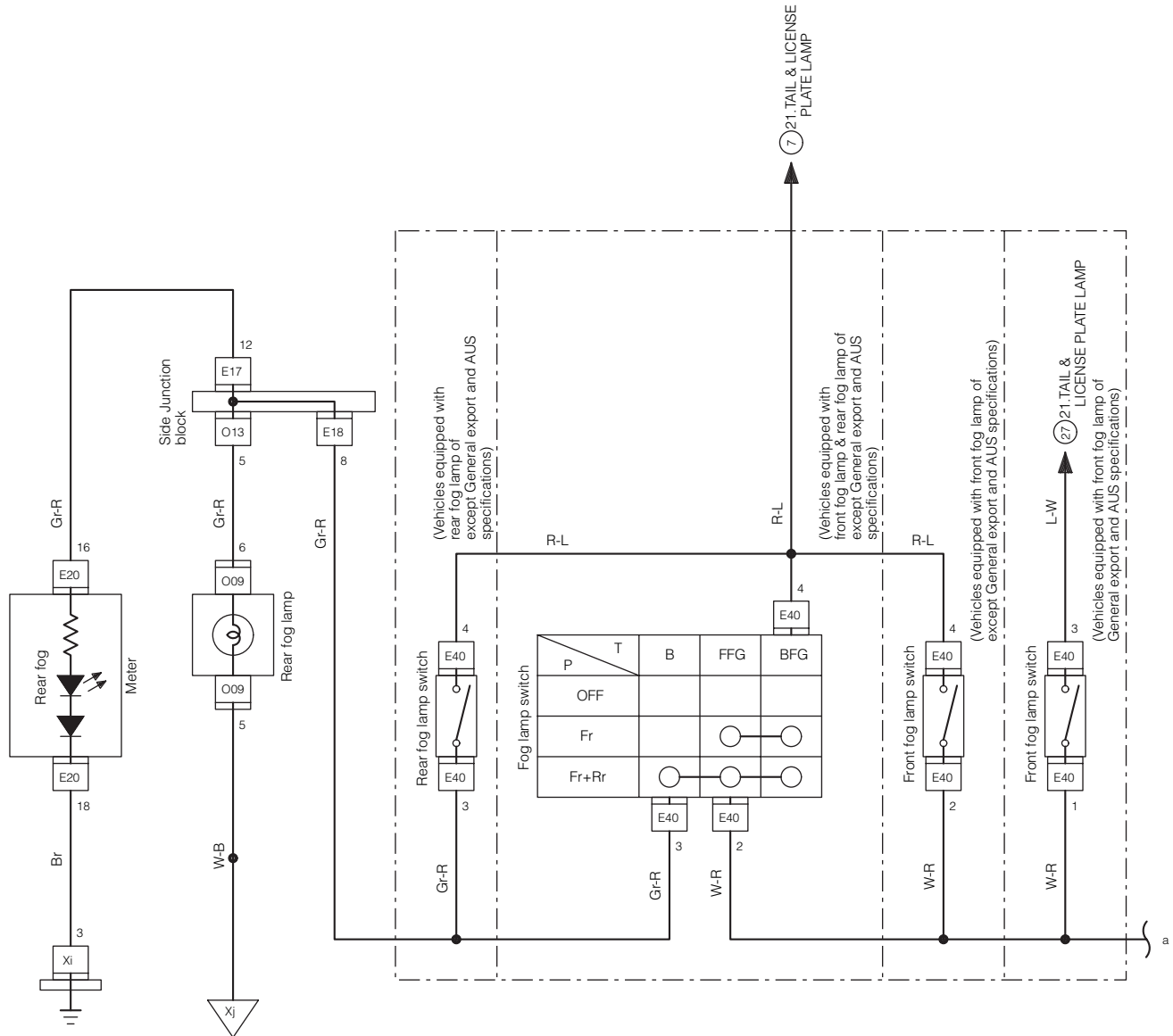

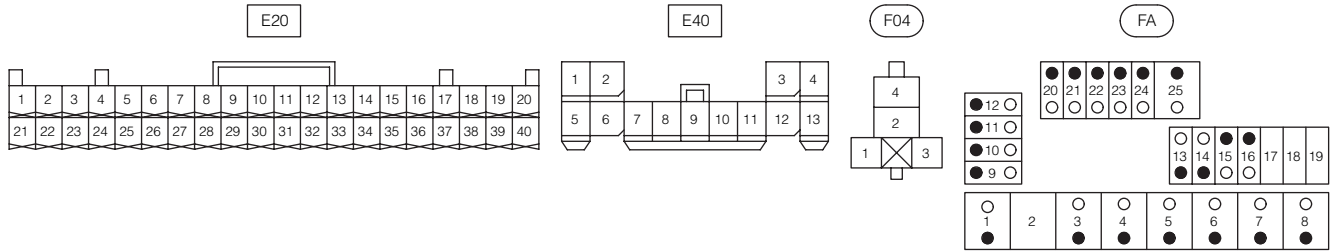
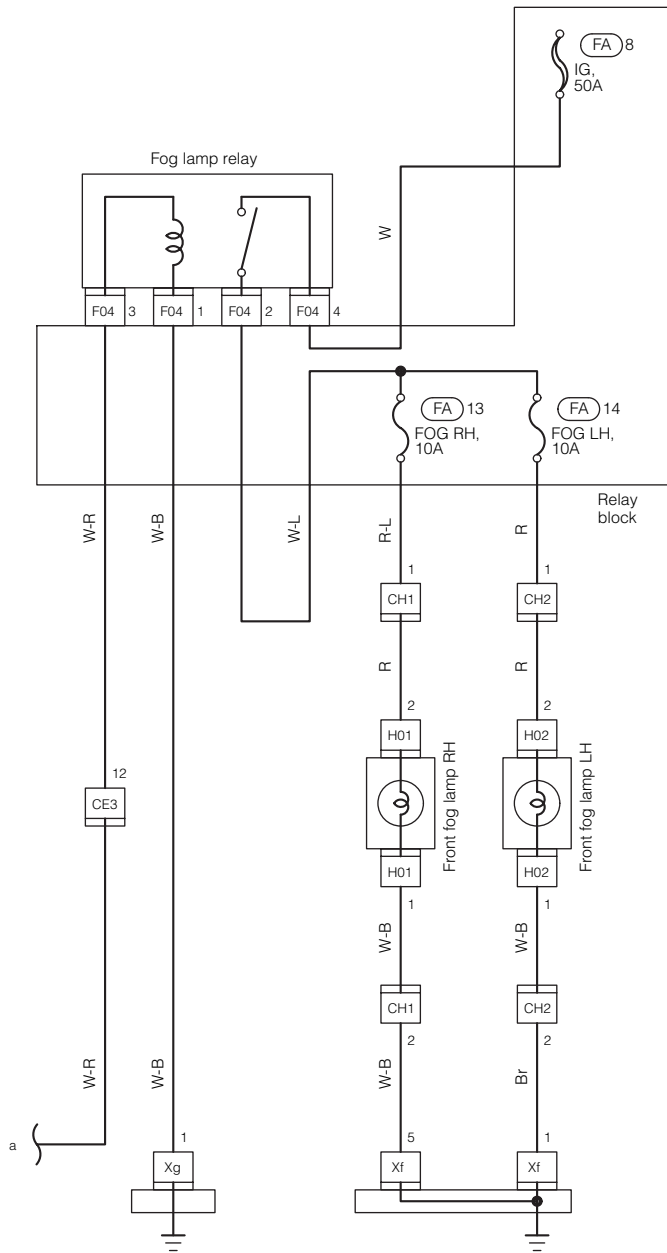

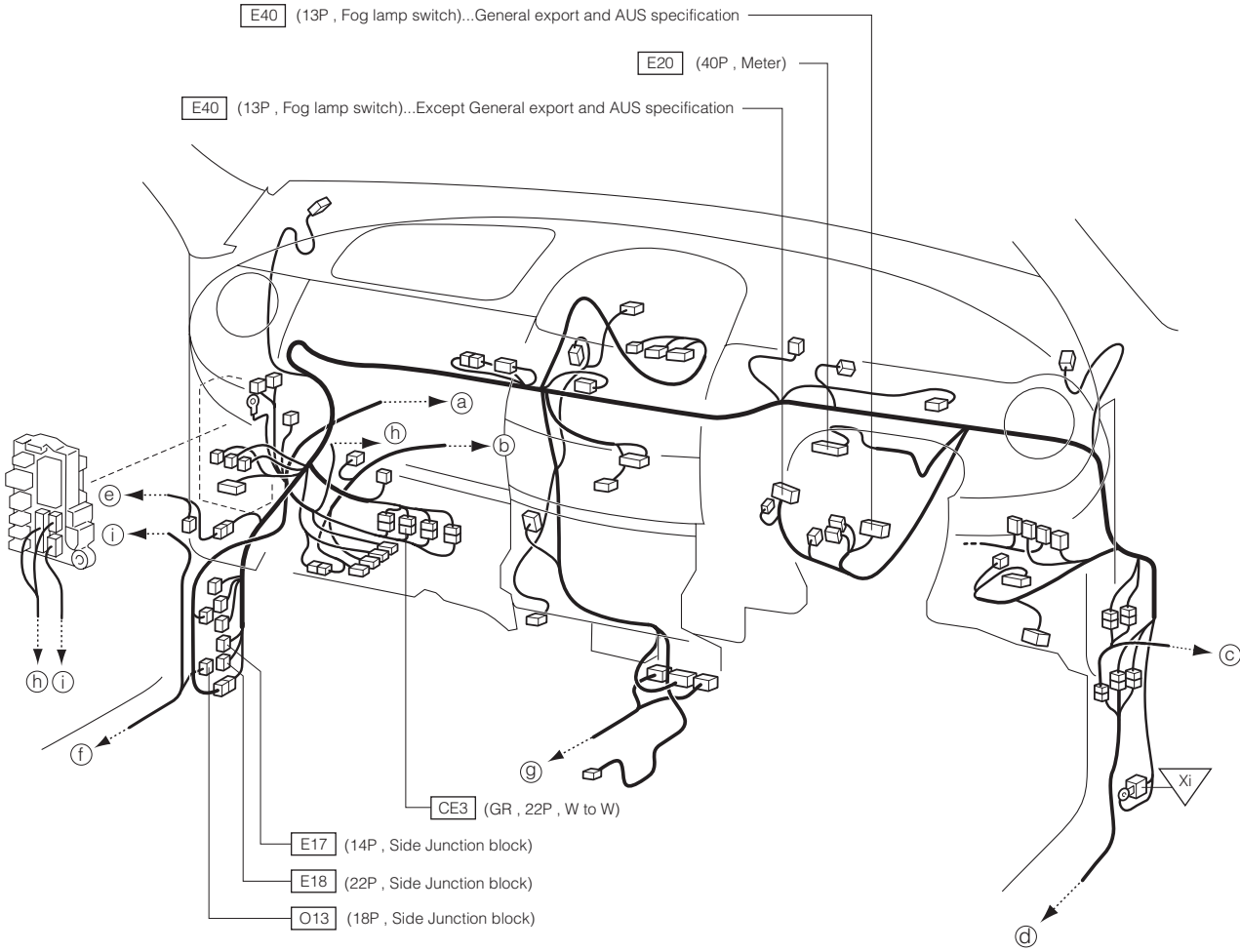

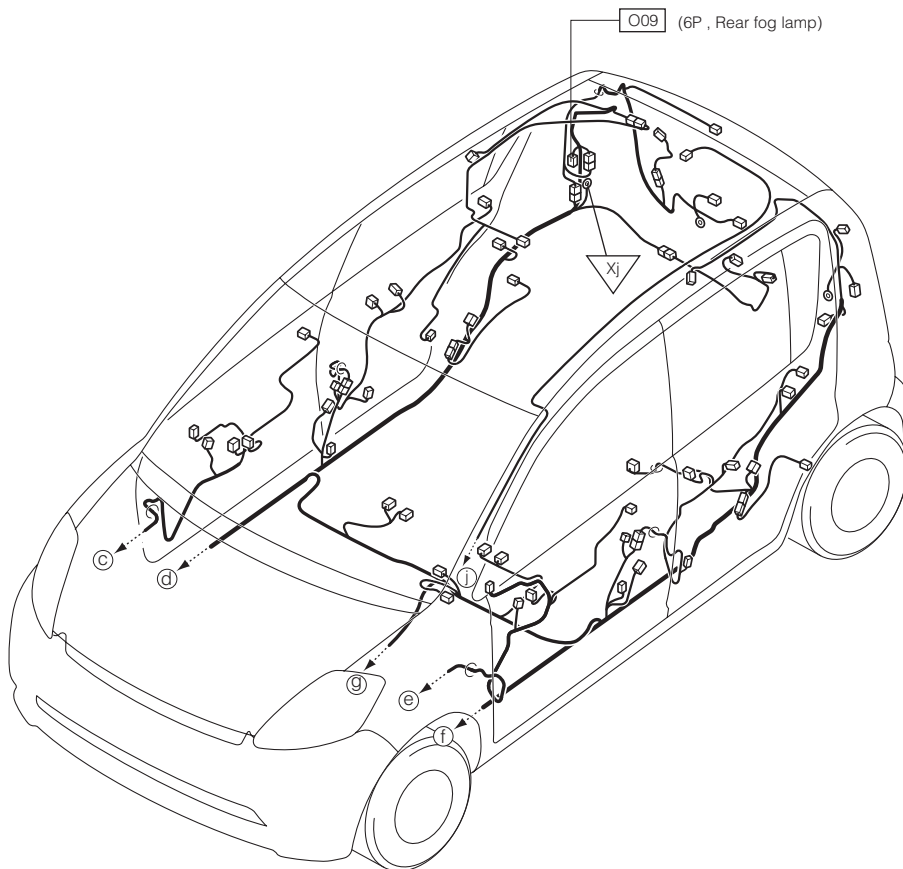
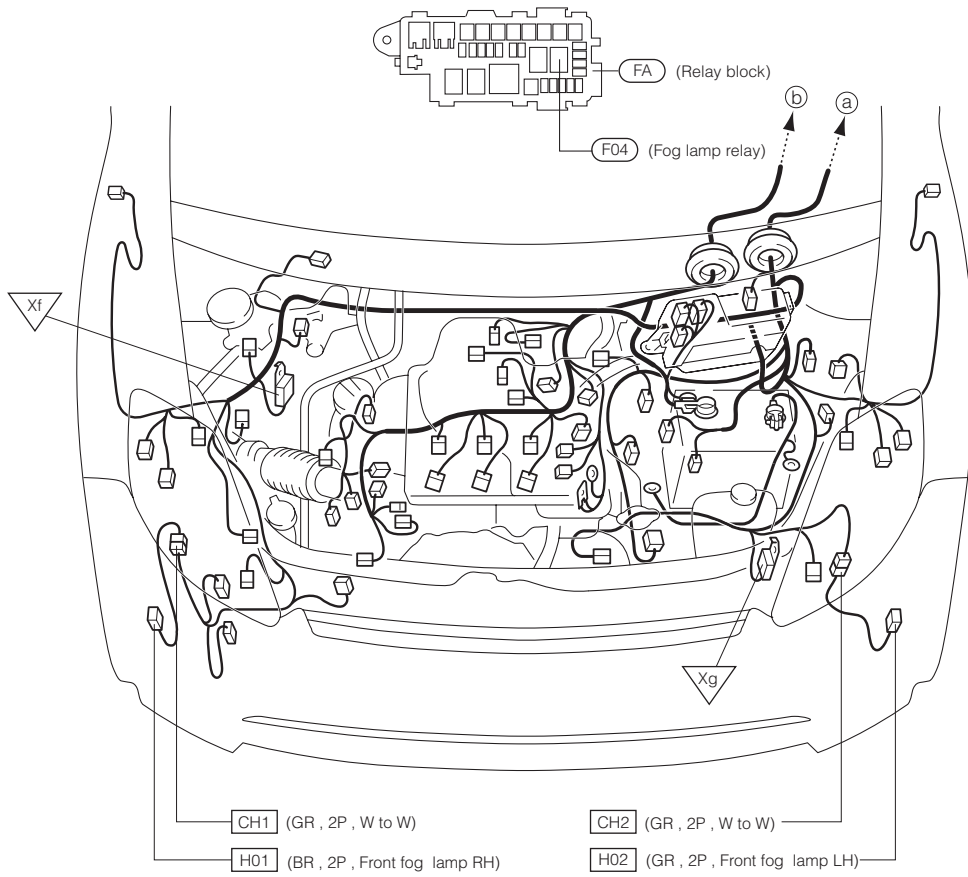

18-2 LHD VEHICLE

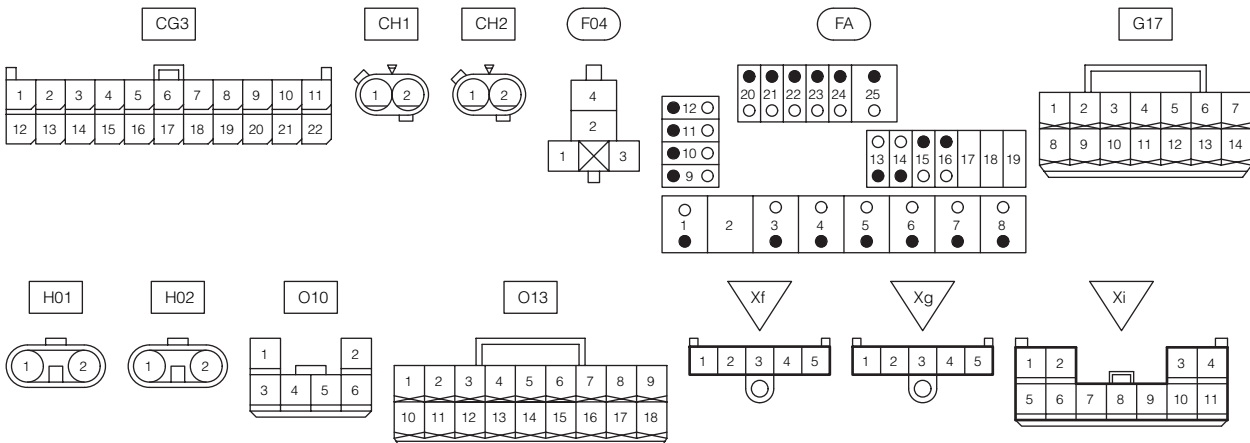
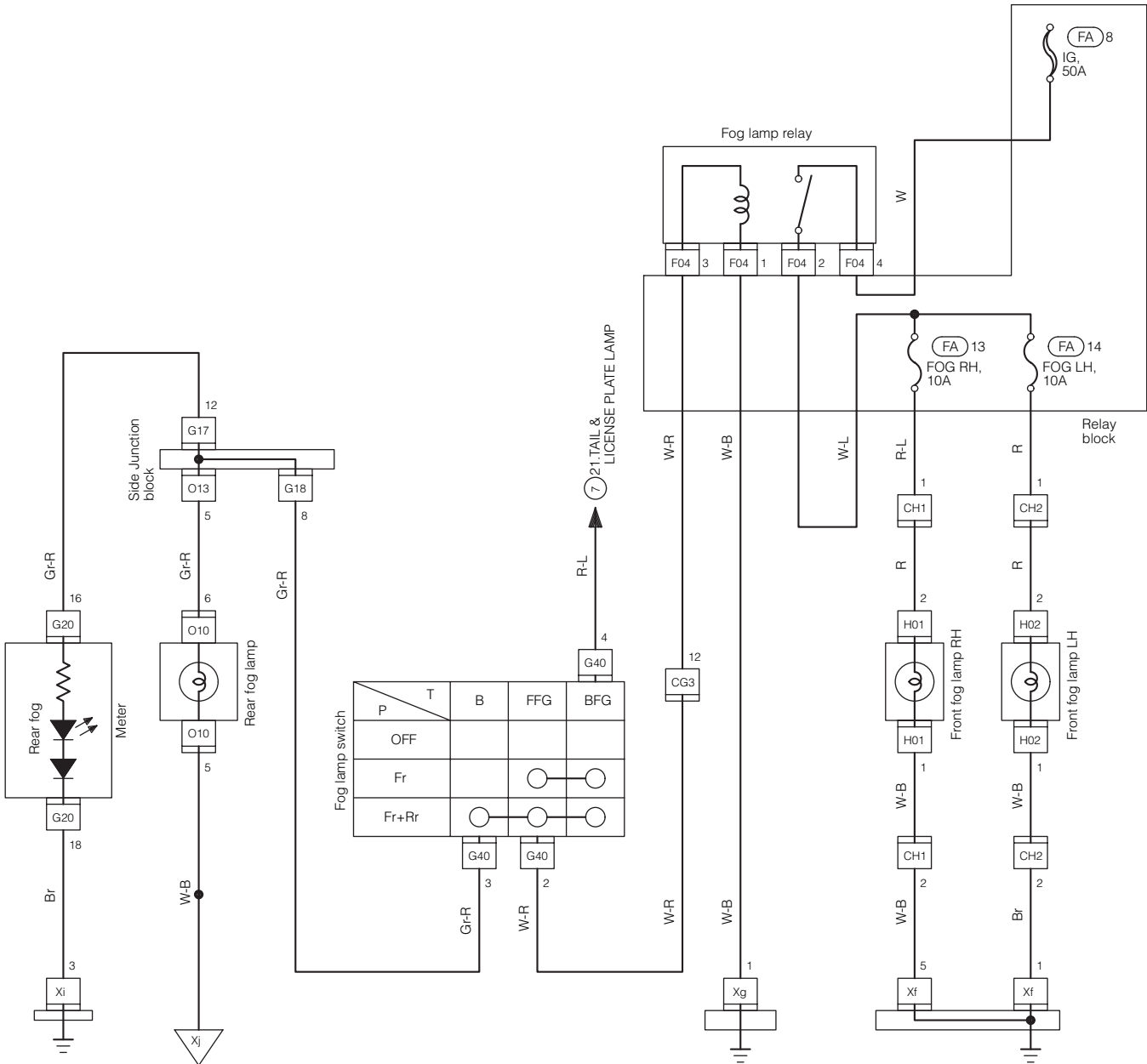

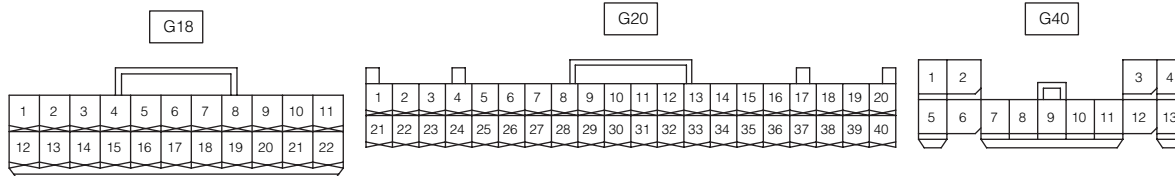

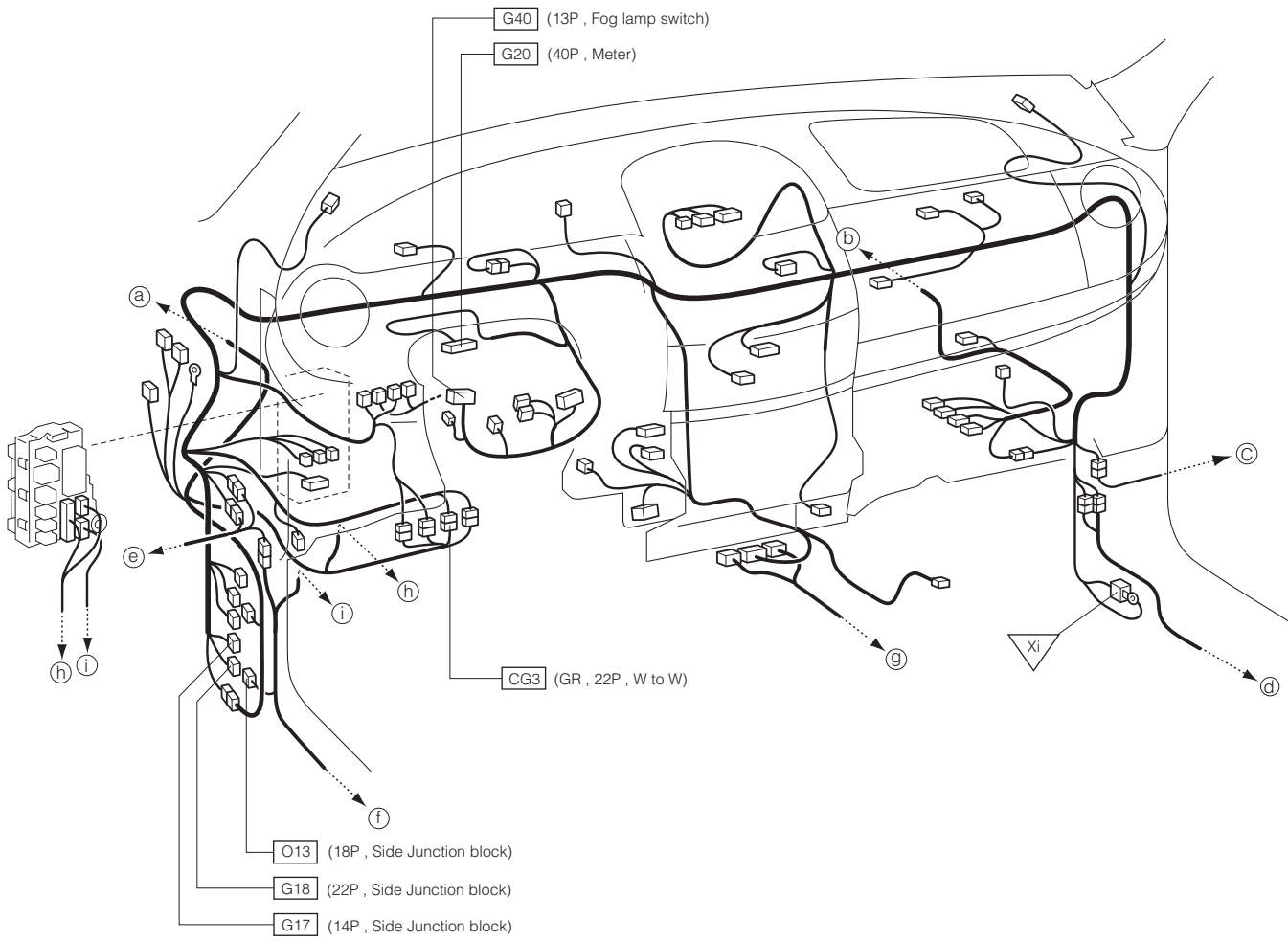

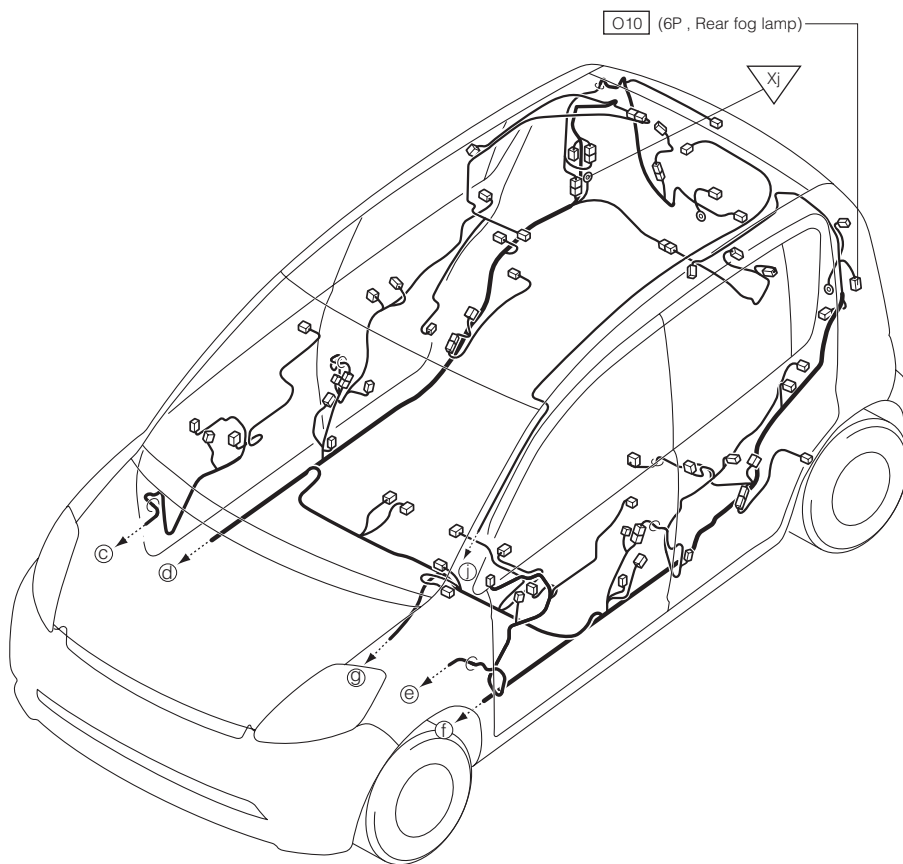
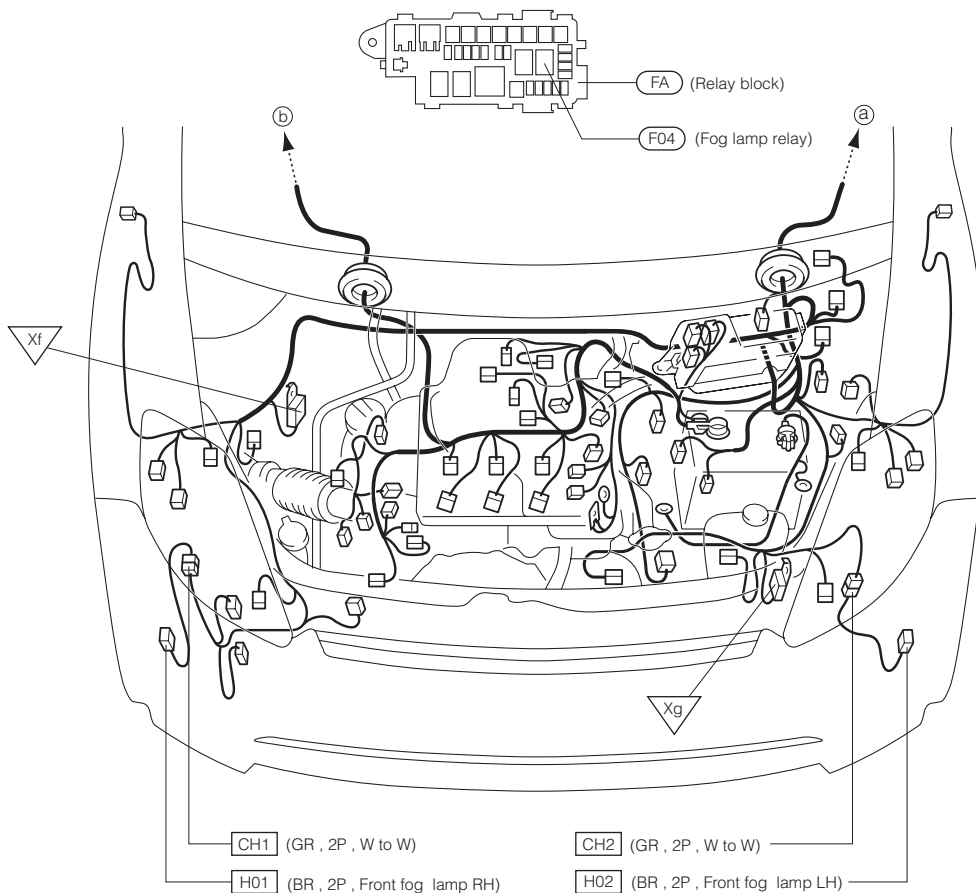

19 HAZARD WARNING & TURN SIGNAL LAMP 19-1 RHD VEHICLE

*1: General export and AUS specification
*2: Except General export and AUS specification

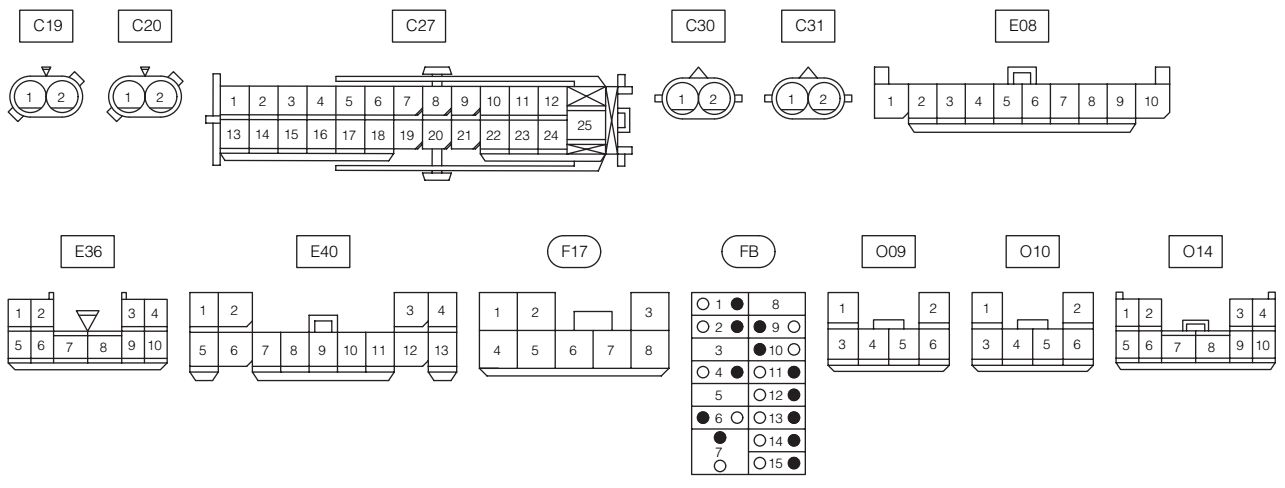
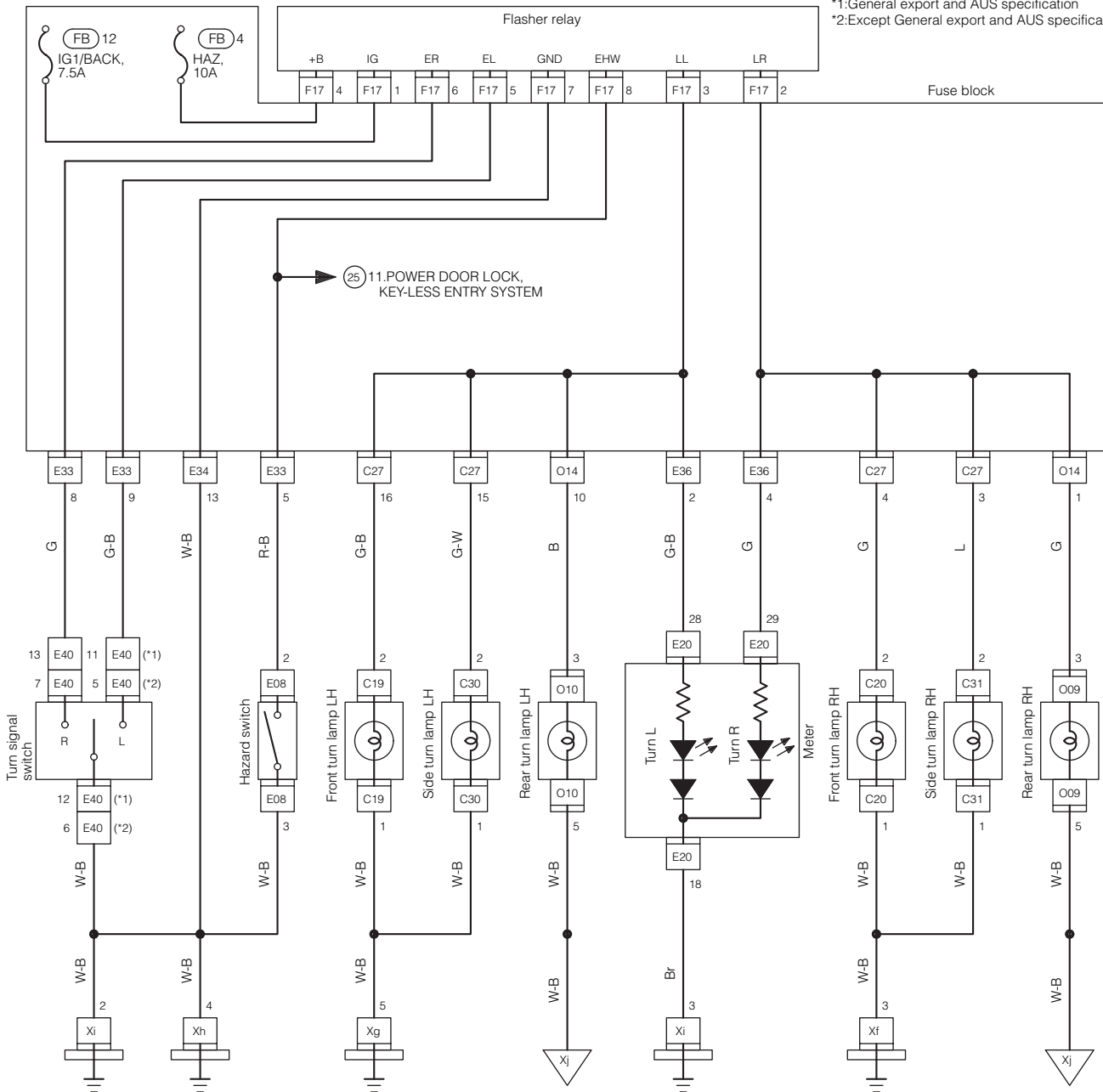

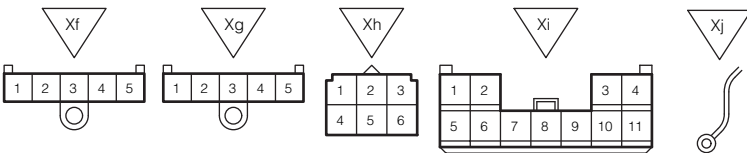
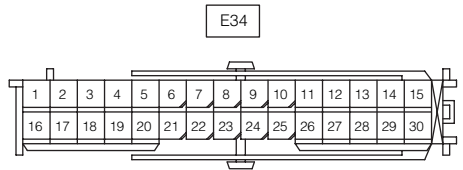
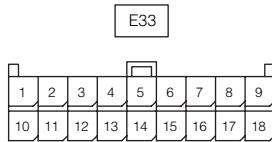

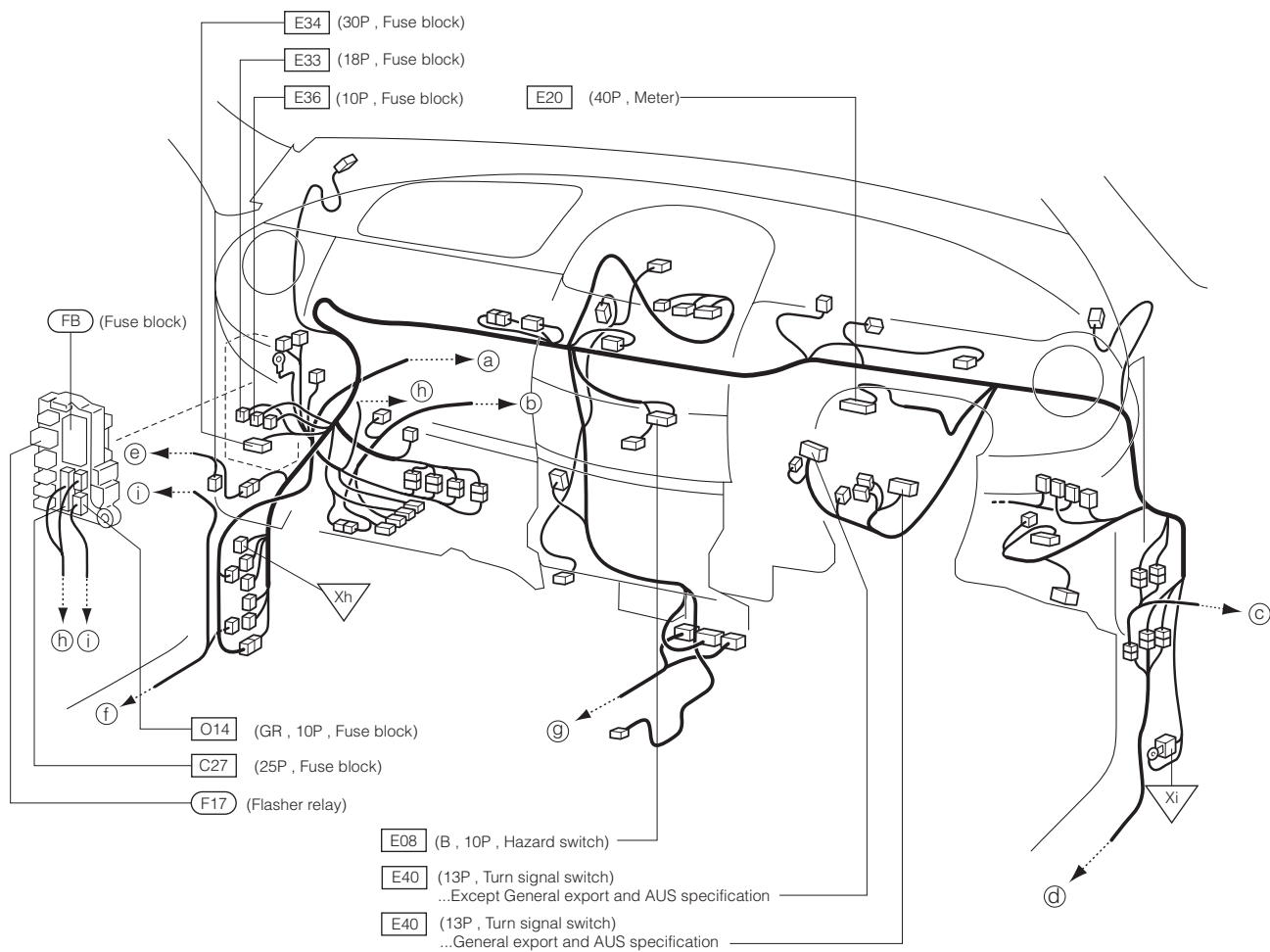

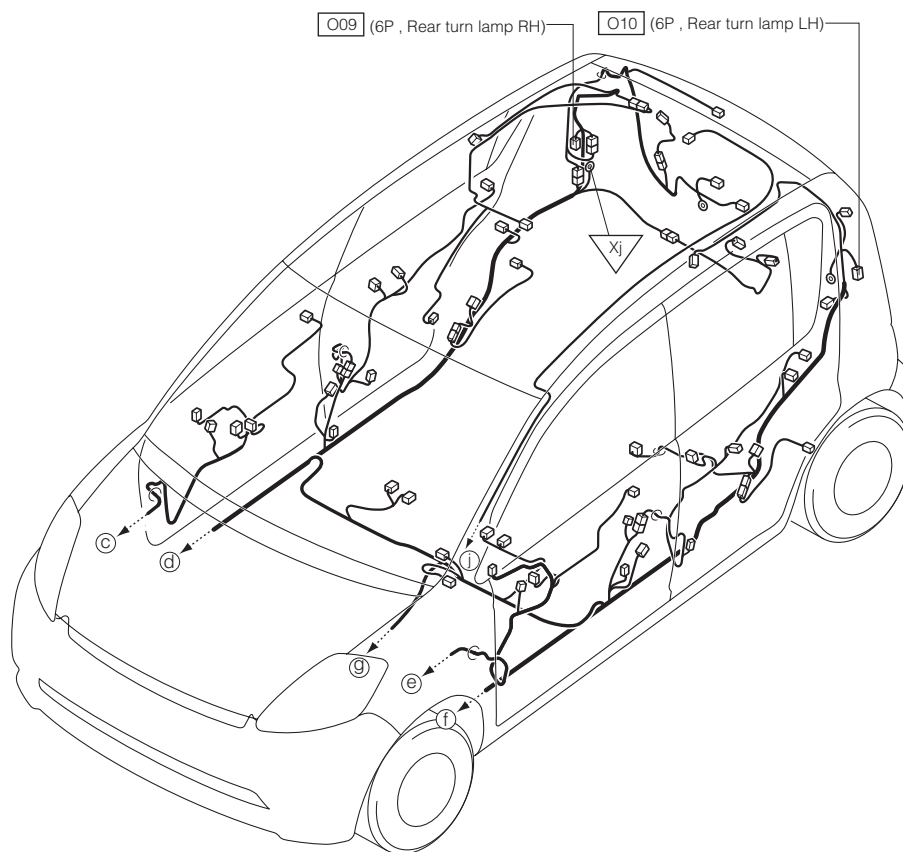
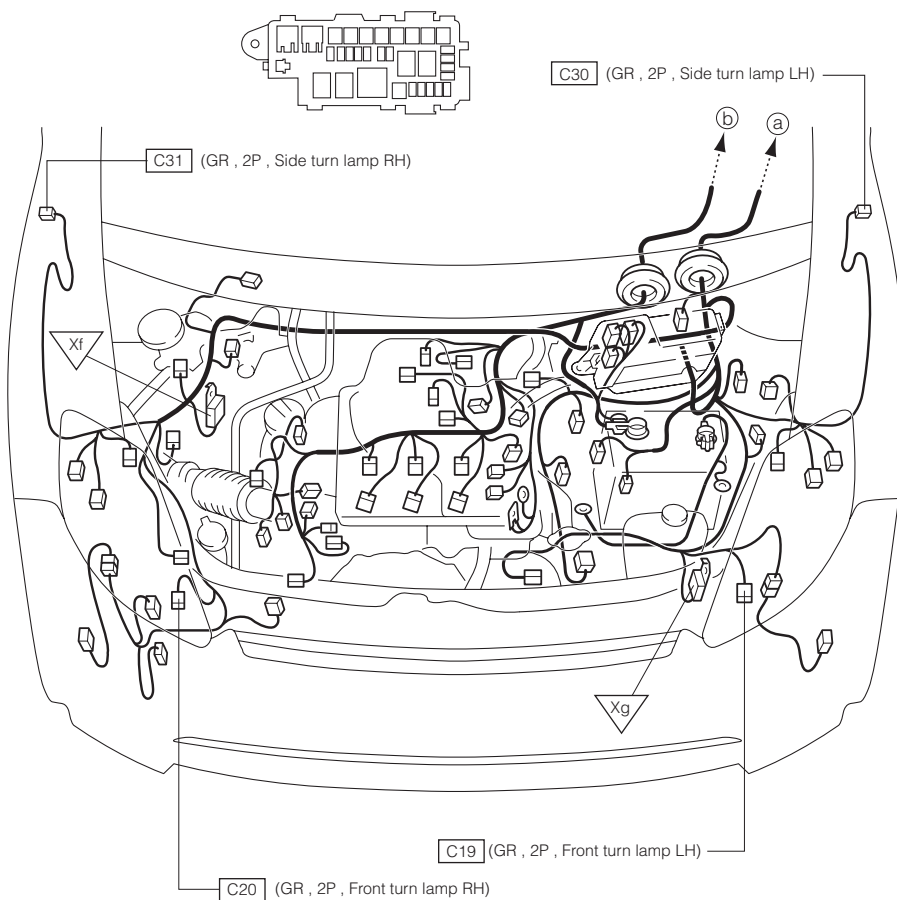

19-2 LHD VEHICLE

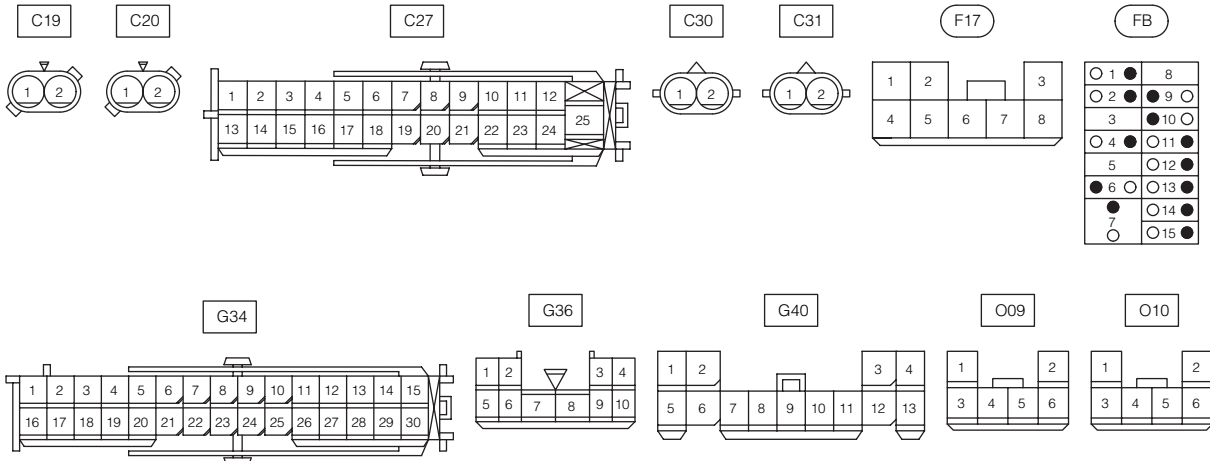
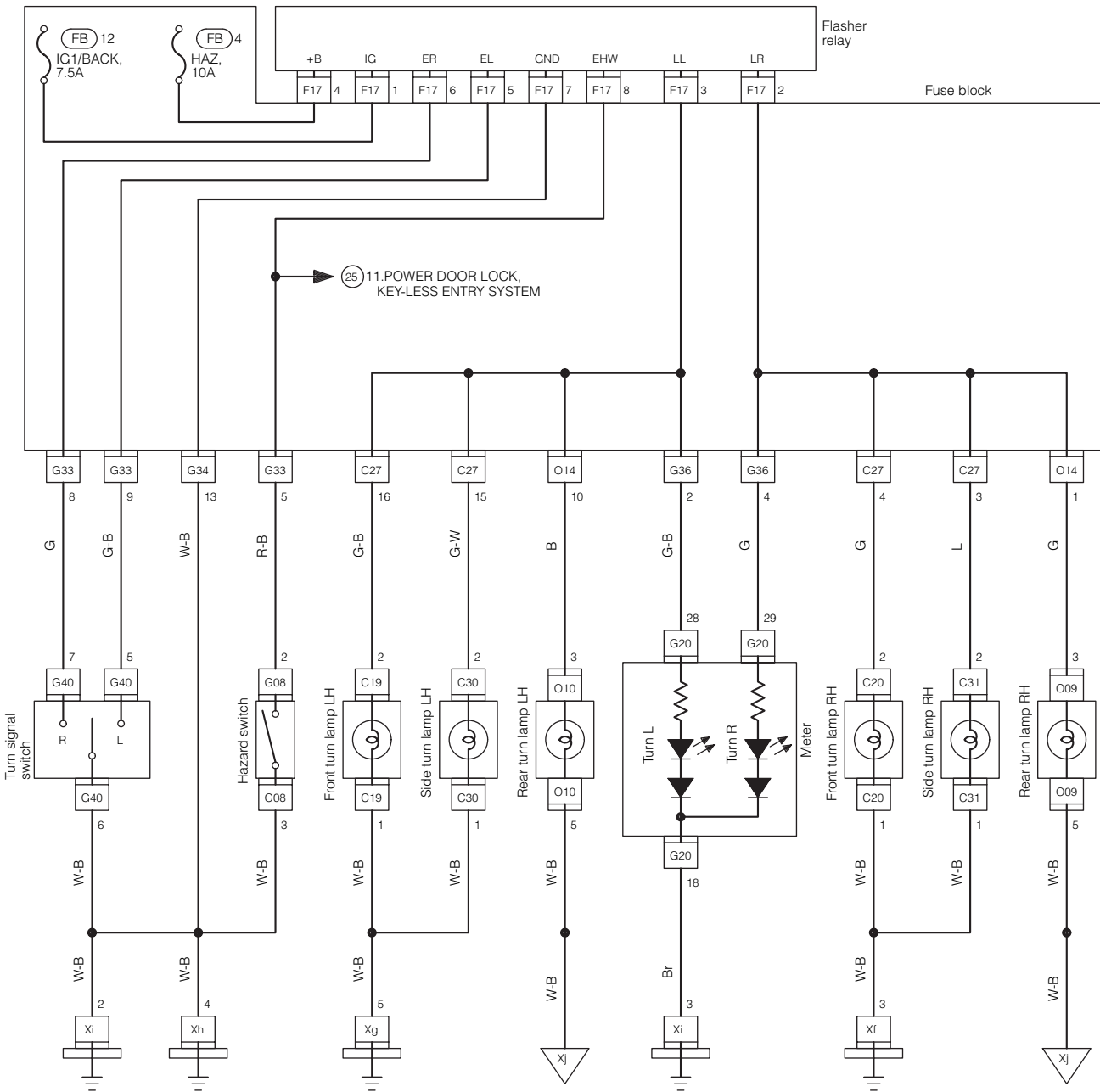

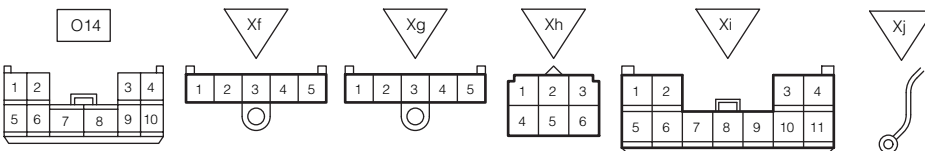

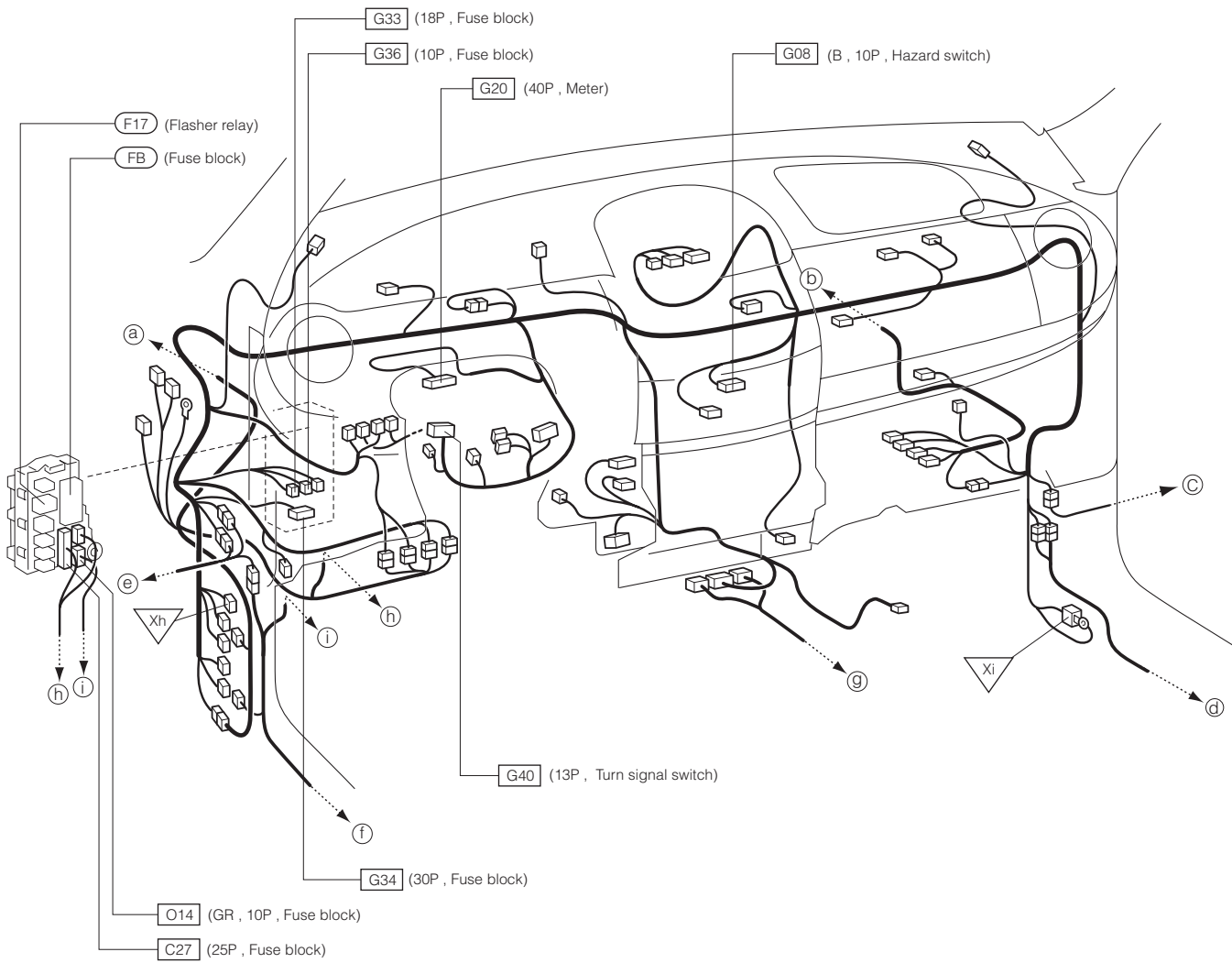

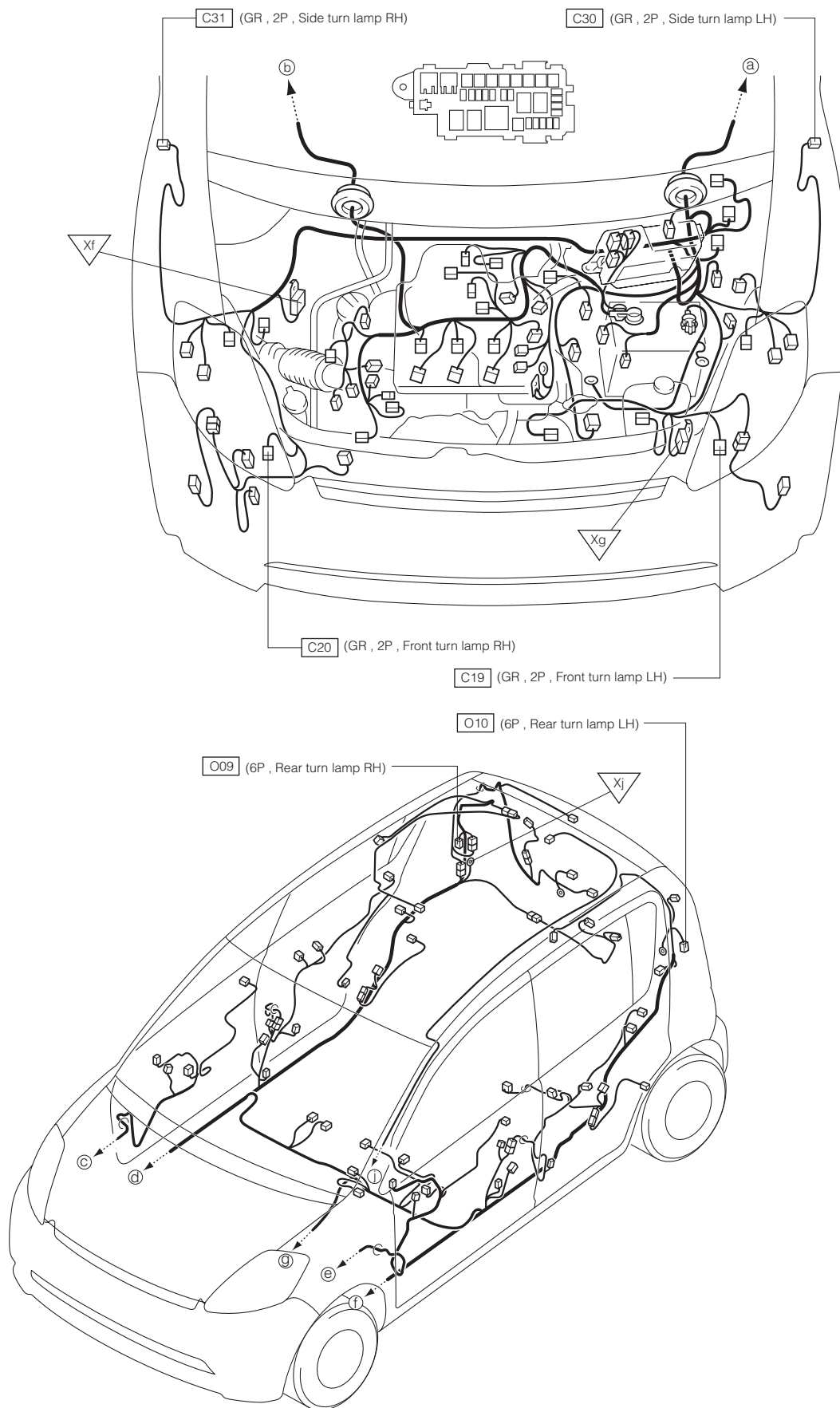

D-173

20 STOP LAMP 20-1 RHD VEHICLE

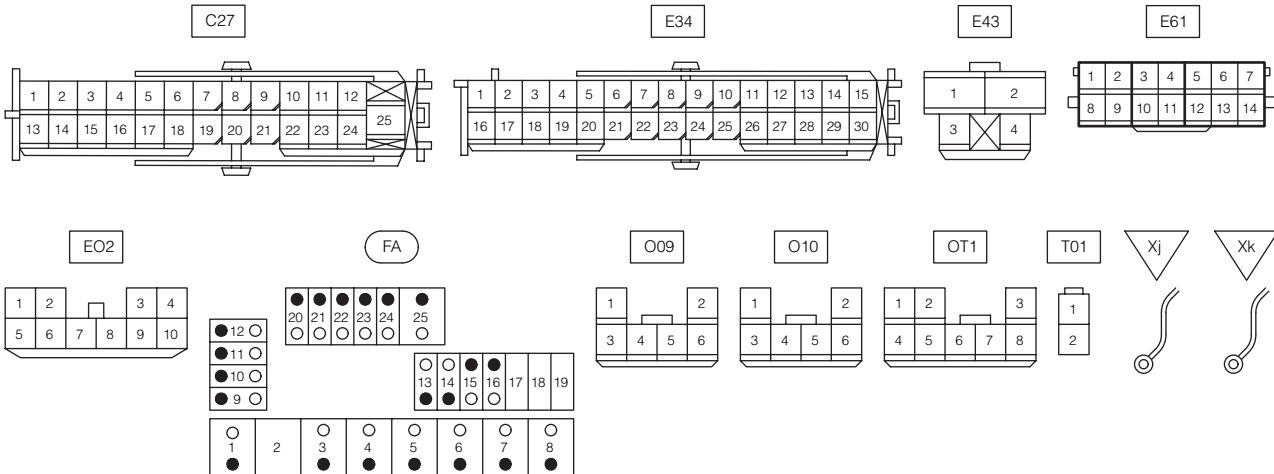
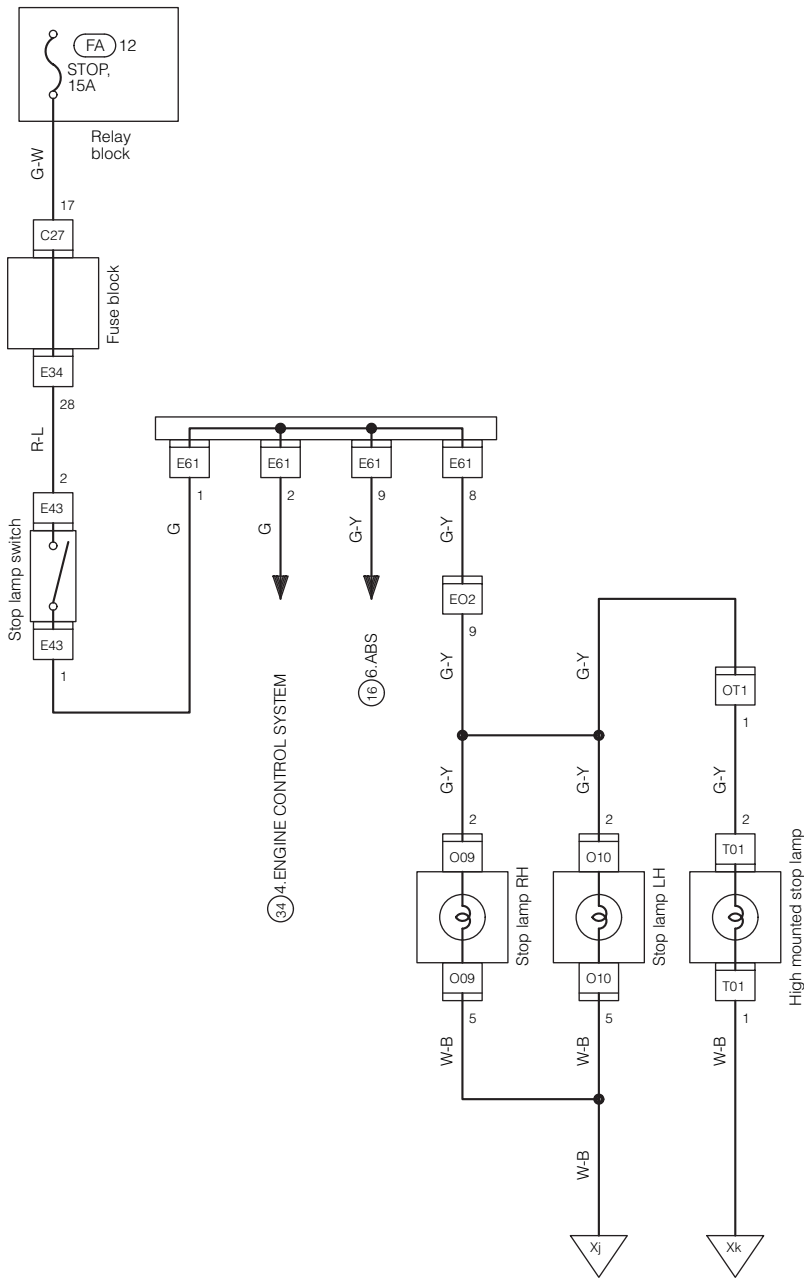

(MEMO)

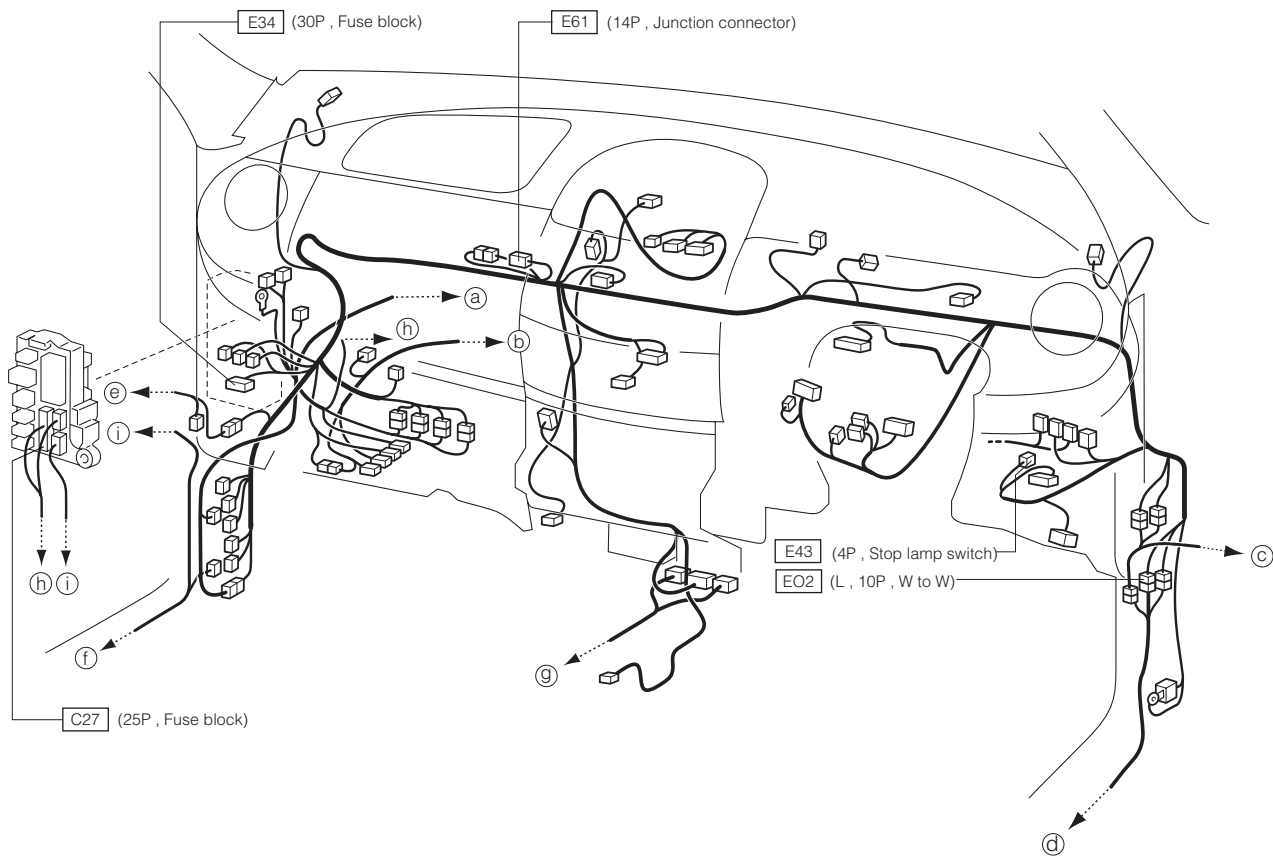

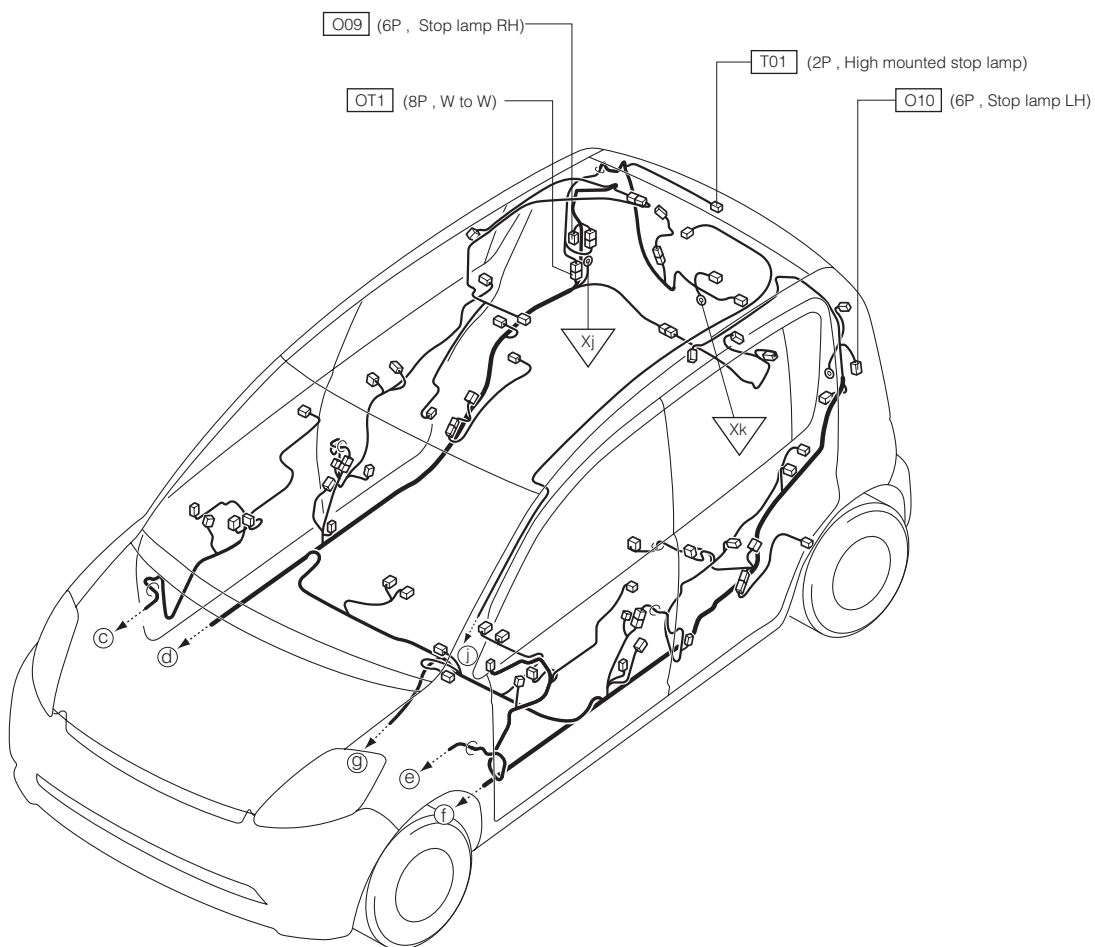
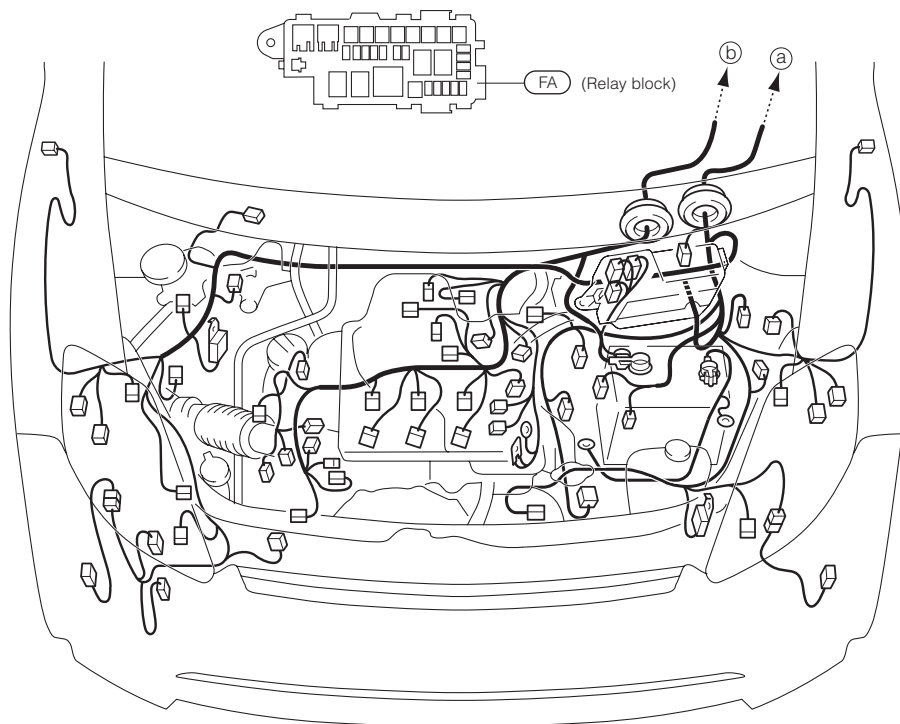

20-2 LHD VEHICLE

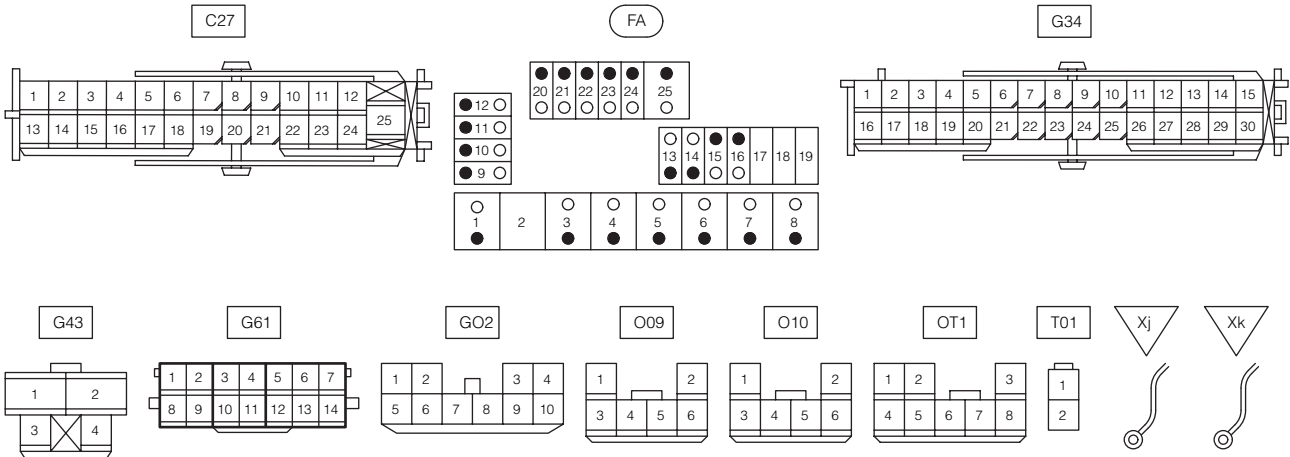
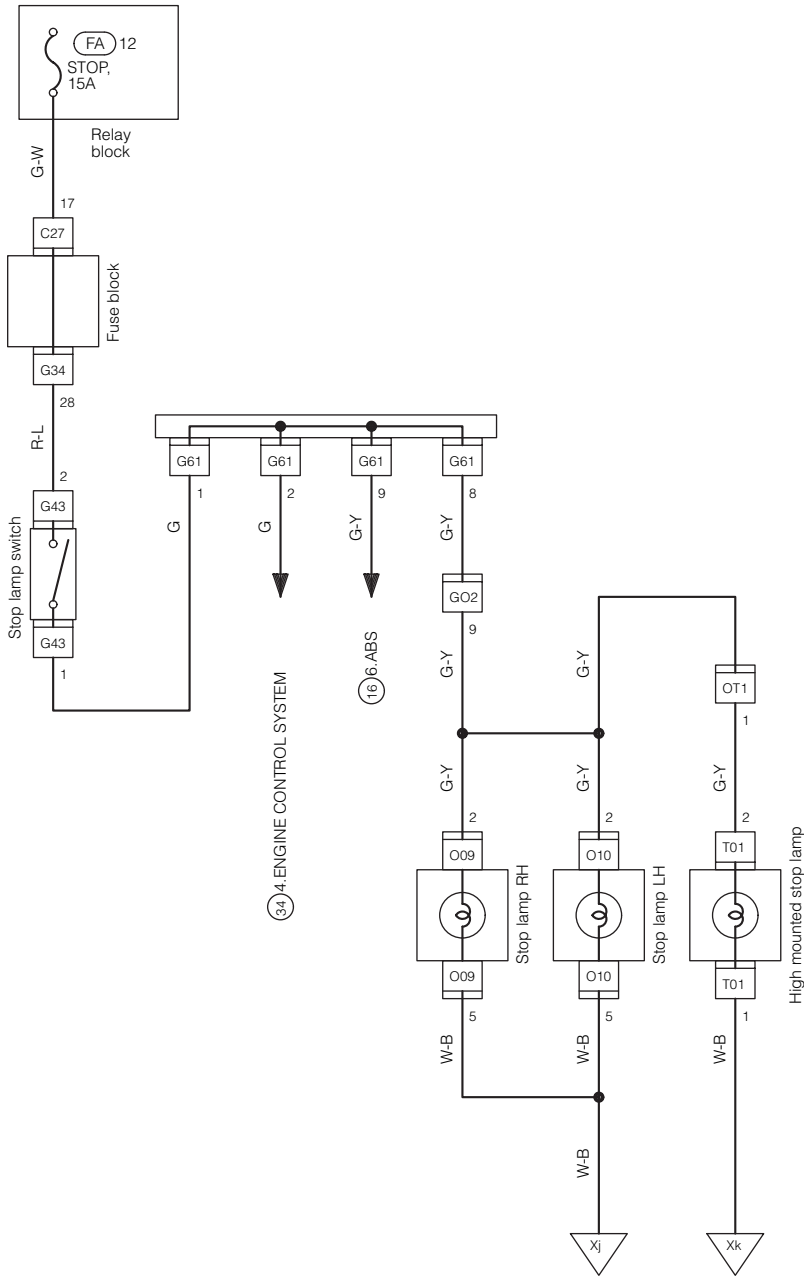

(MEMO)

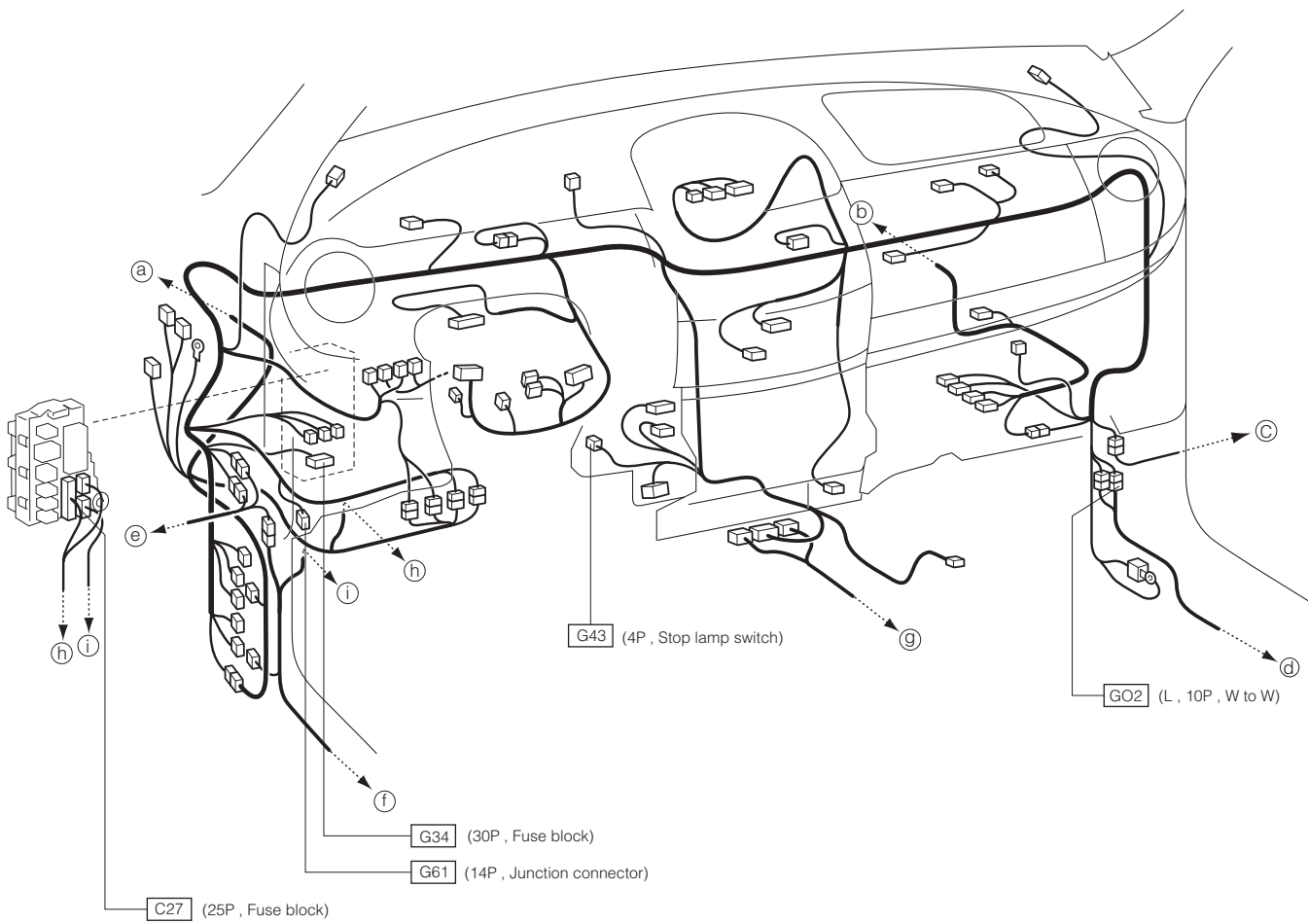

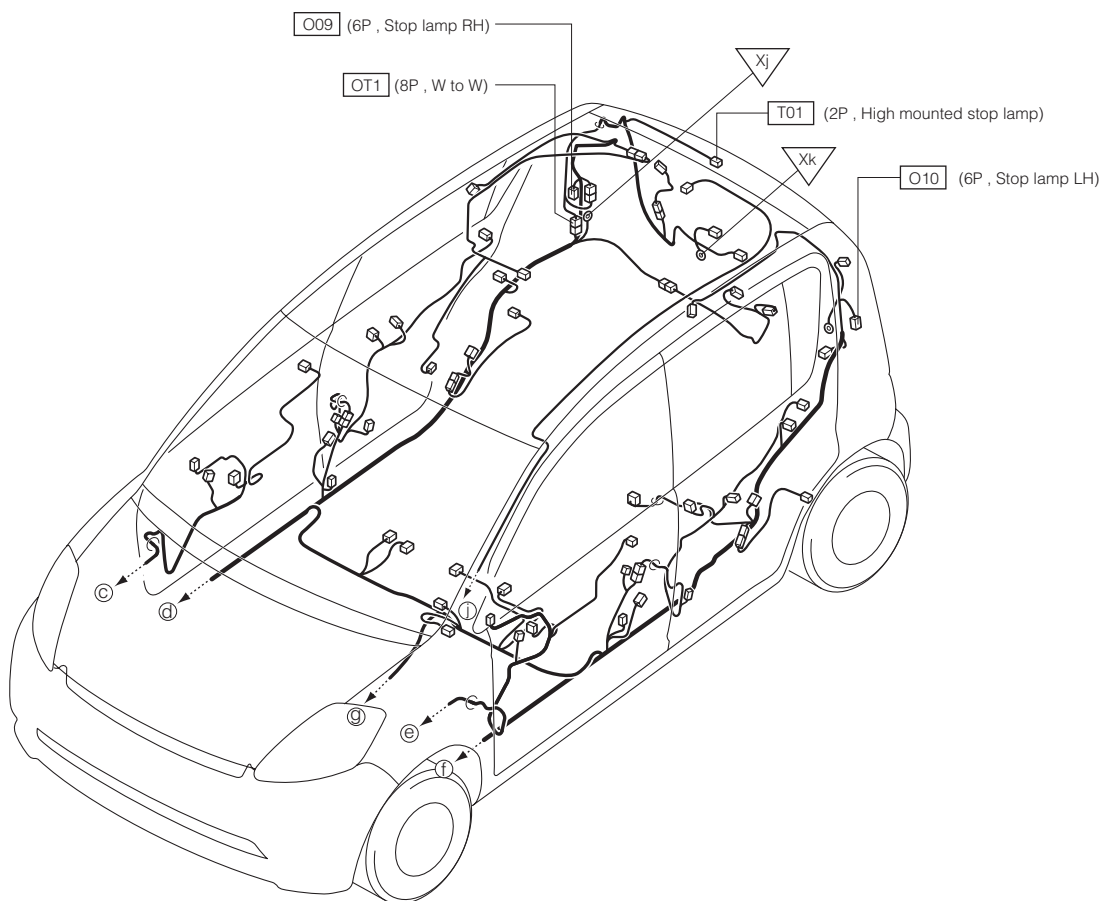
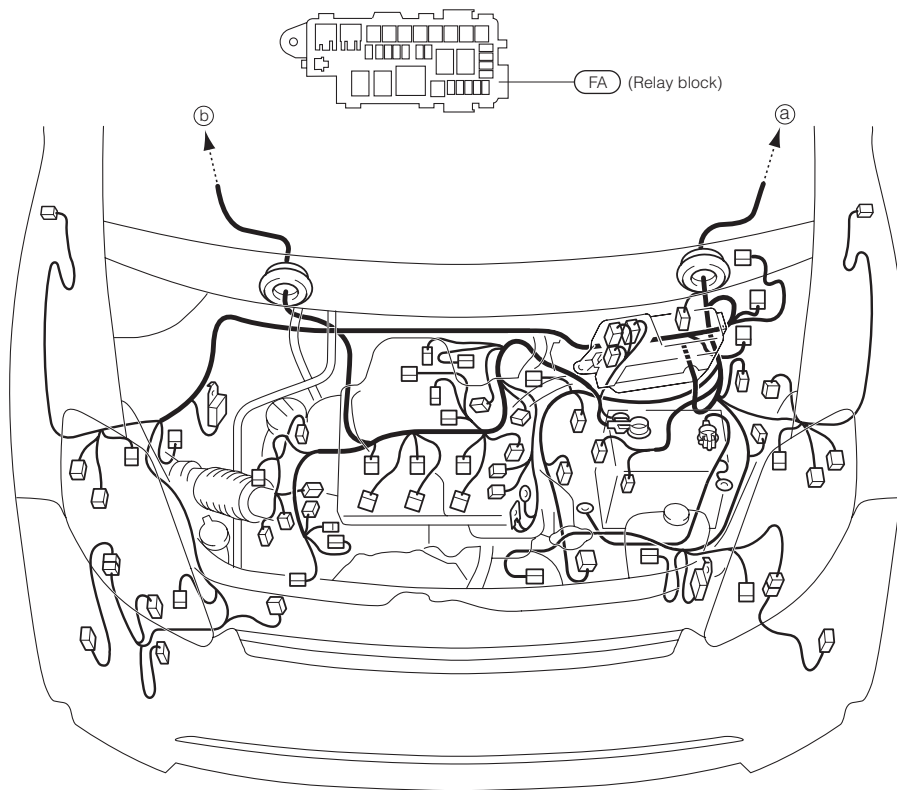

21 TAIL & LICENSE PLATE LAMP 21-1 RHD VEHICLE

*1:General export and AUS specification
*2:Except General export and AUS specification

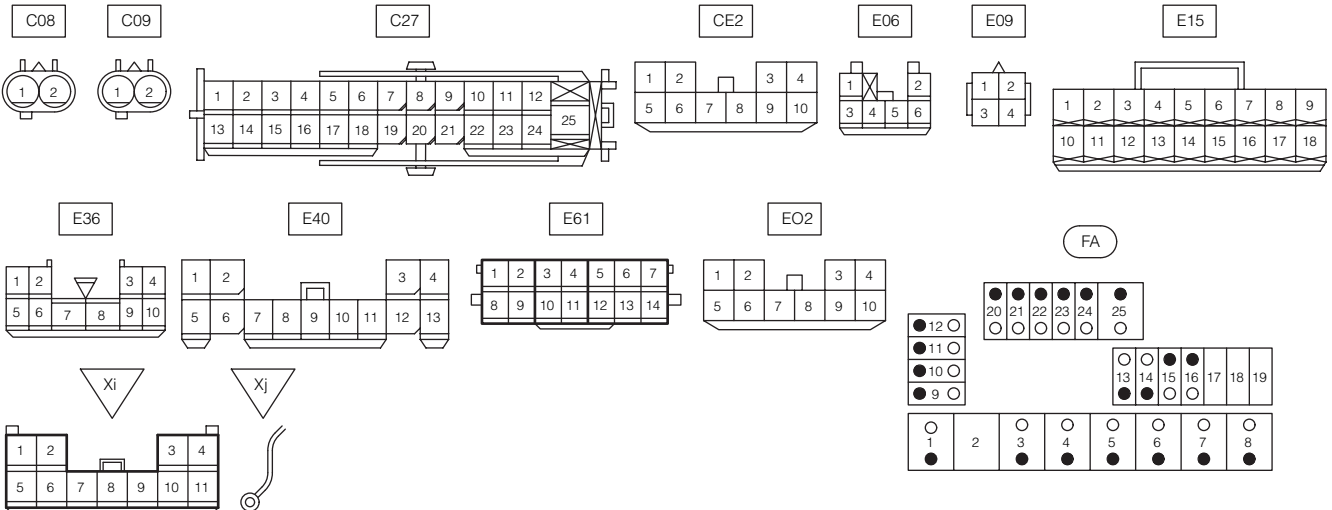
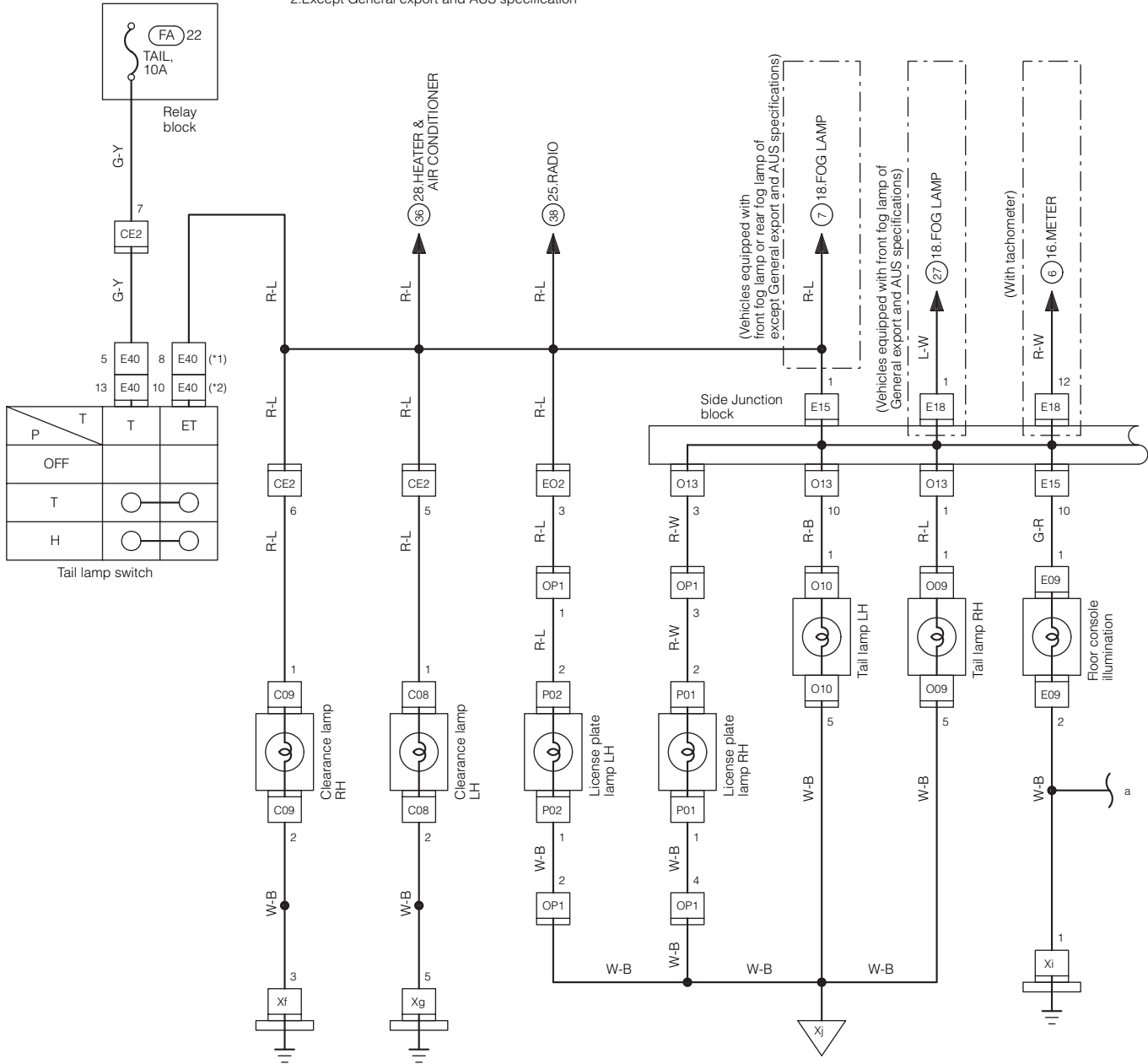

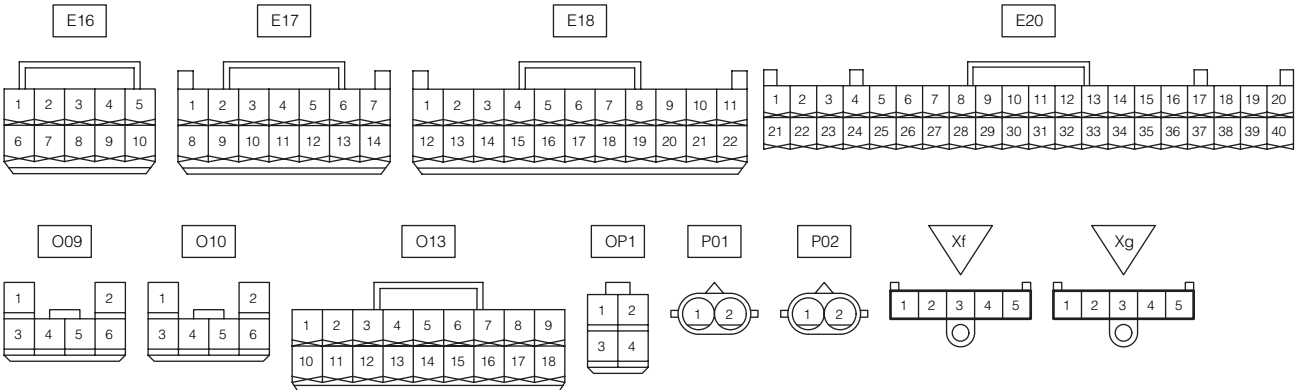
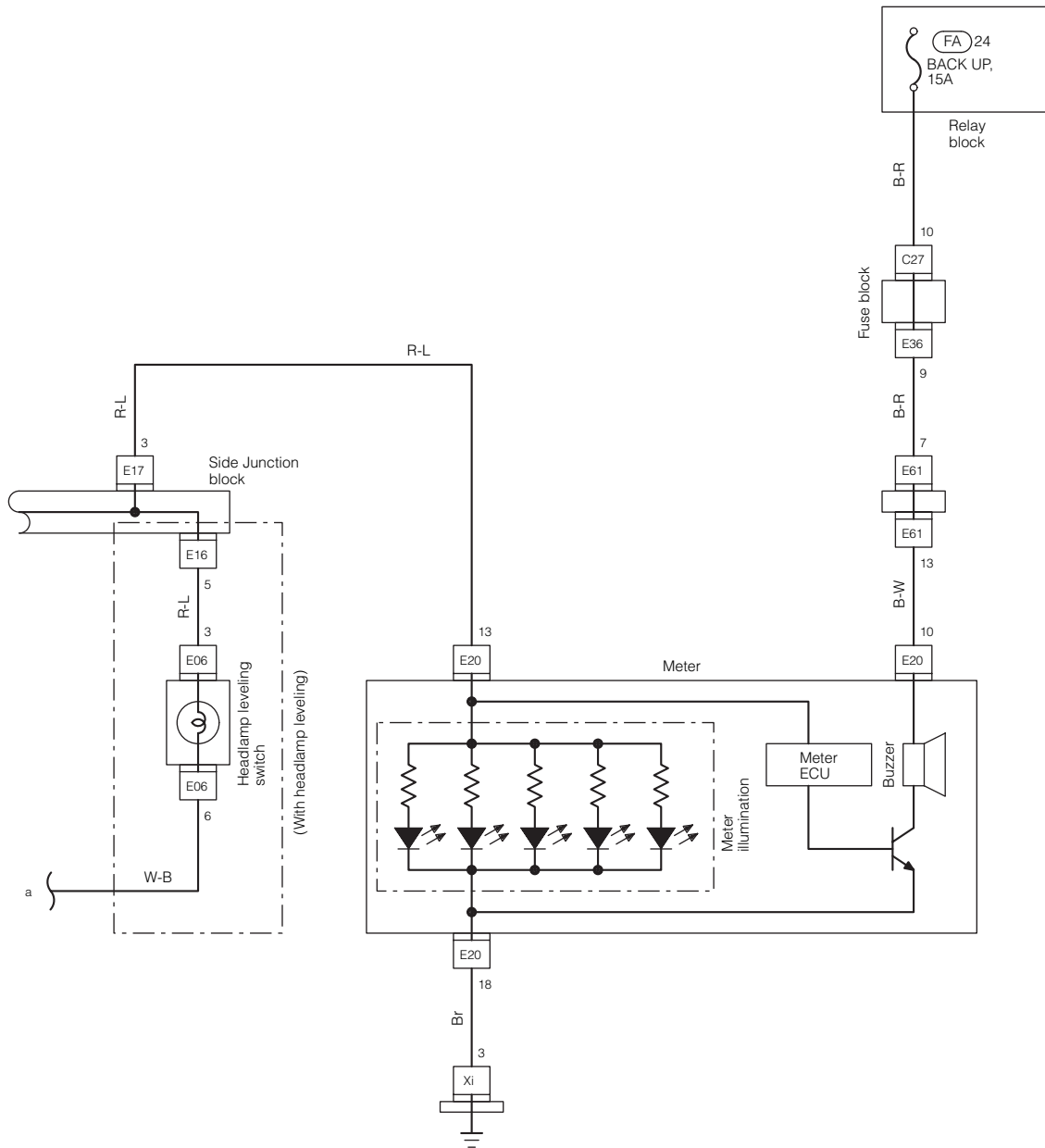

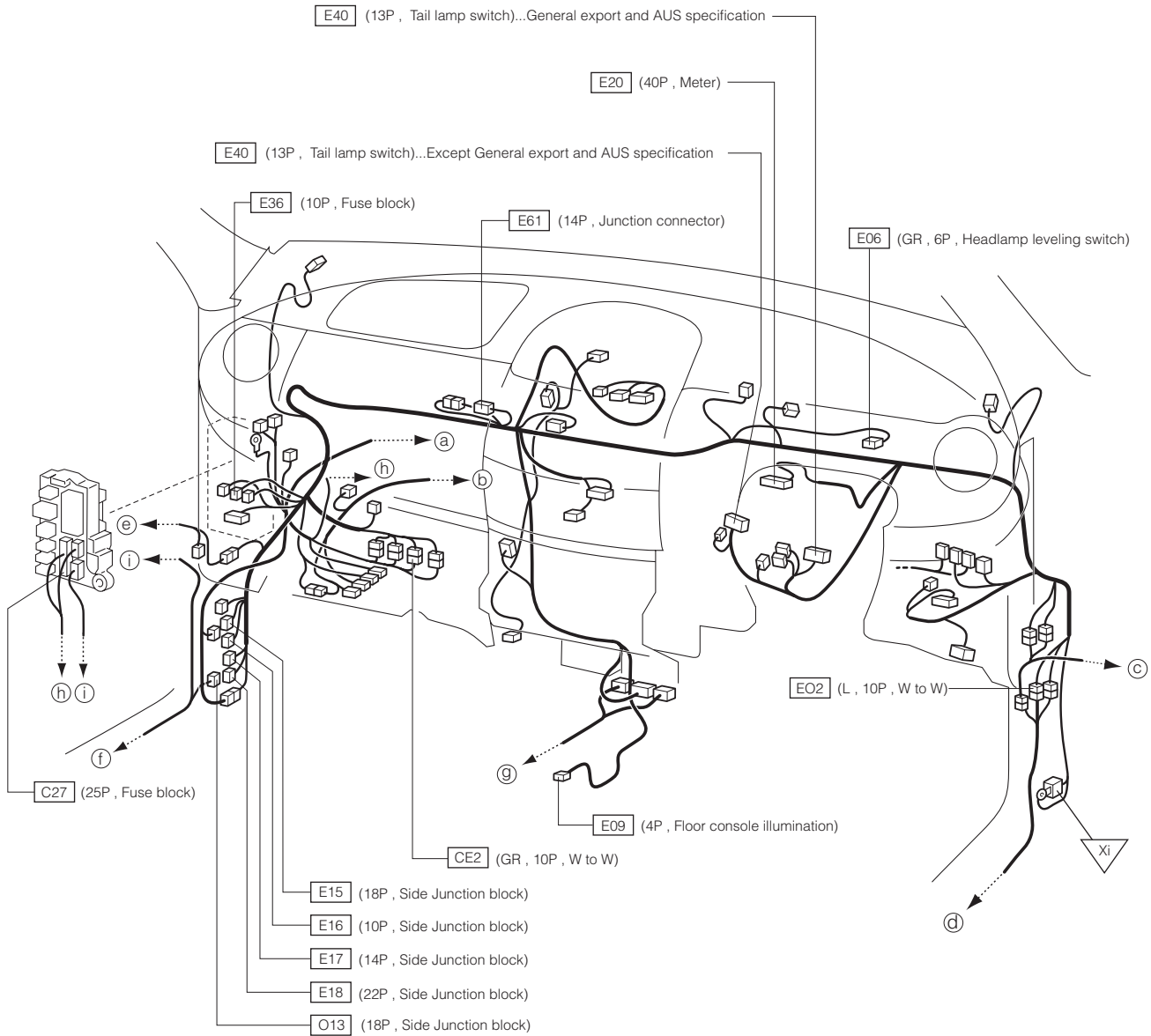

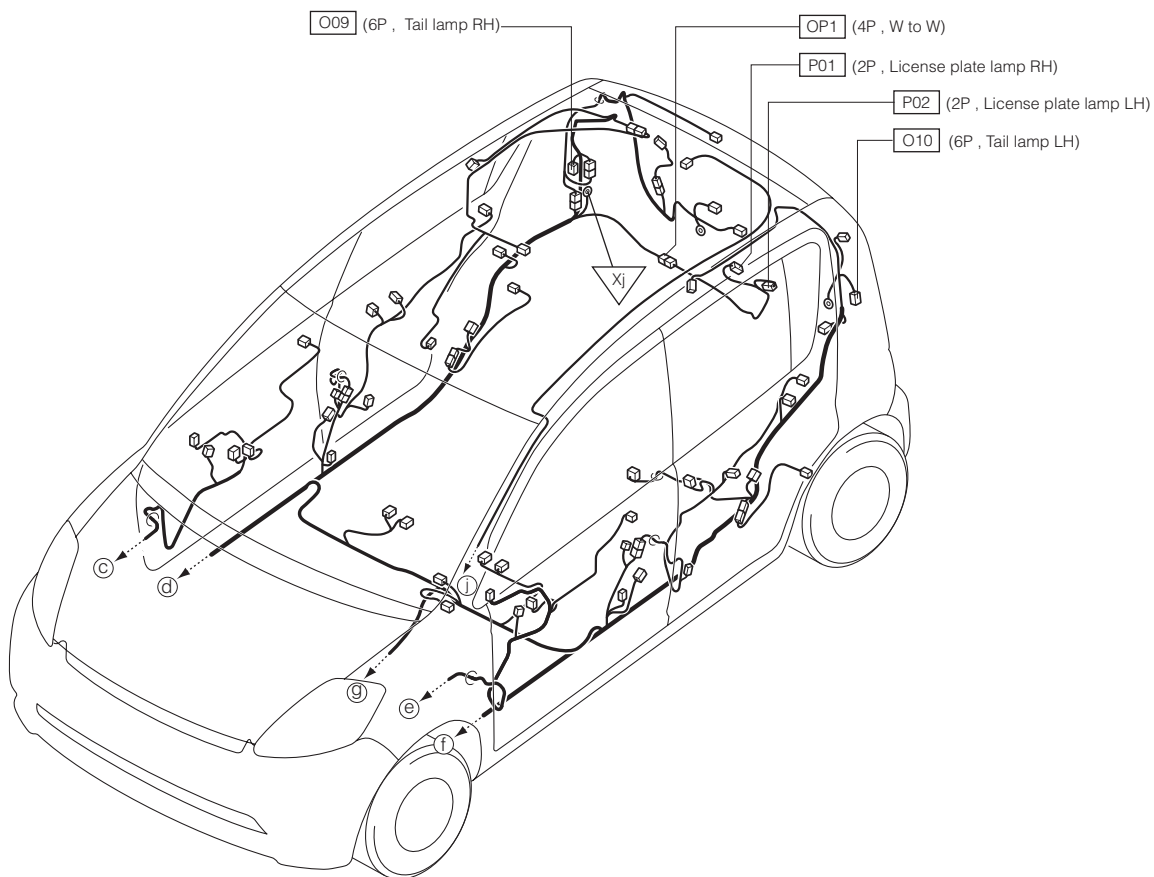
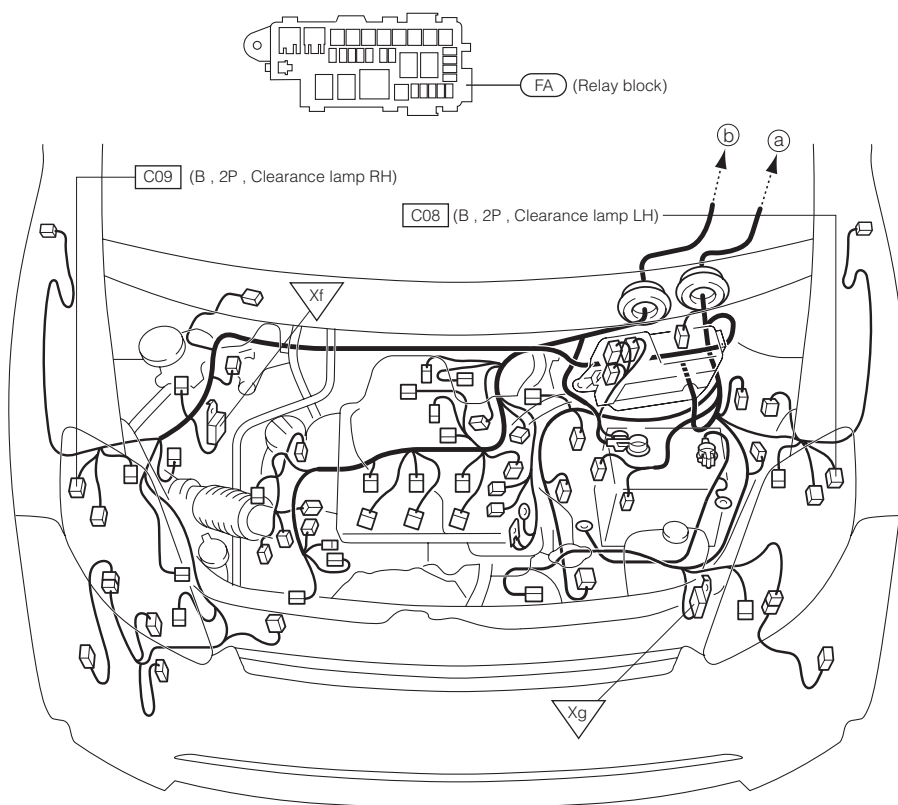

21-2 LHD VEHICLE

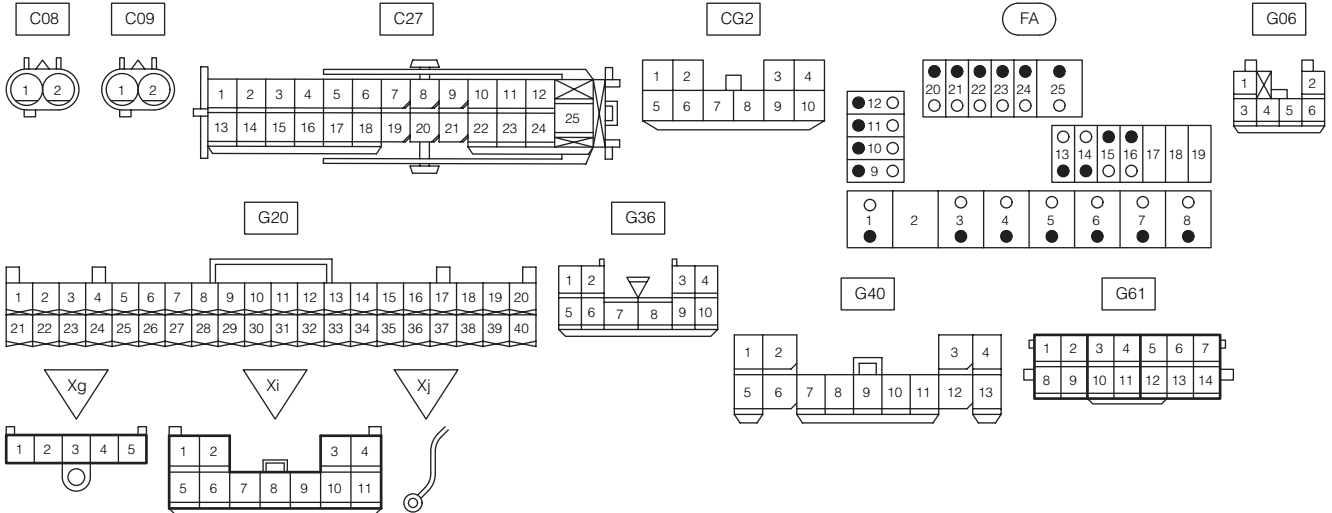
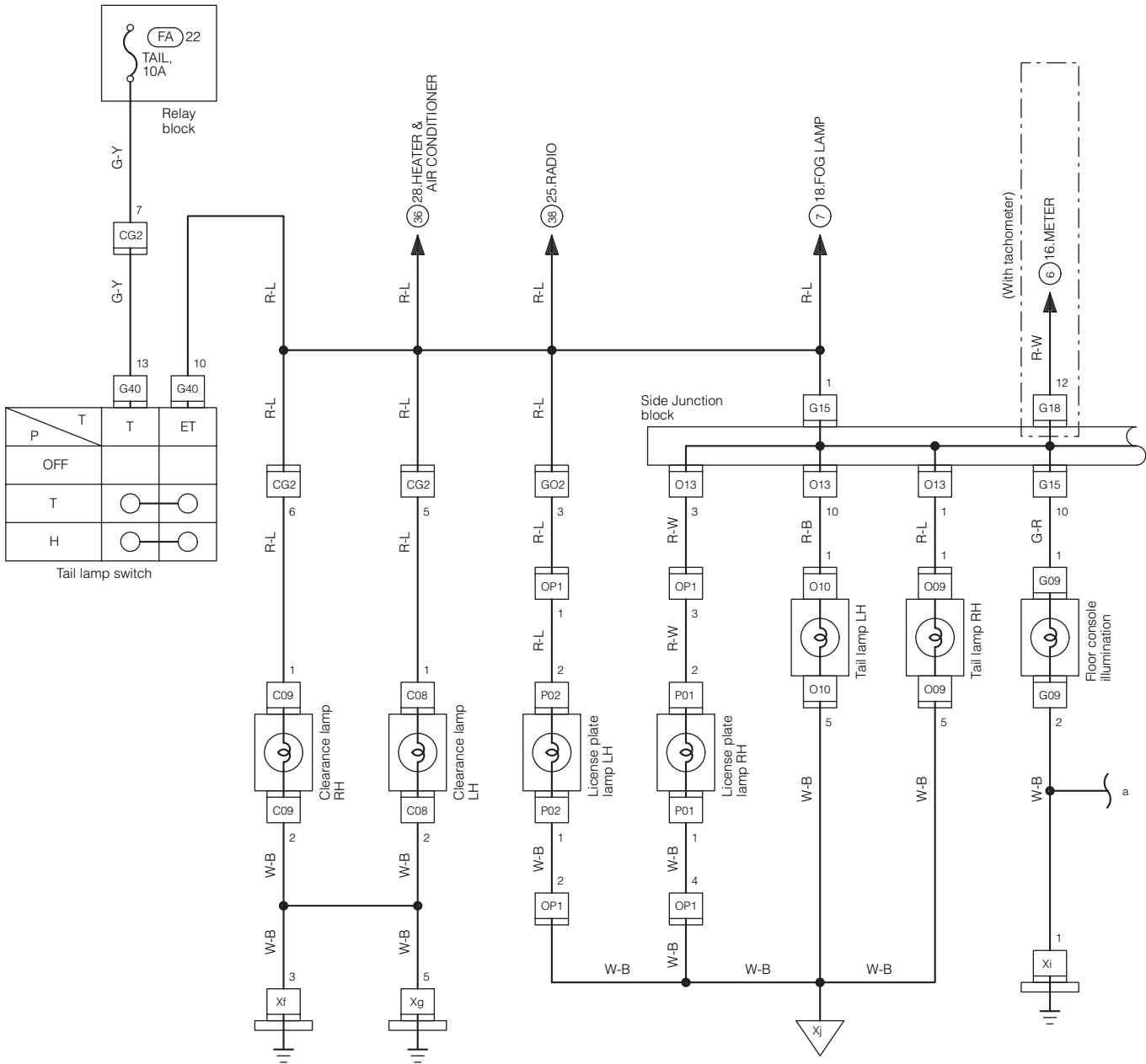

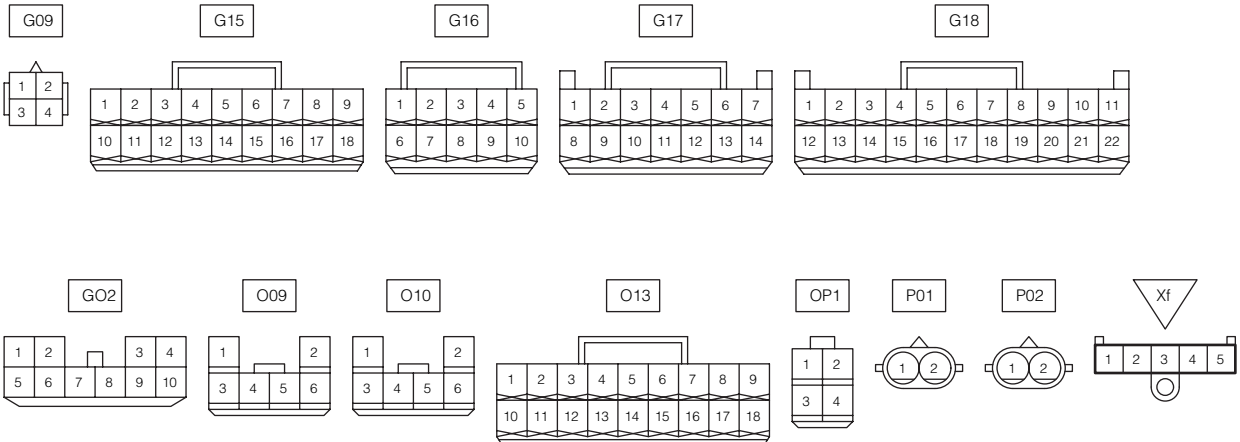
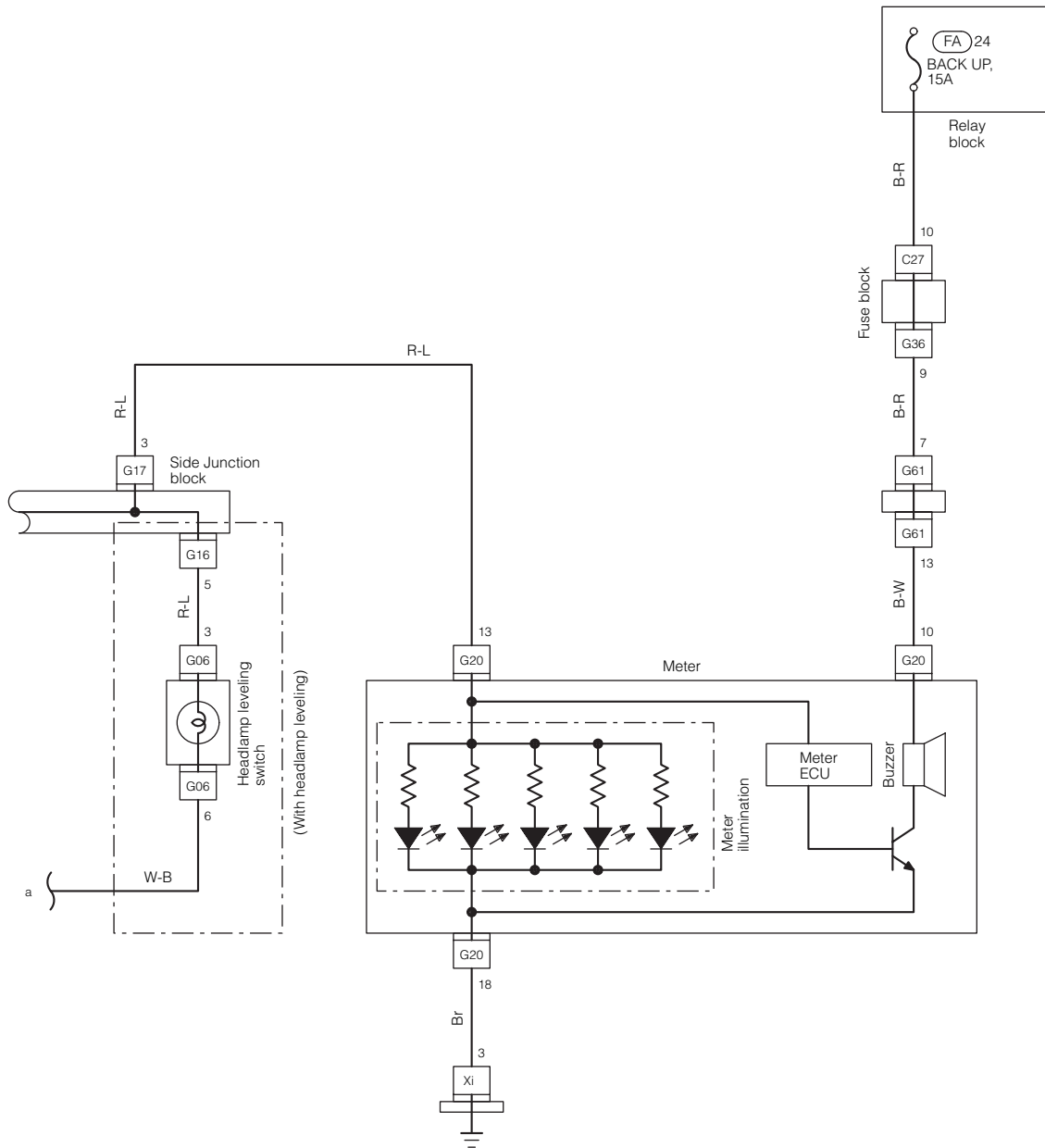

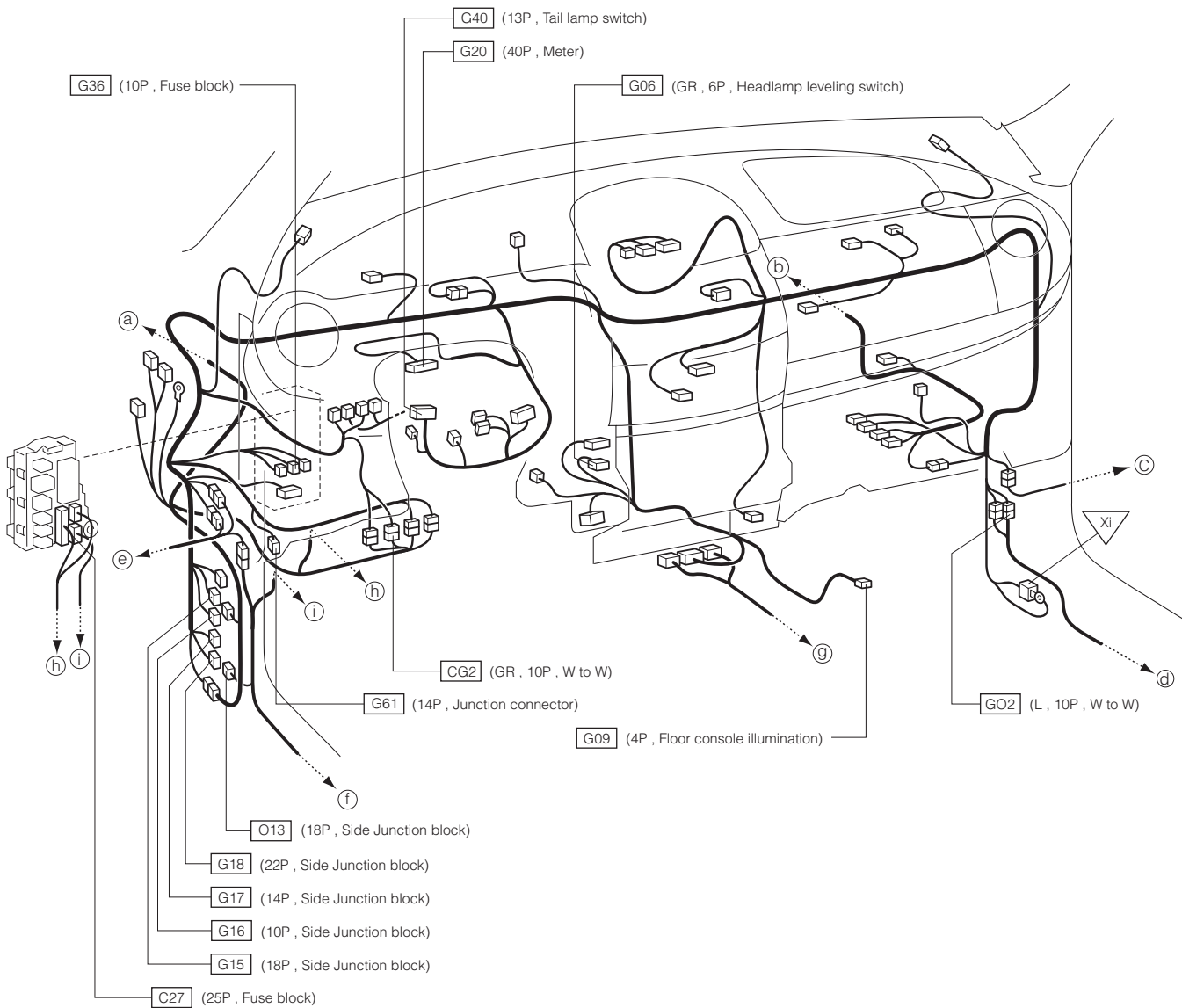

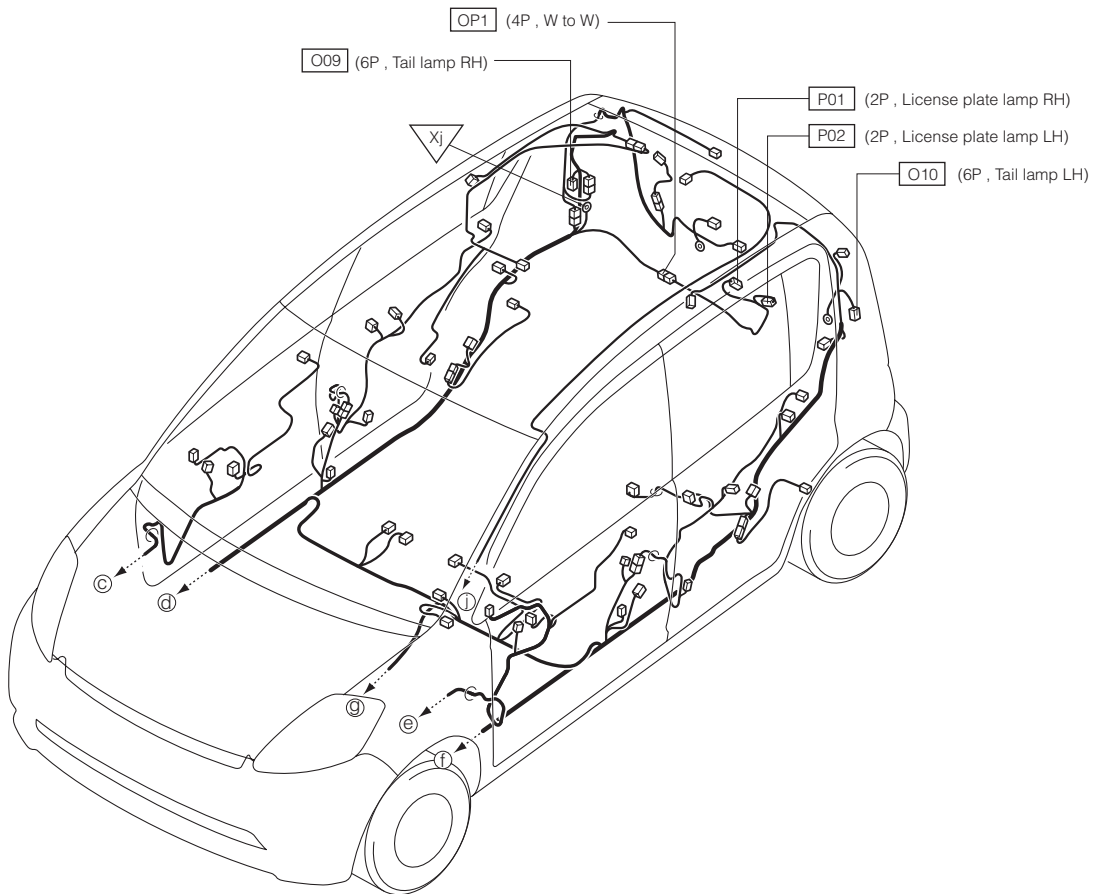
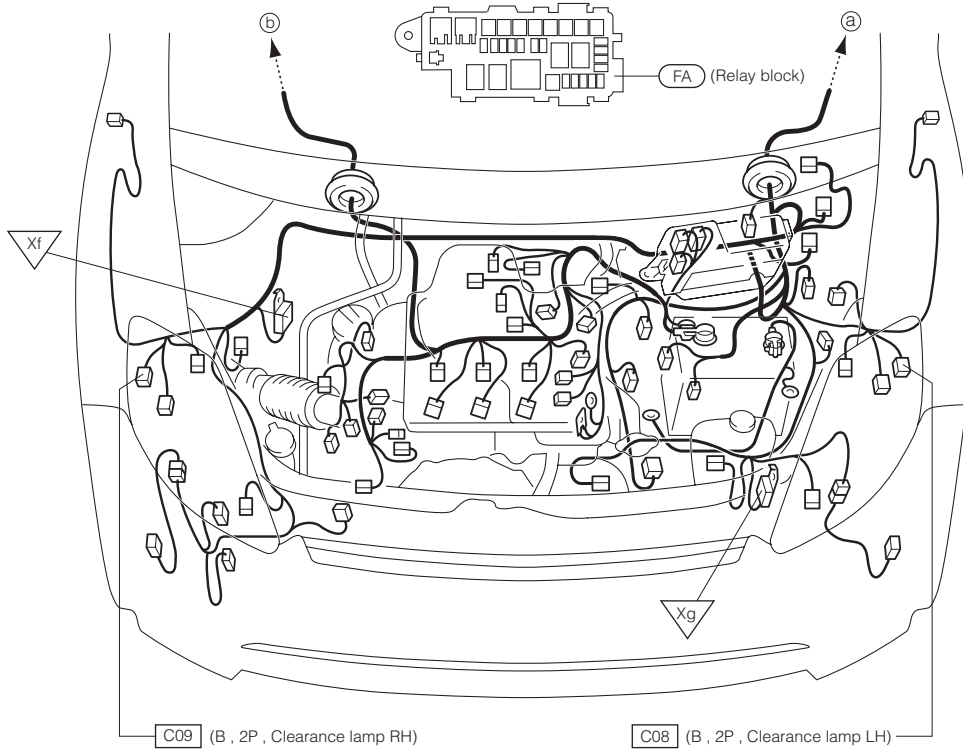

22 BACK UP LAMP 22-1 RHD VEHICLE

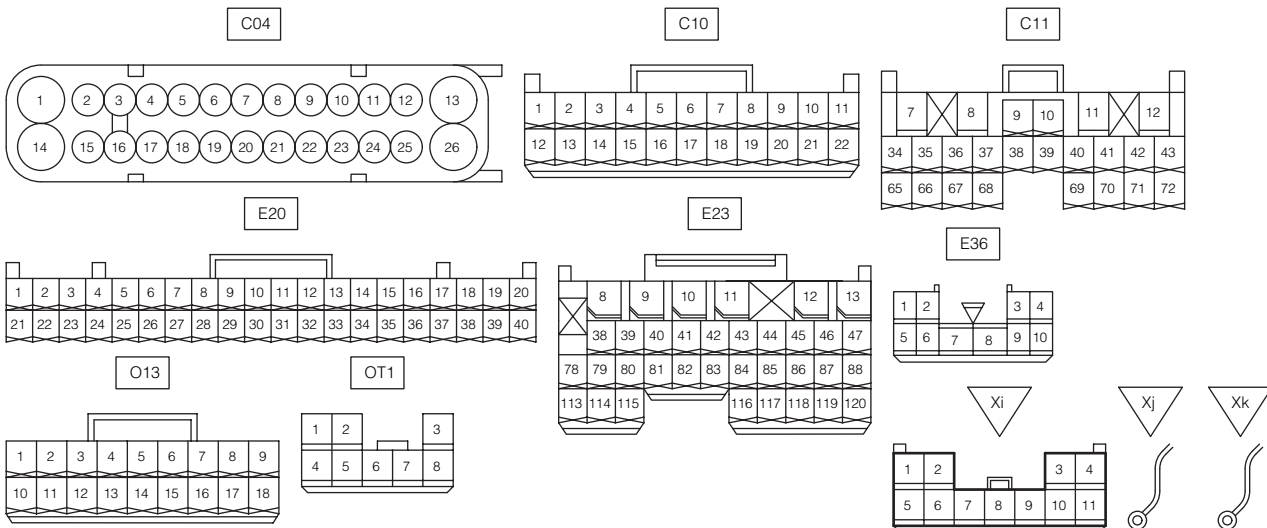
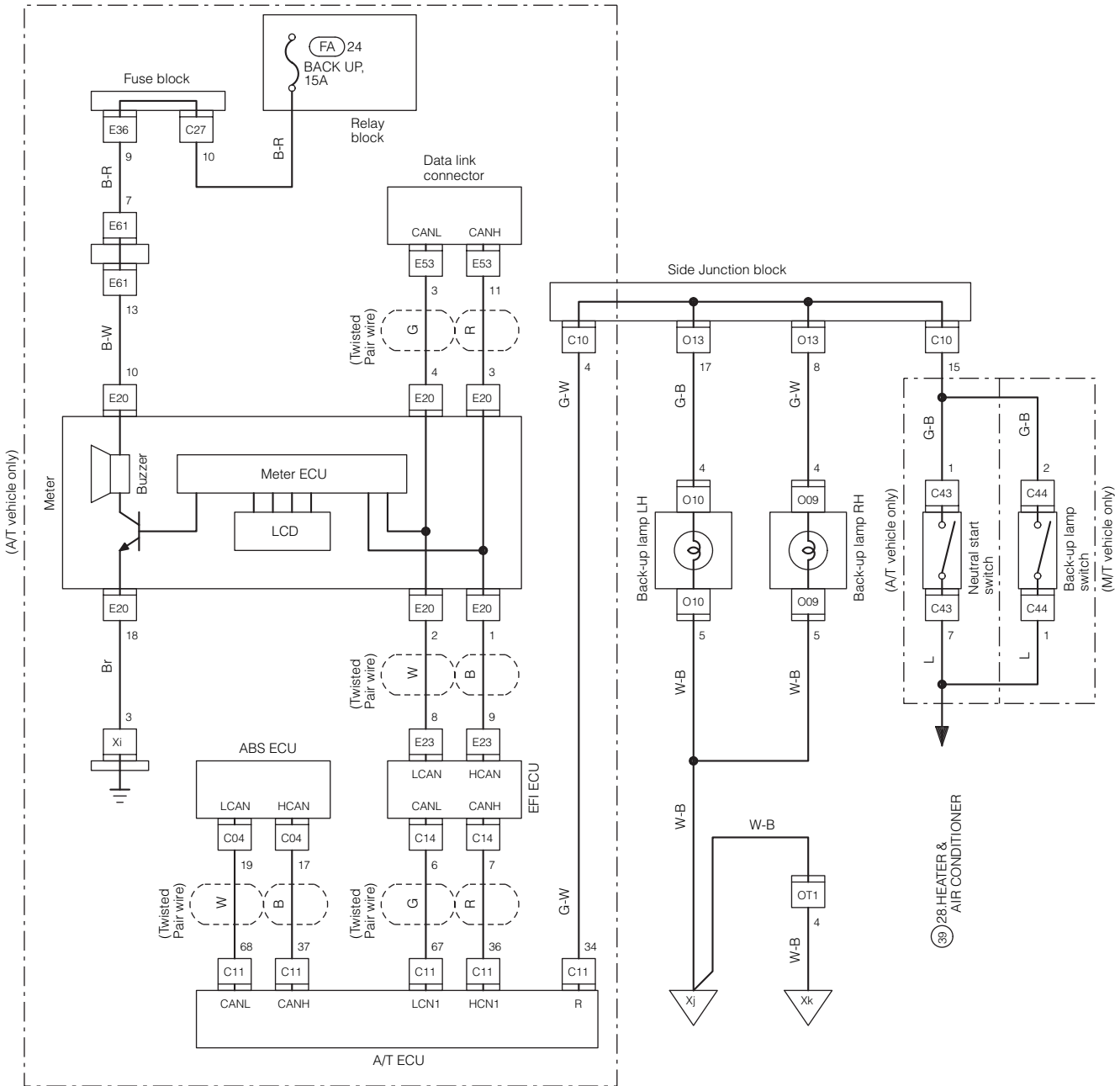

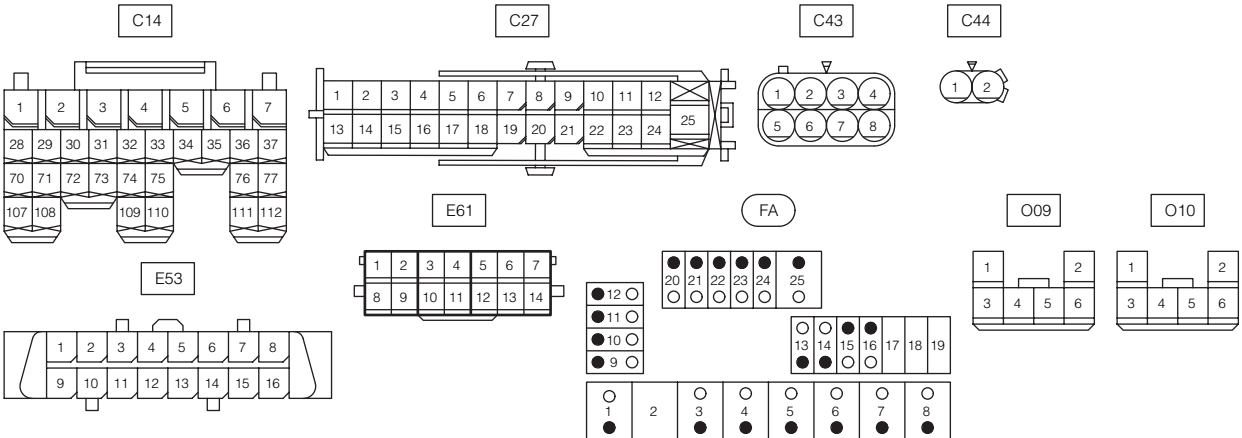

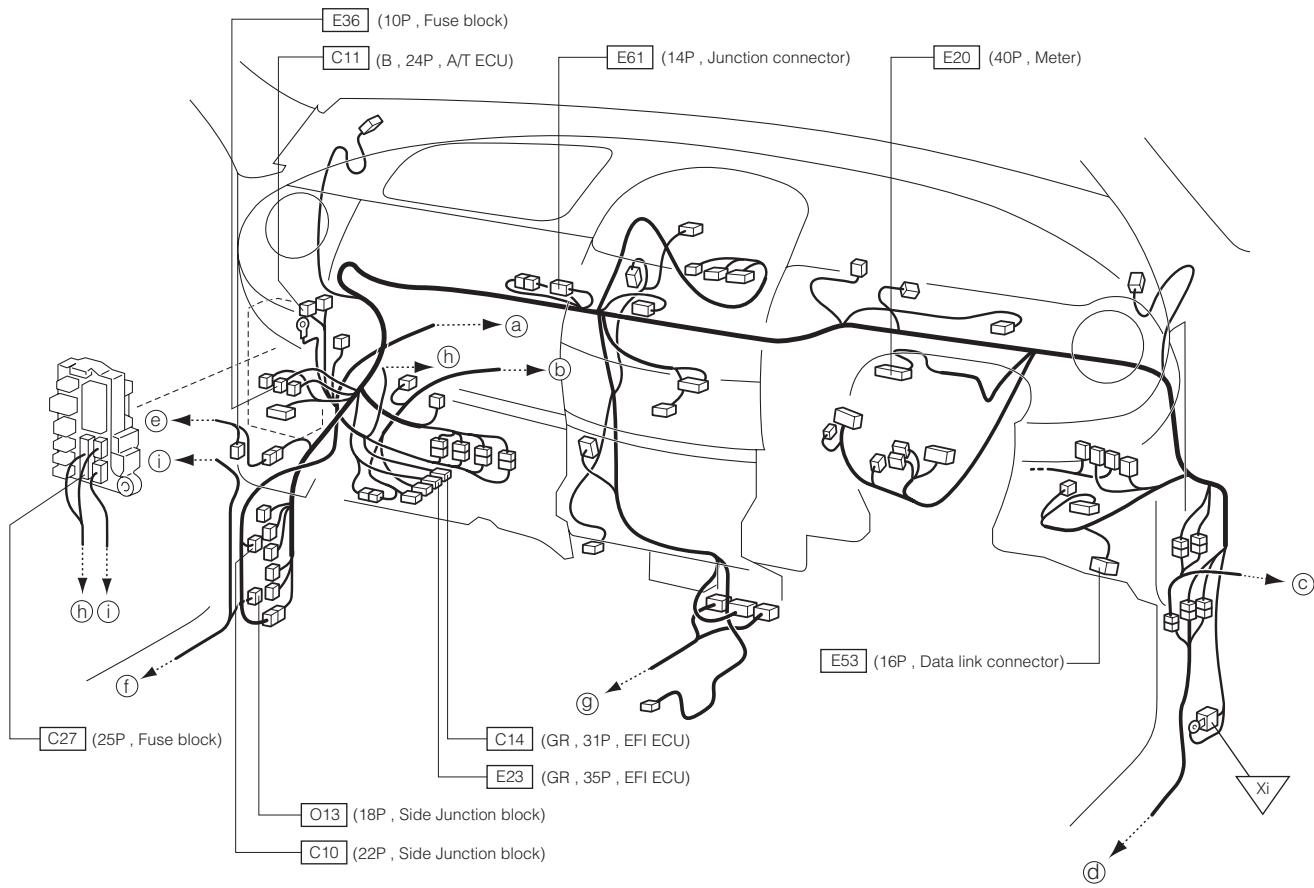

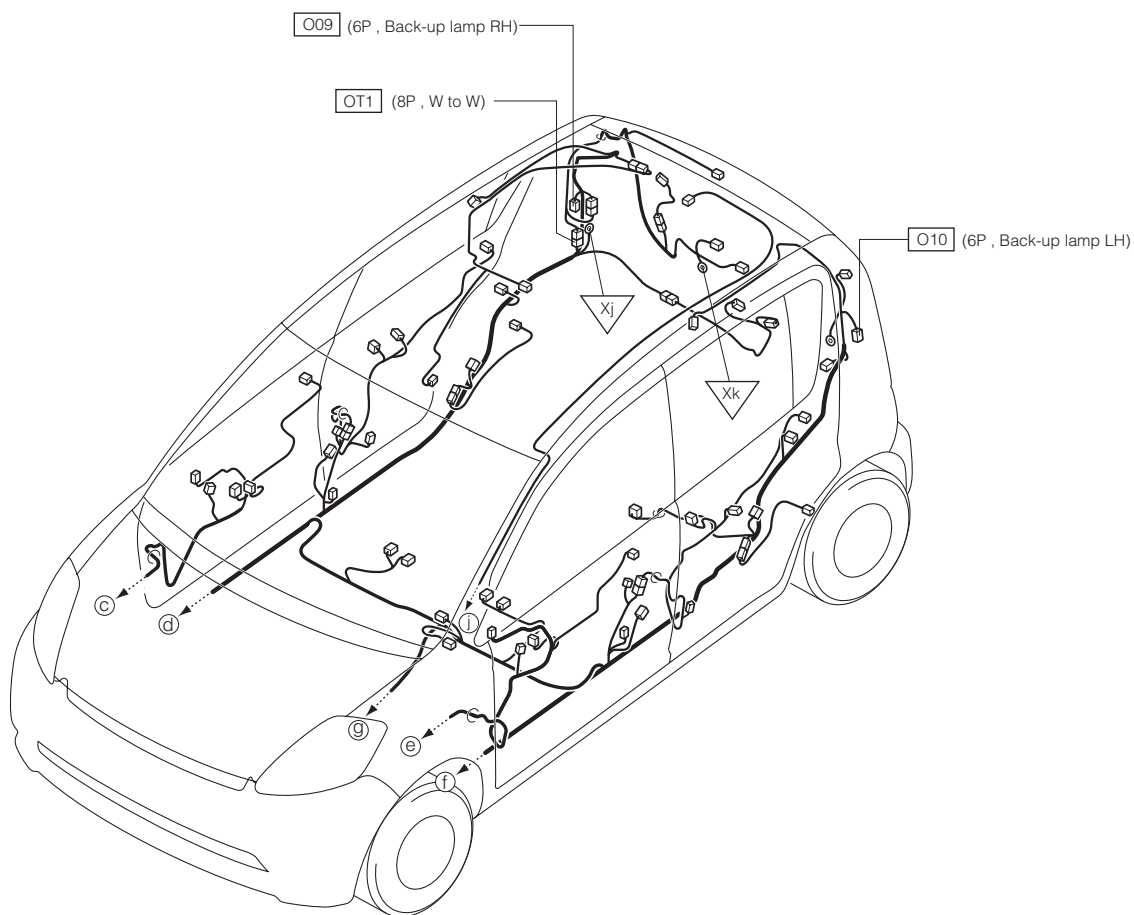
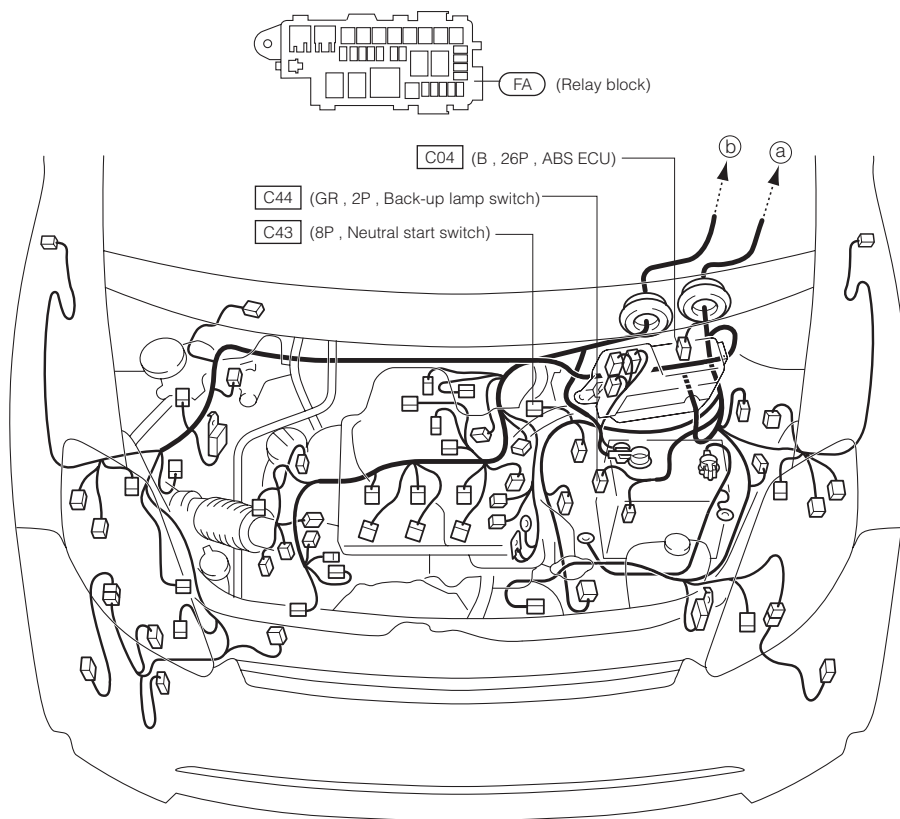

22-2 LHD VEHICLE

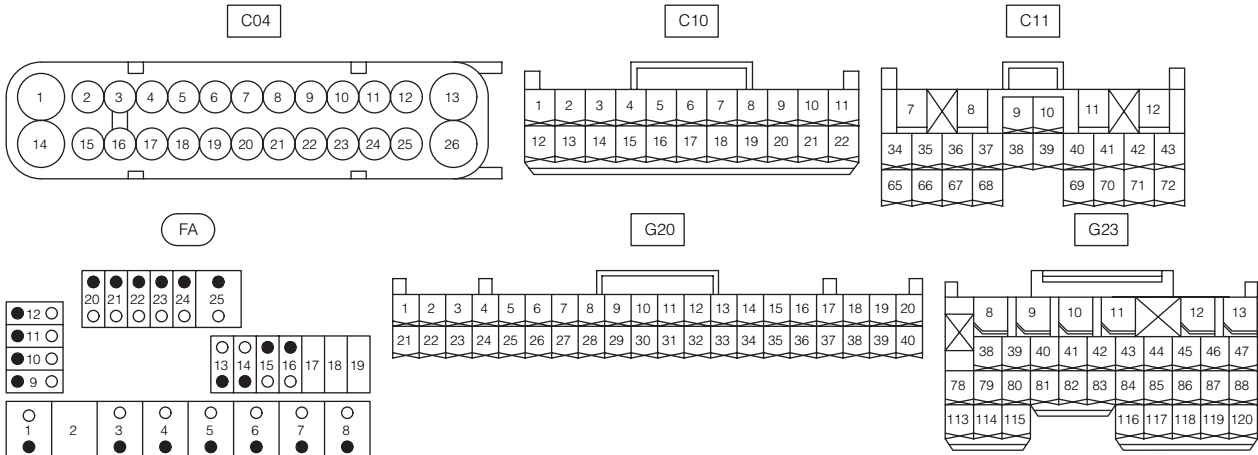
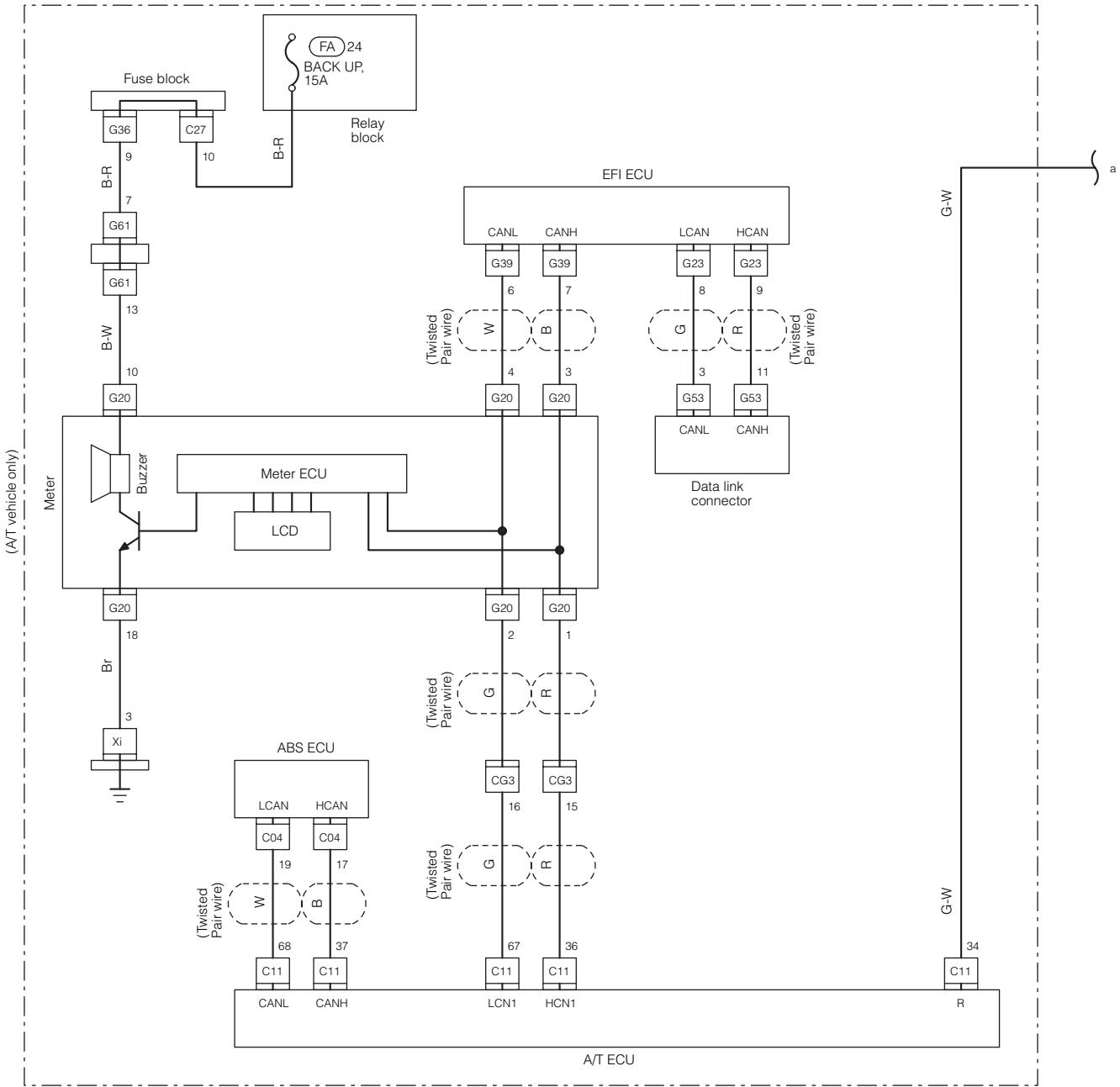

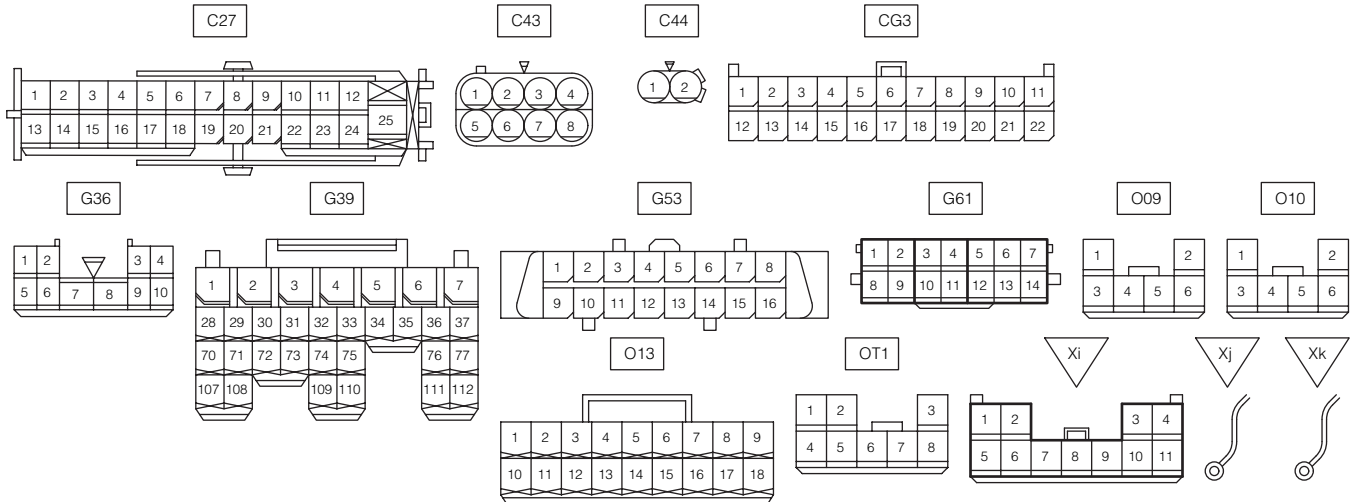
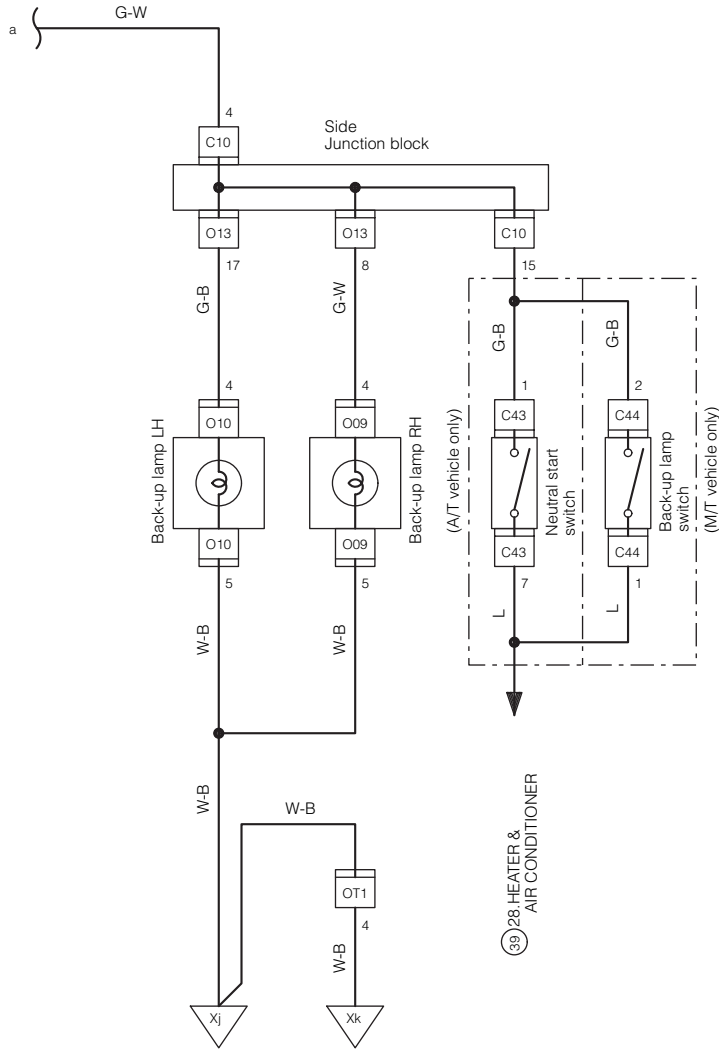

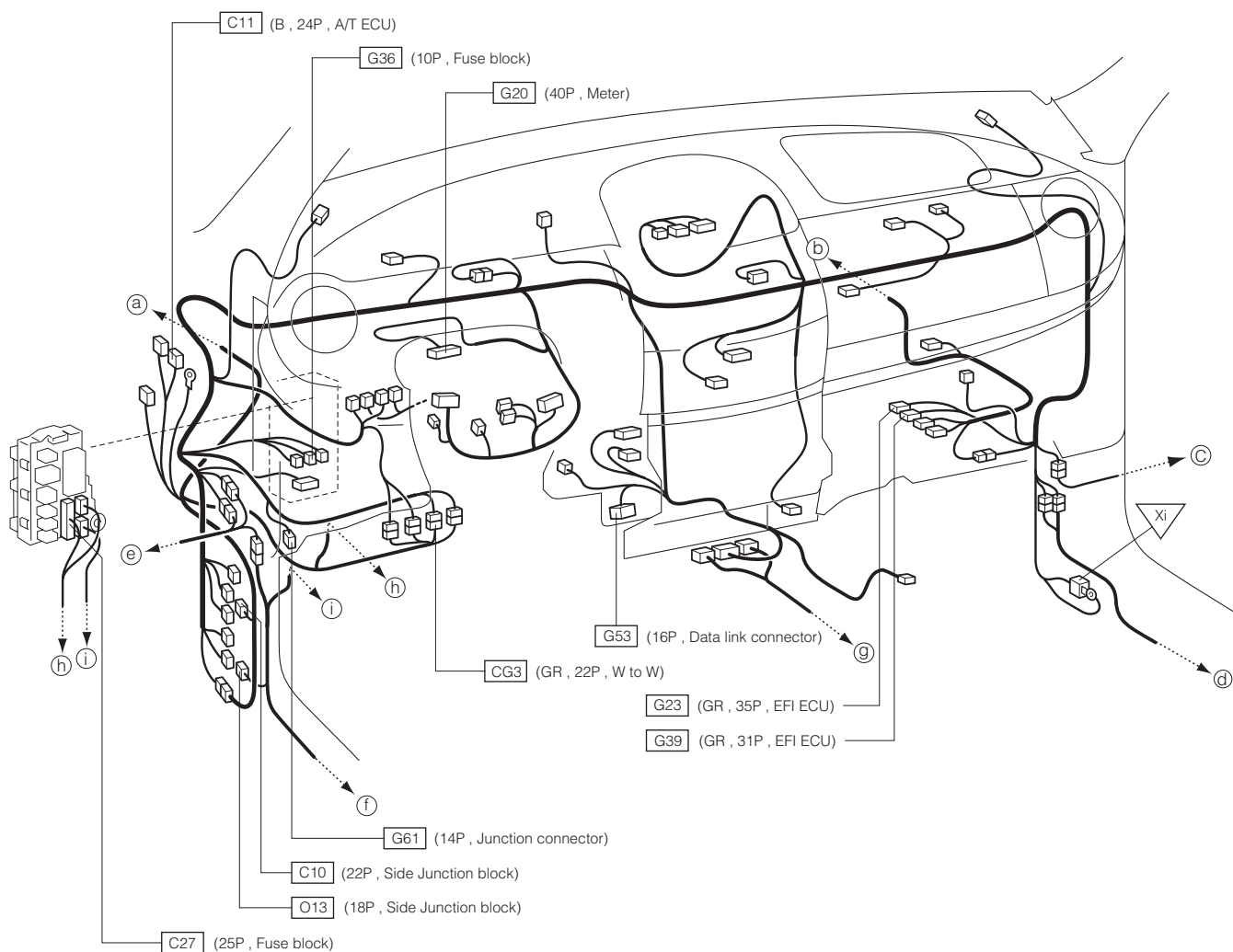

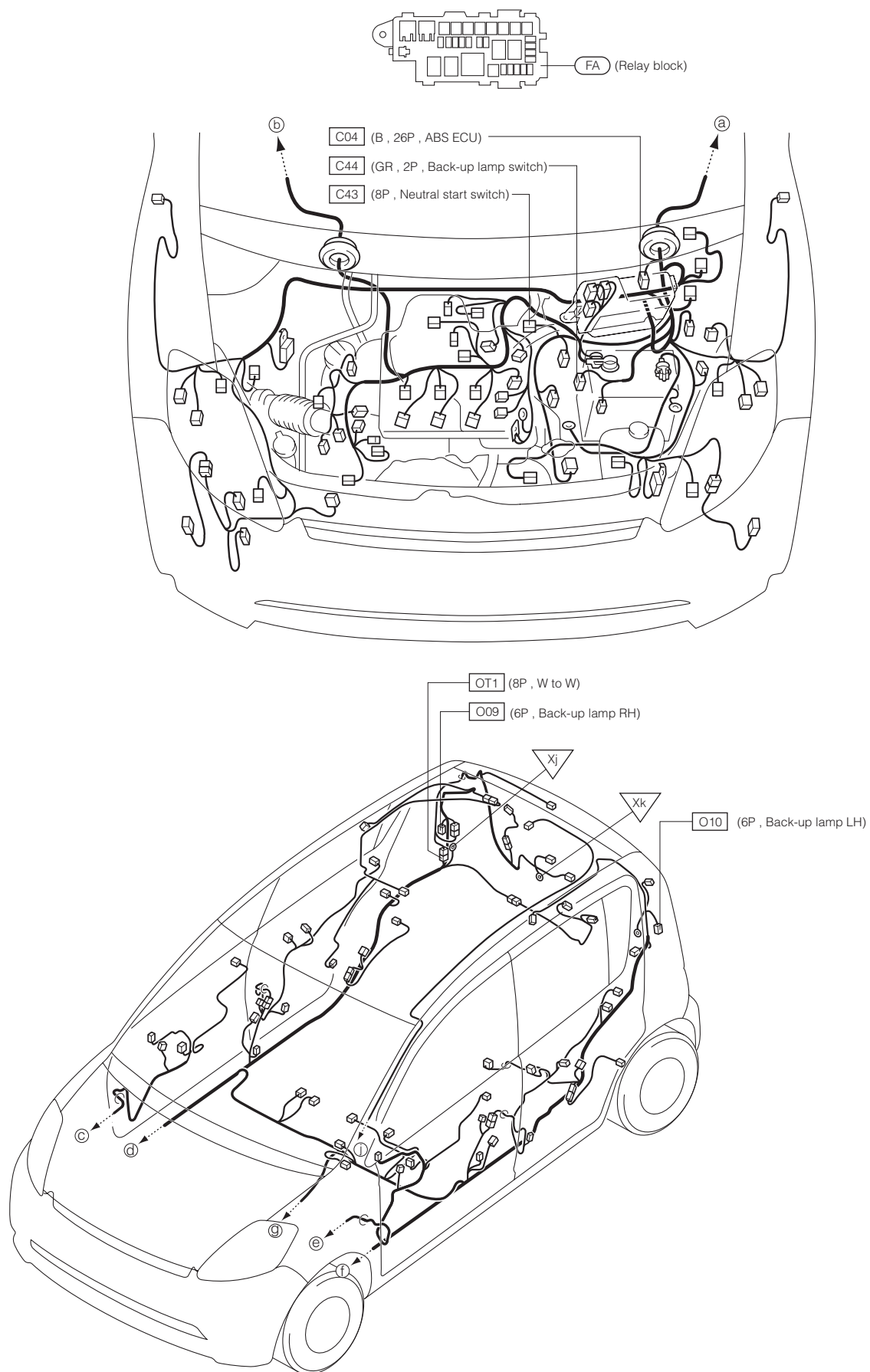

23 FRONT WIPER & WASHER 23-1 RHD VEHICLE

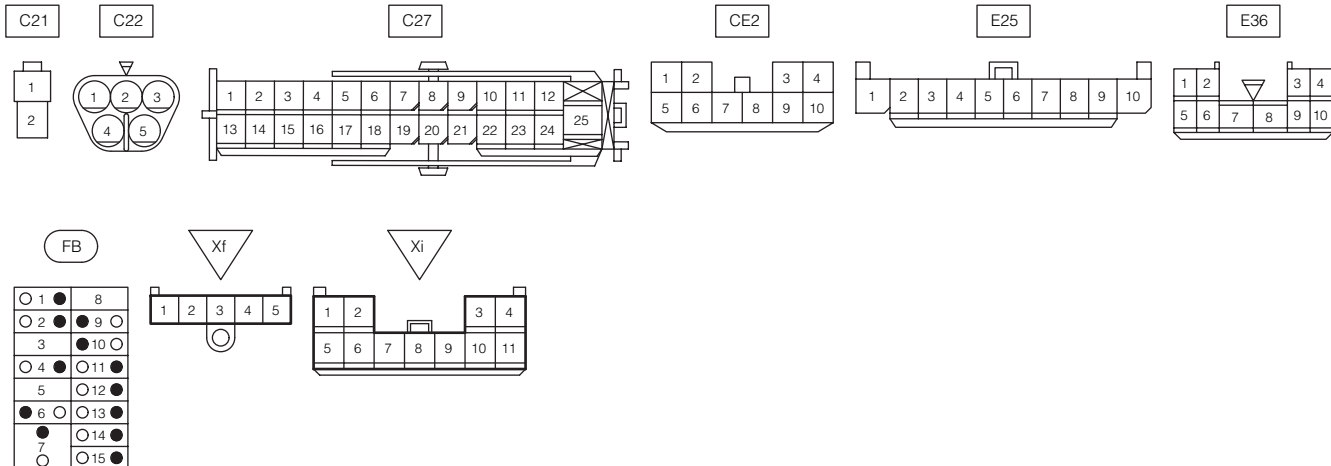
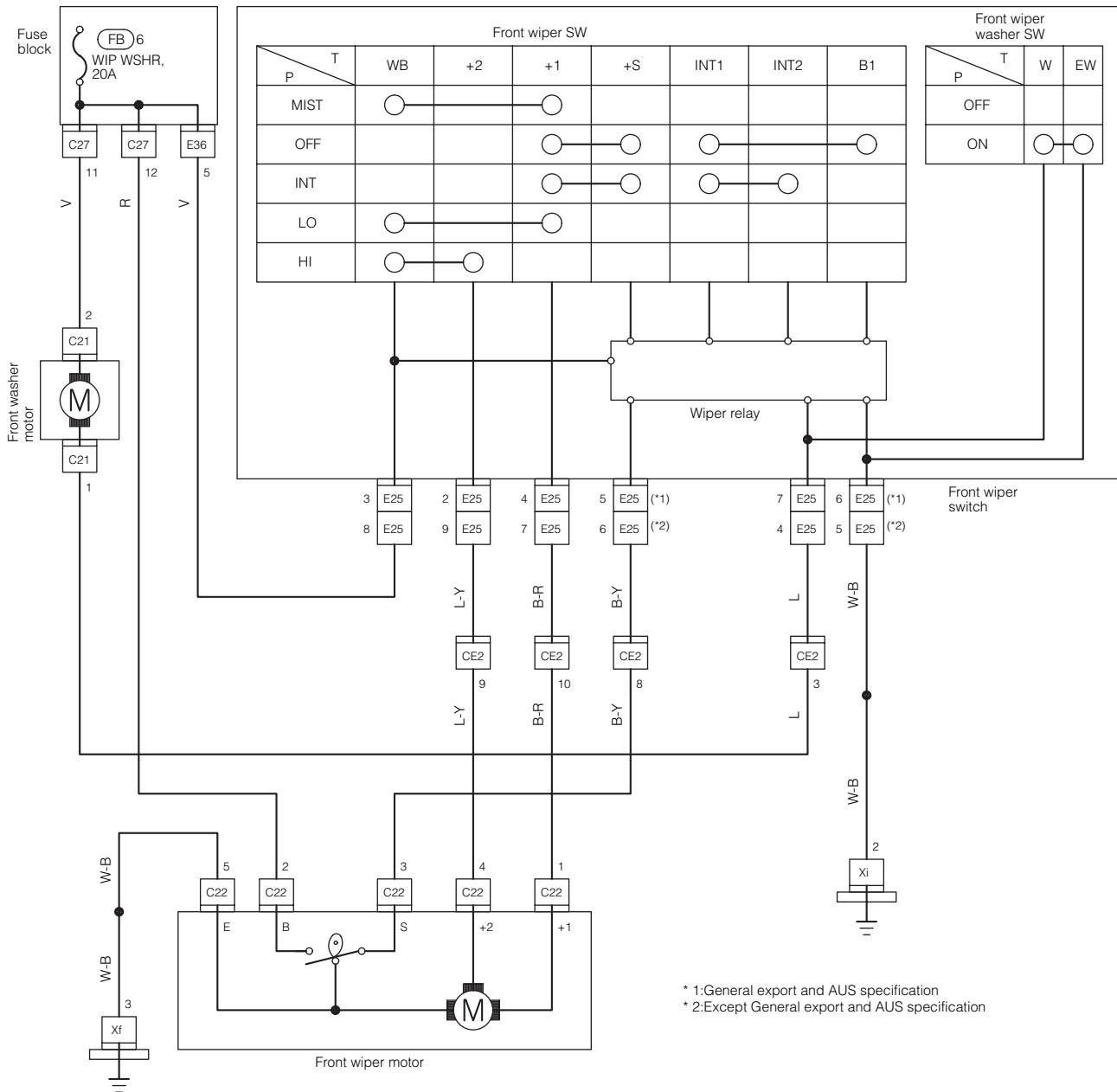

(MEMO)

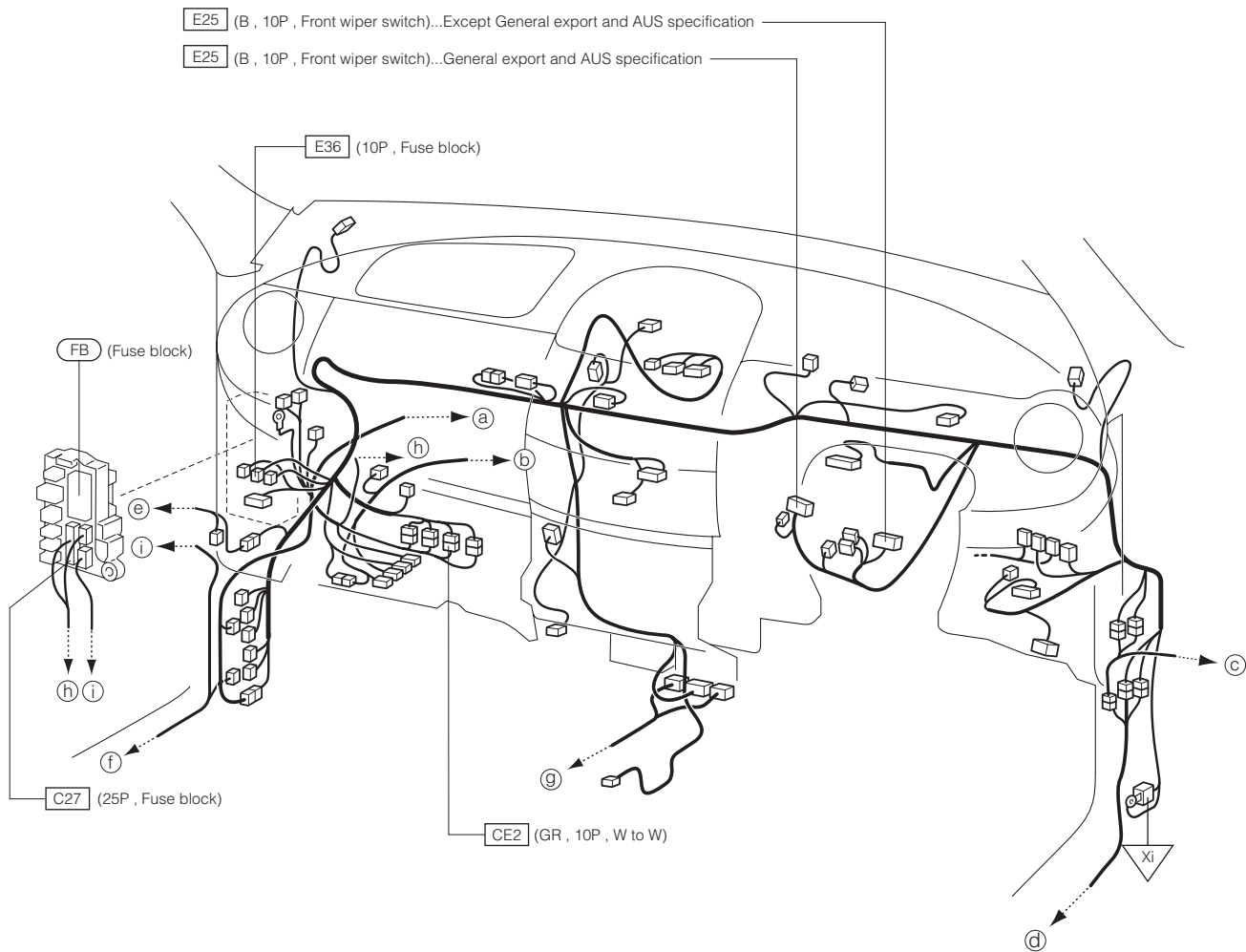

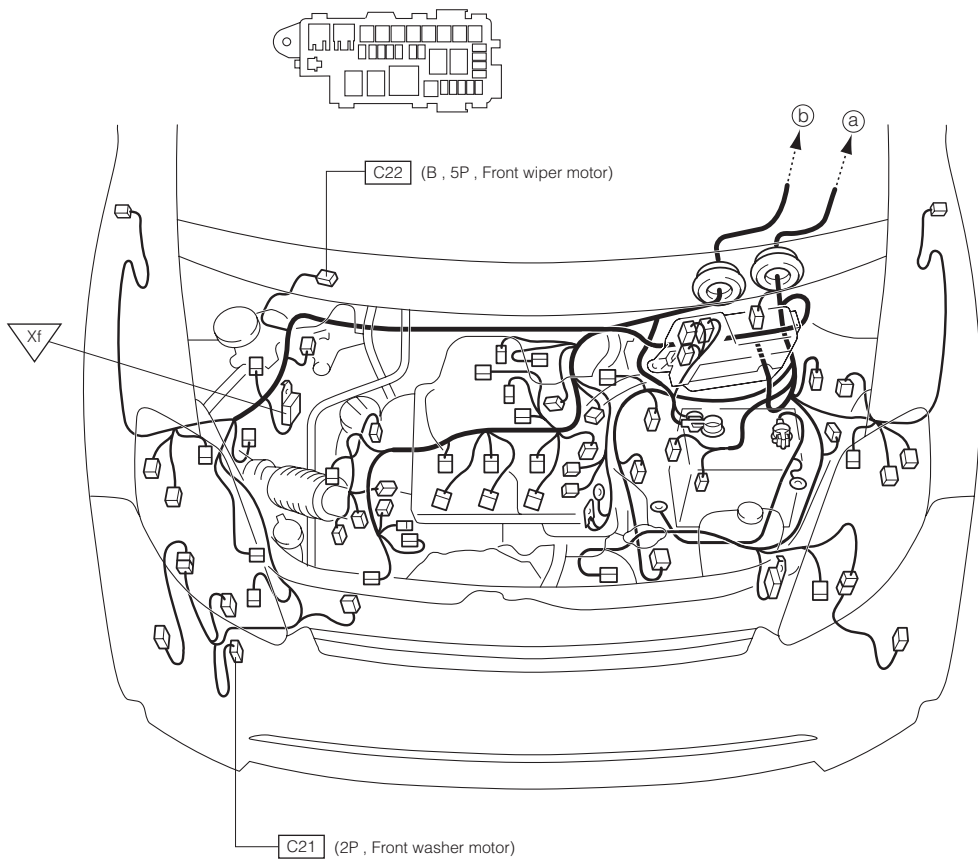

23-2 LHD VEHICLE

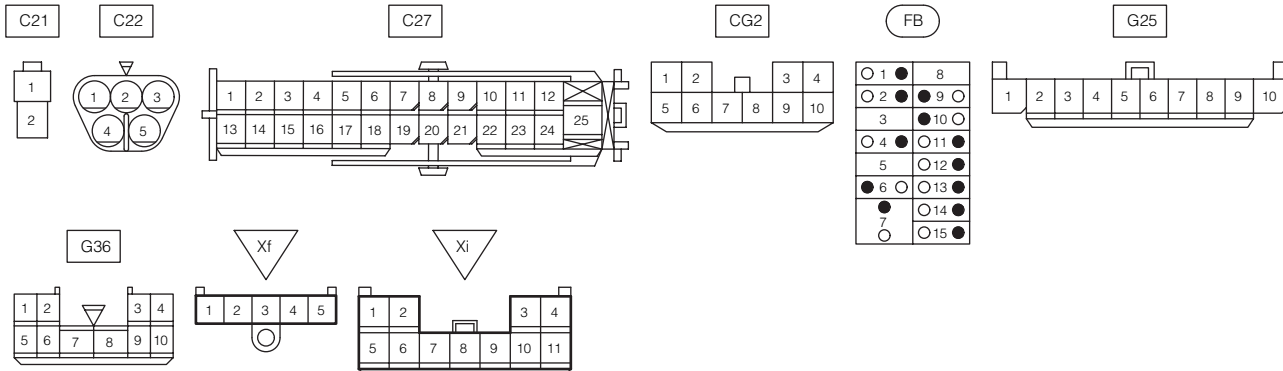
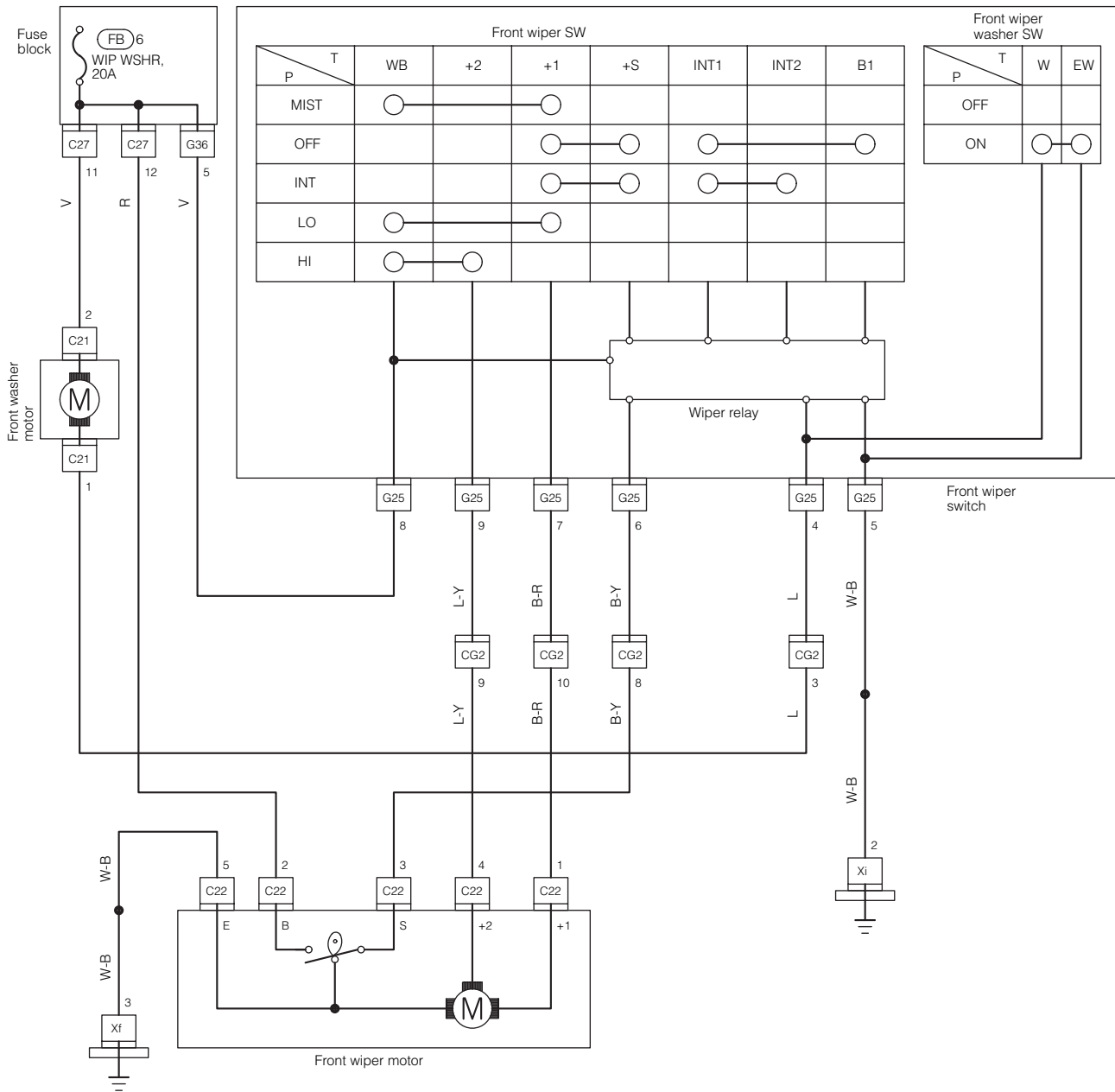

(MEMO)

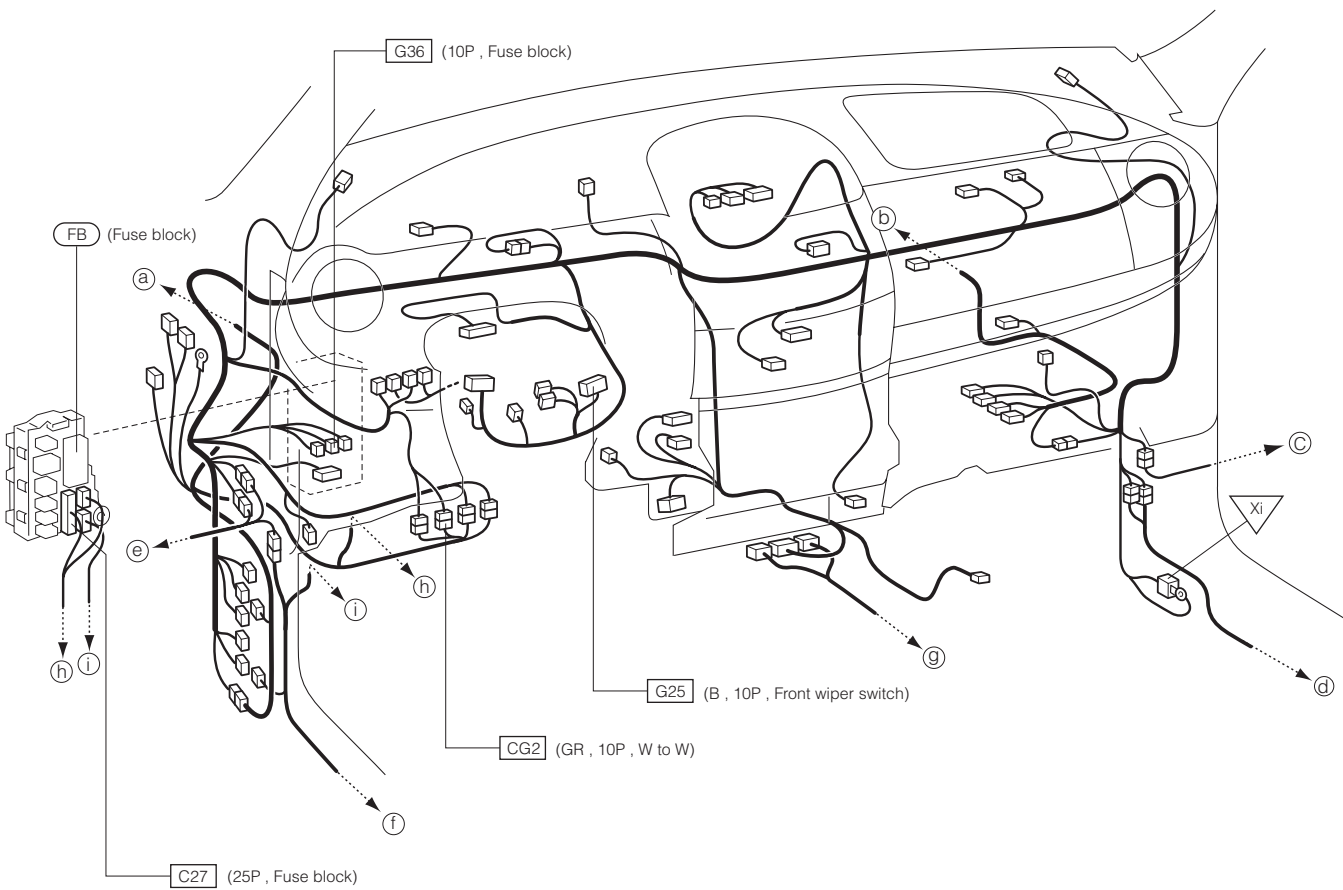

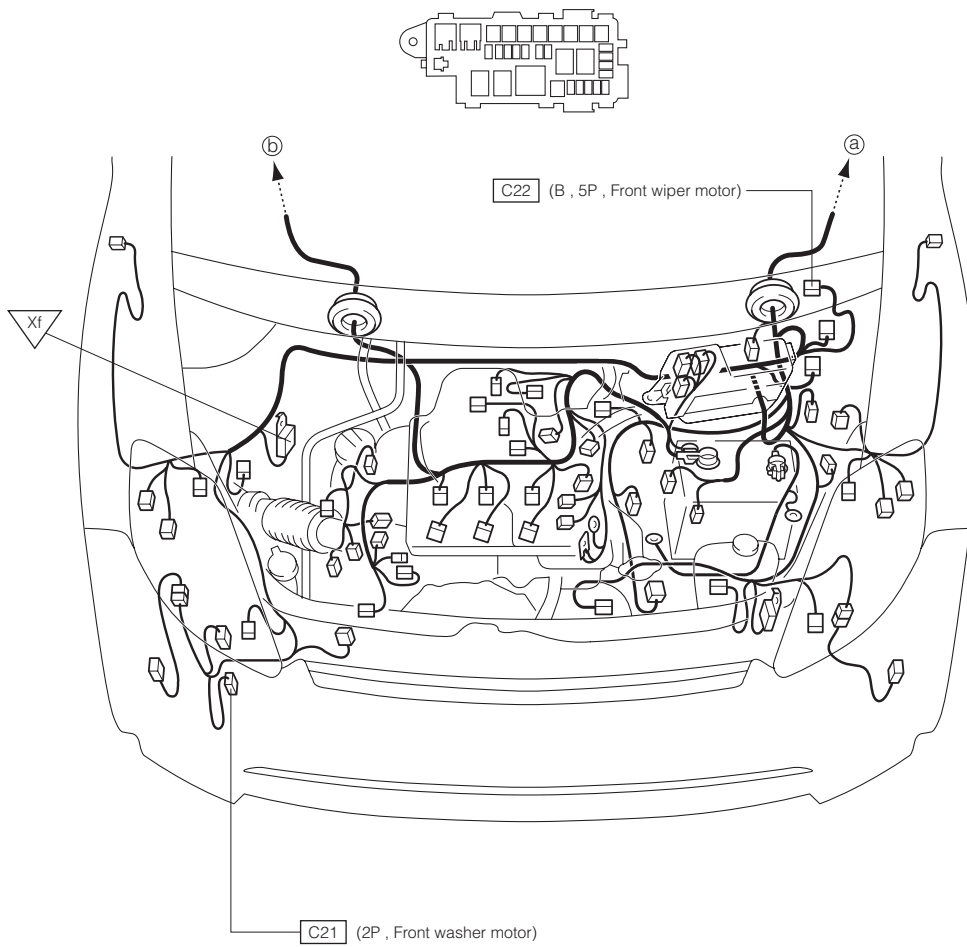

24 REAR WIPER & WASHER 24-1 RHD VEHICLE(WITH INT SYSTEM)

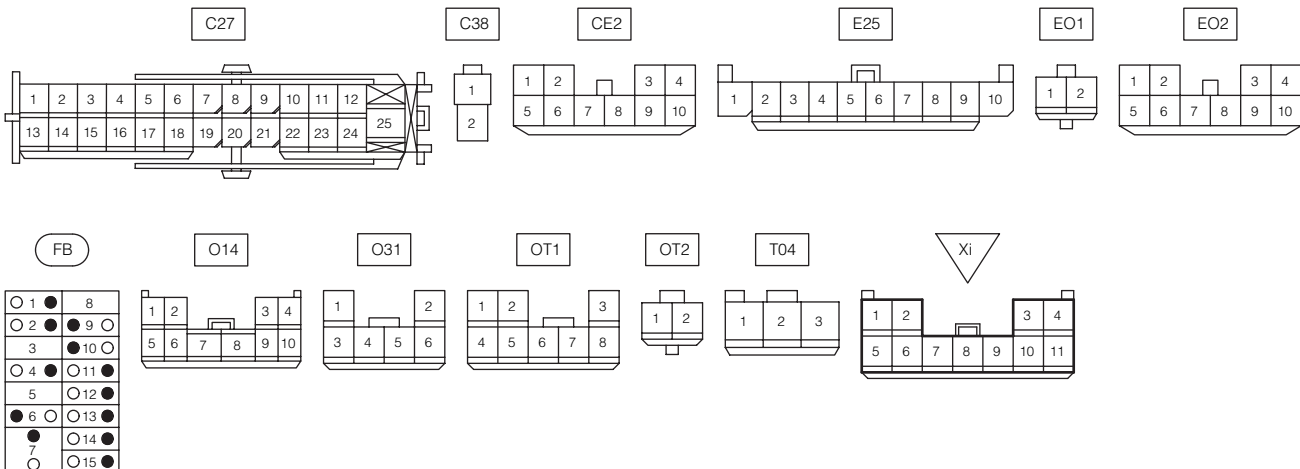
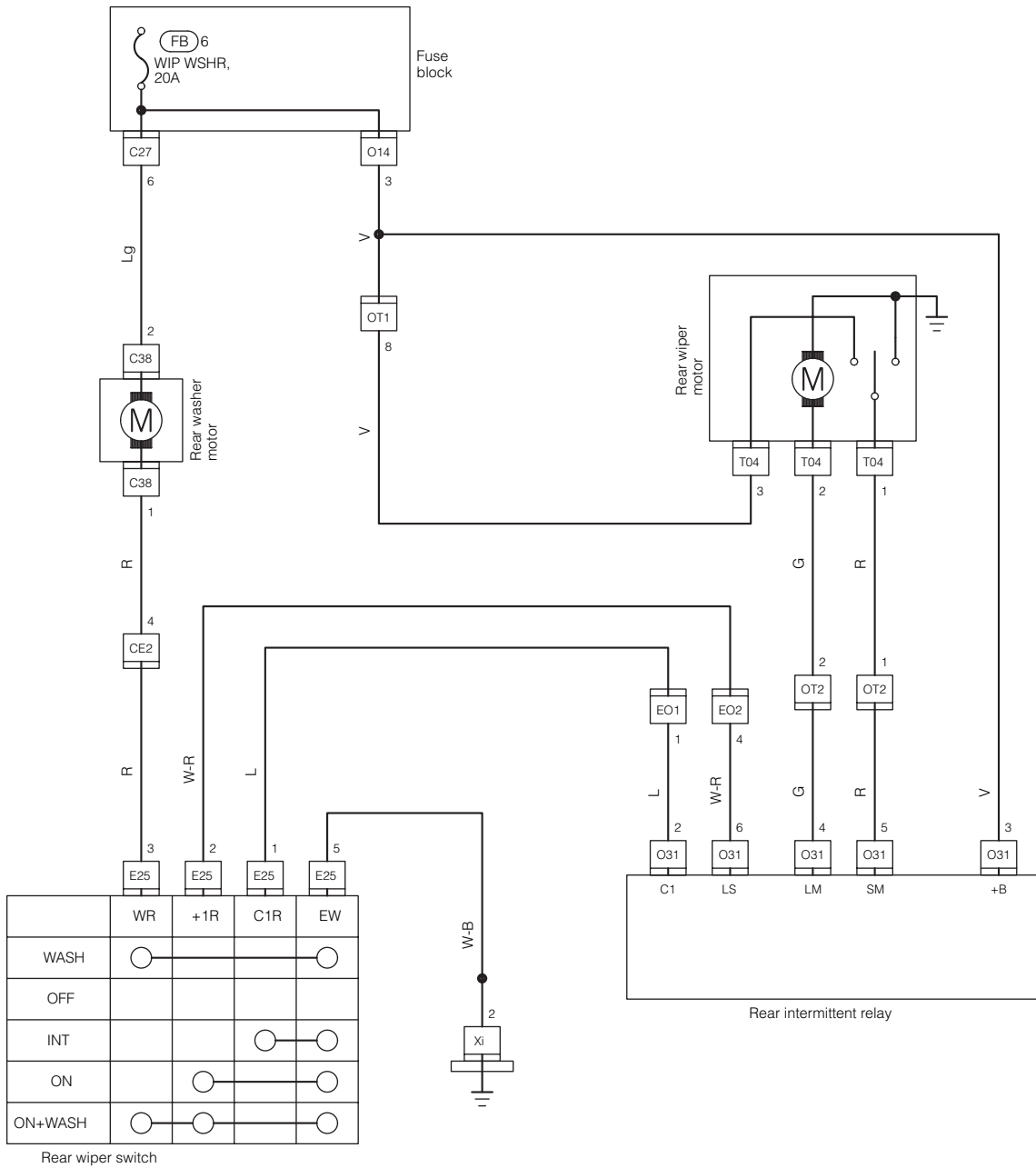

(MEMO)

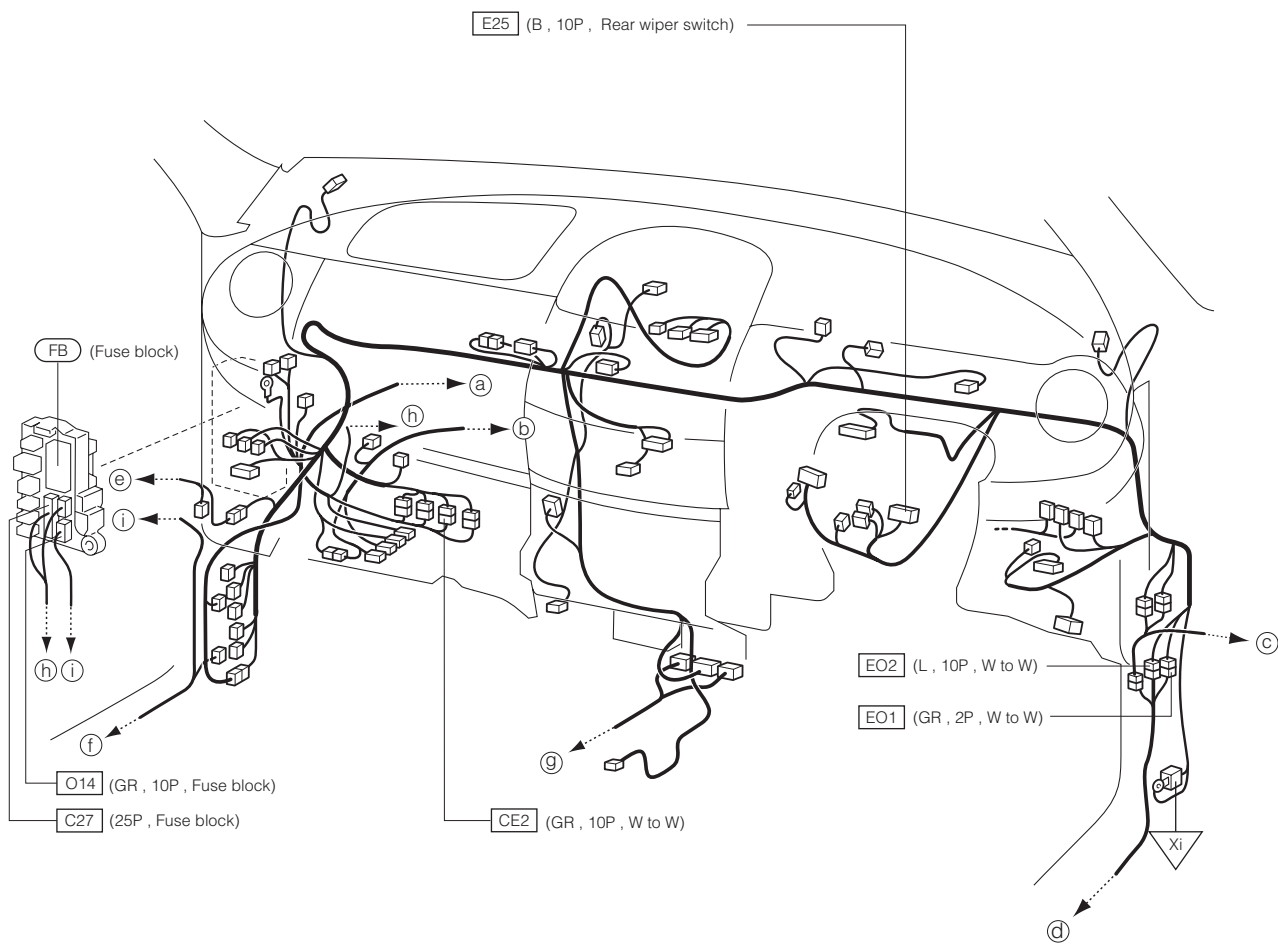

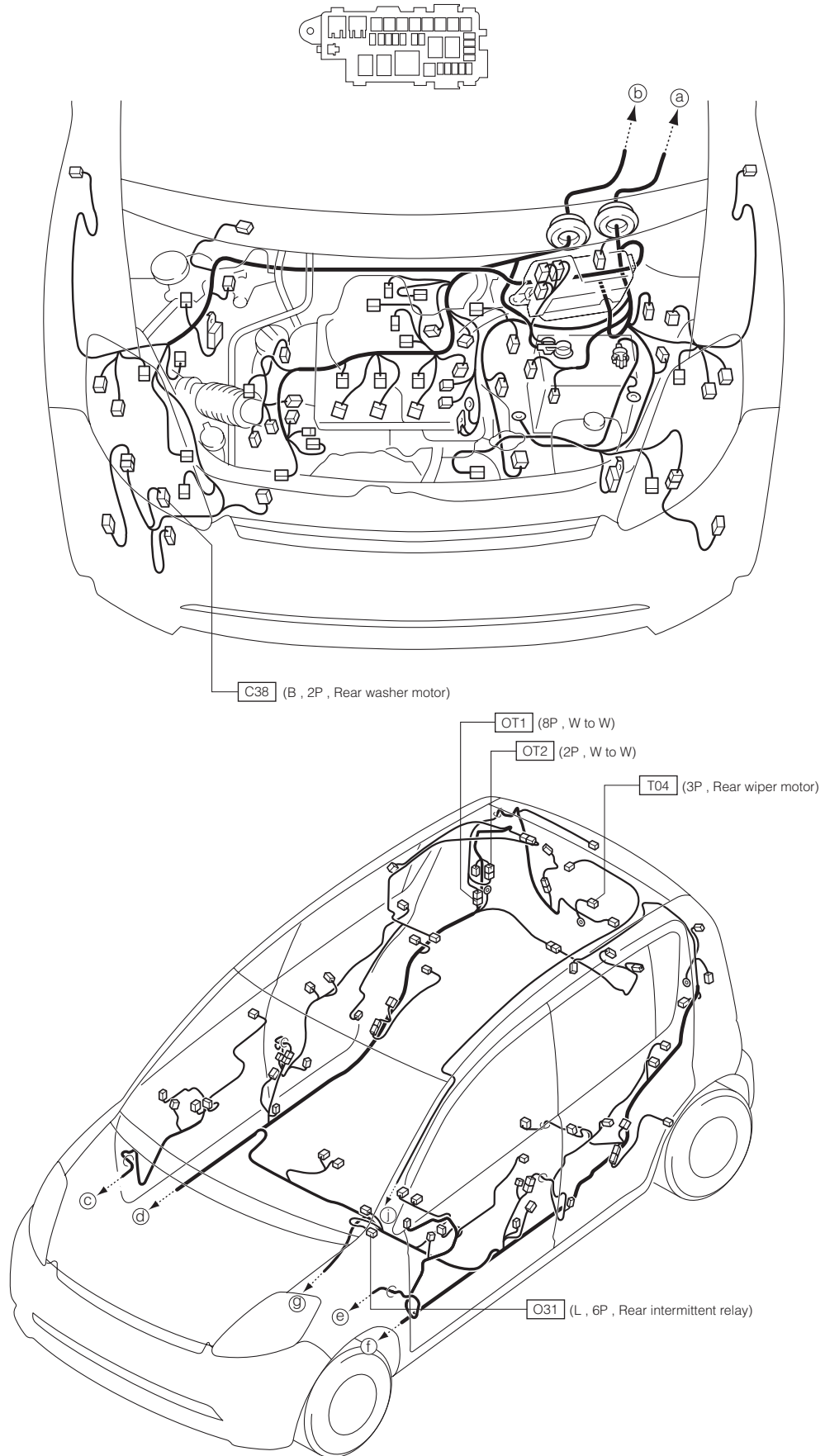

24-2 RHD VEHICLE(WITHOUT INT SYSTEM)

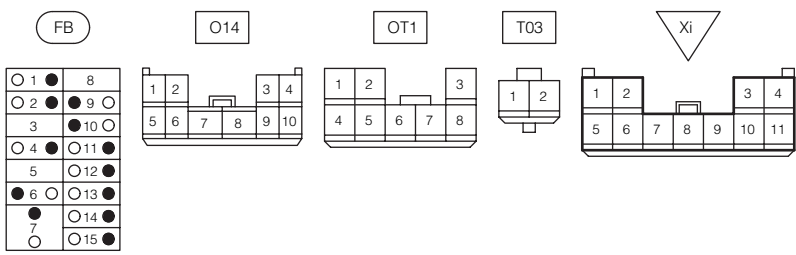
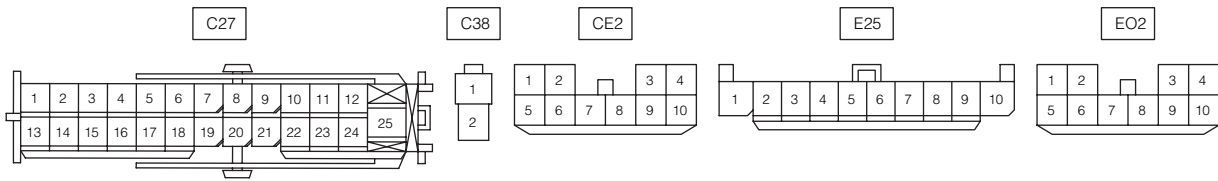
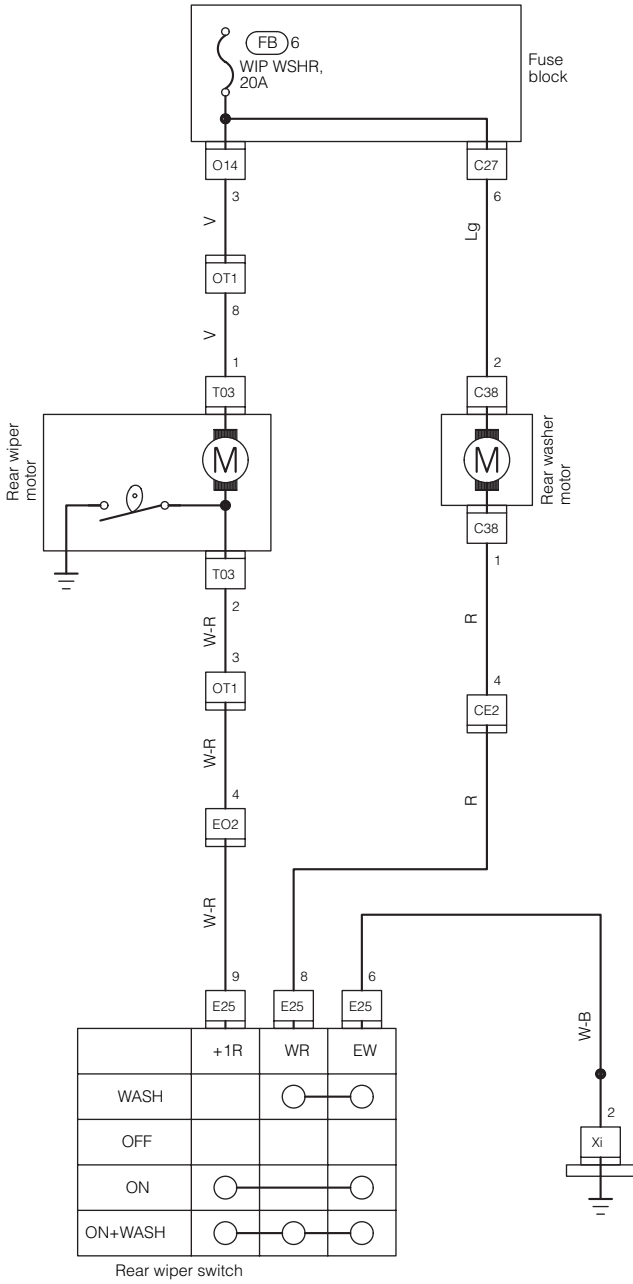

(MEMO)

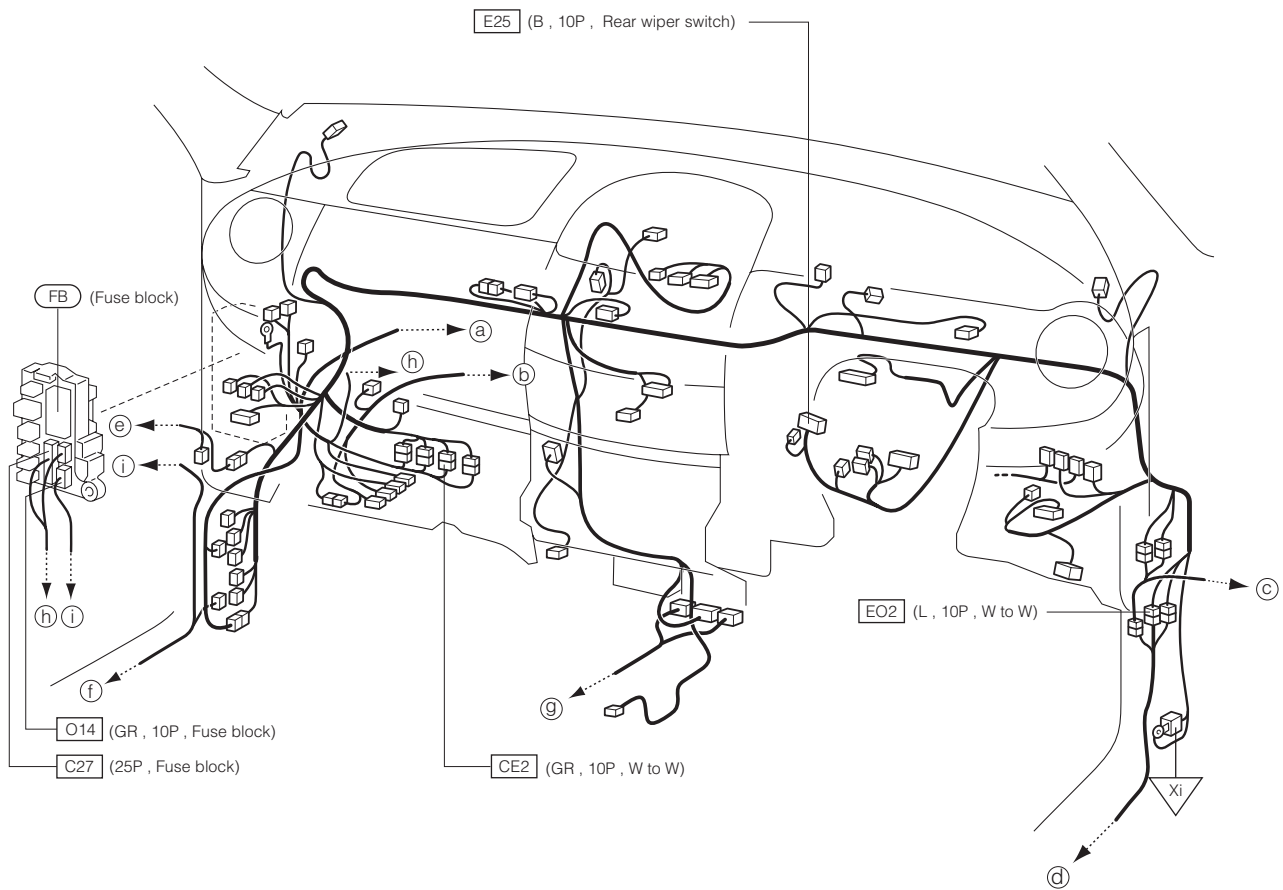

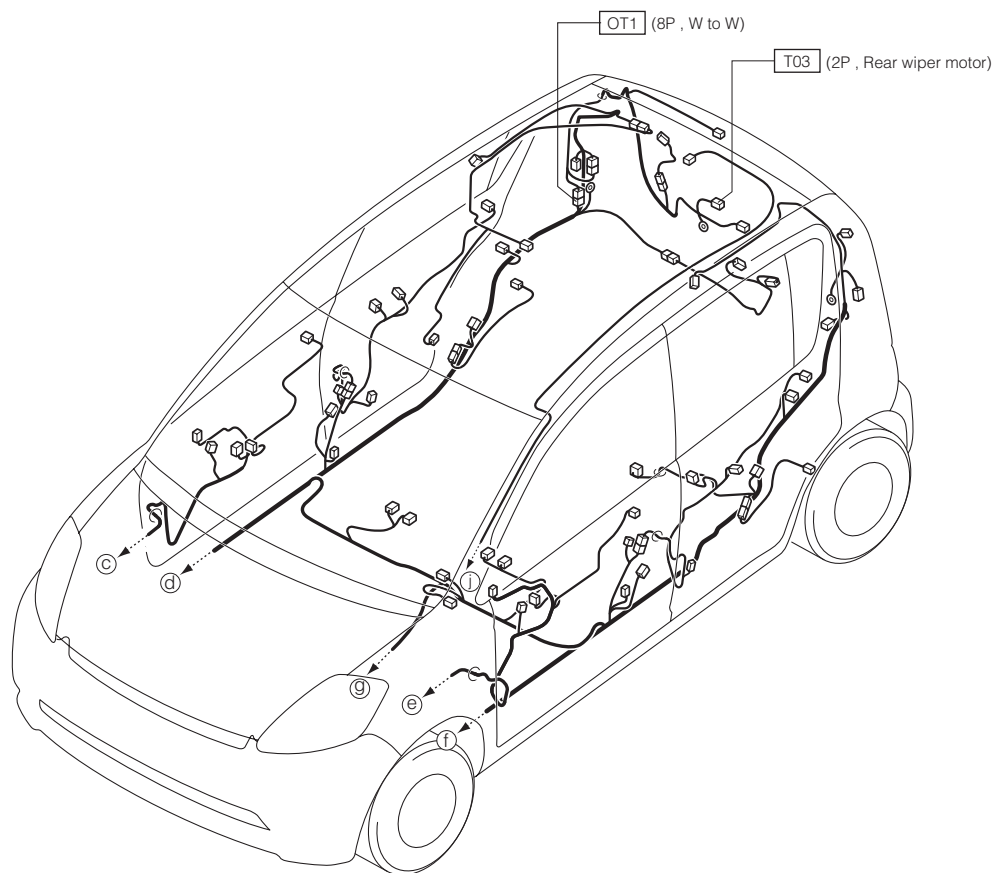
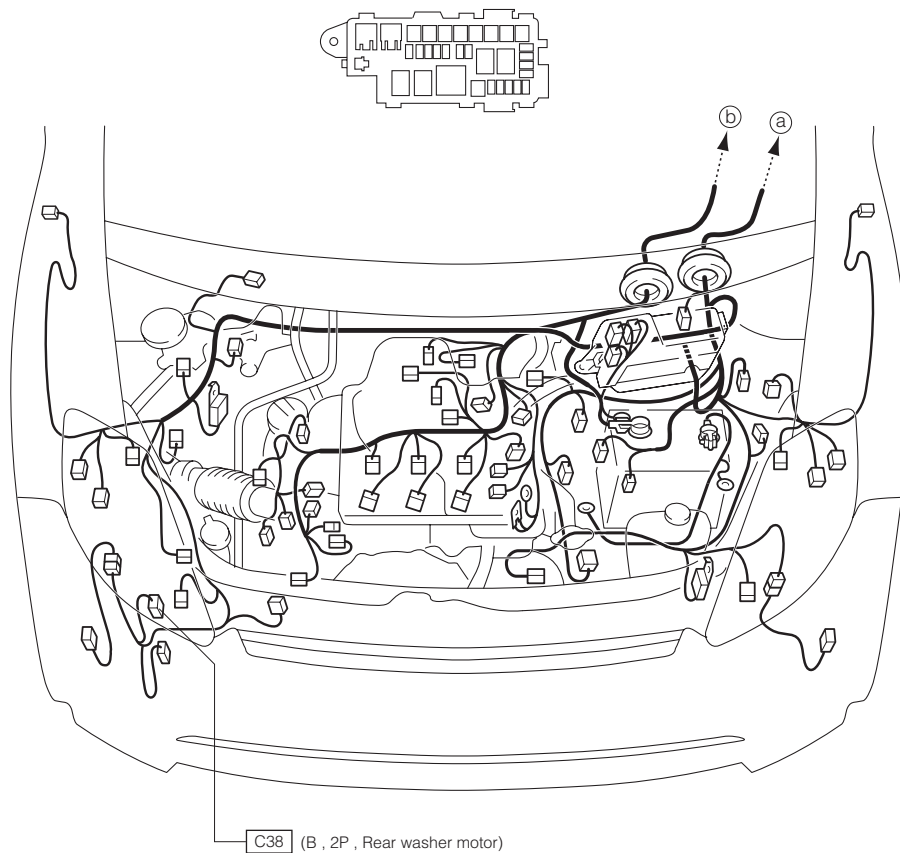

24-3 LHD VEHICLE (WITH INT SYSTEM)

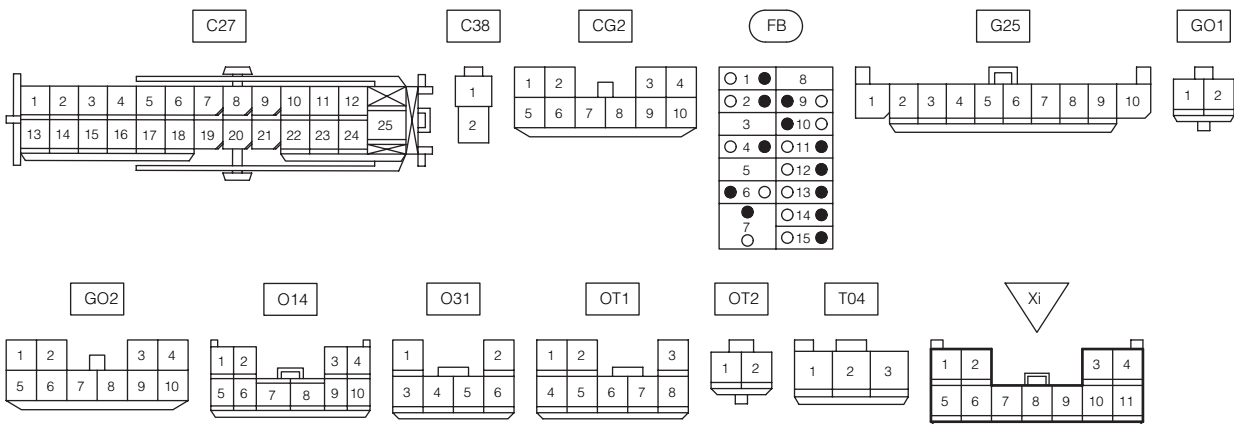
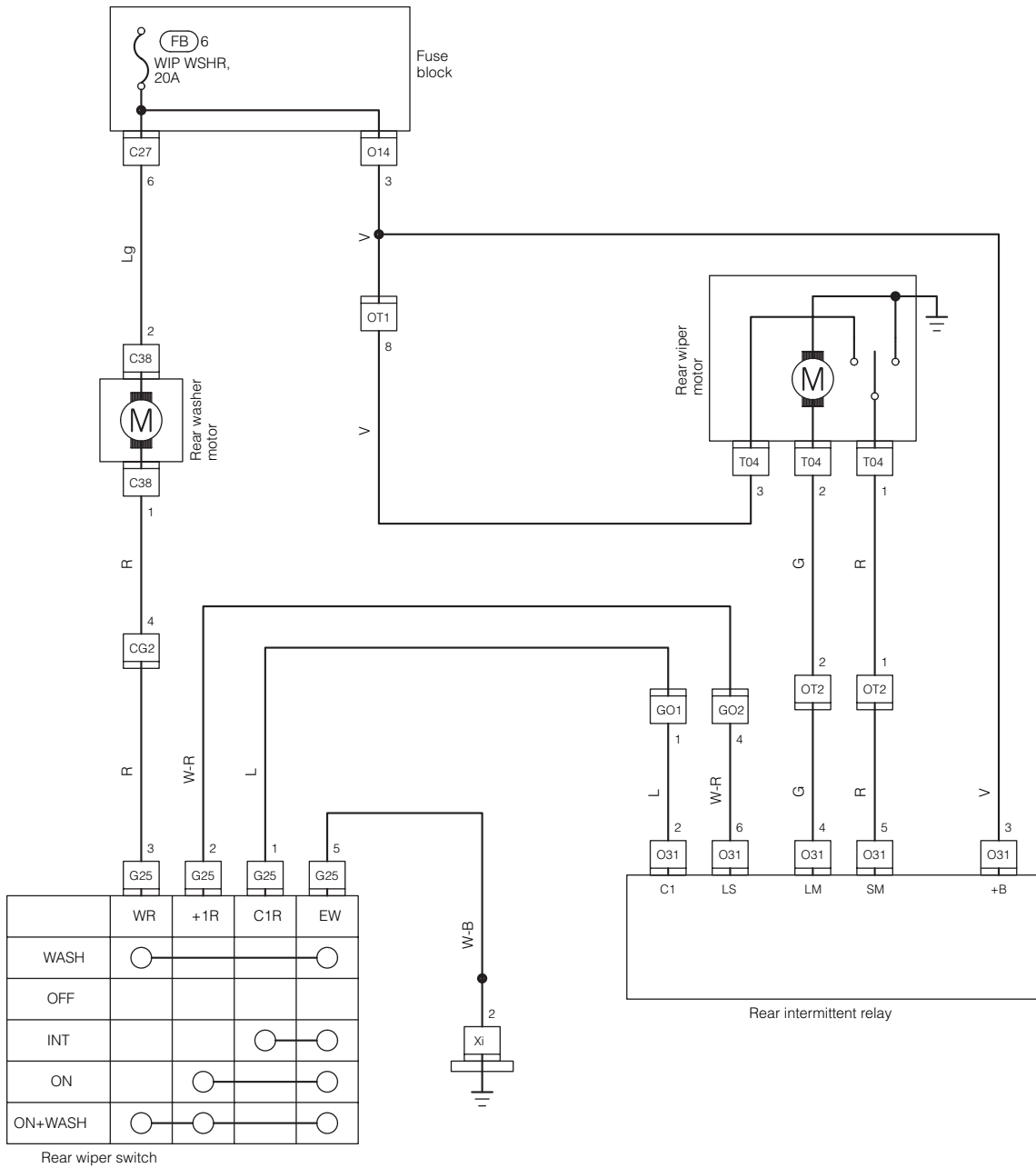

(MEMO)

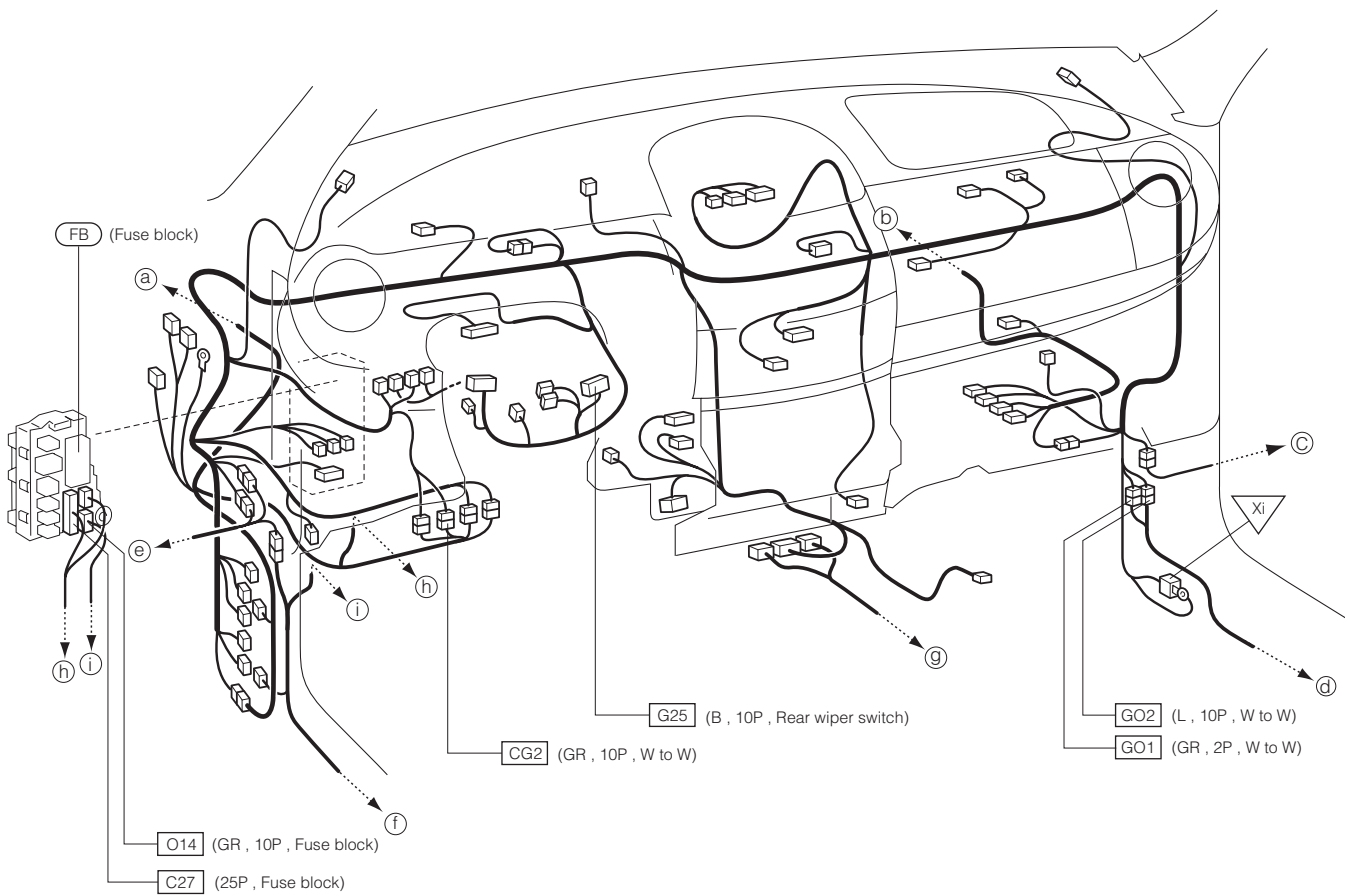

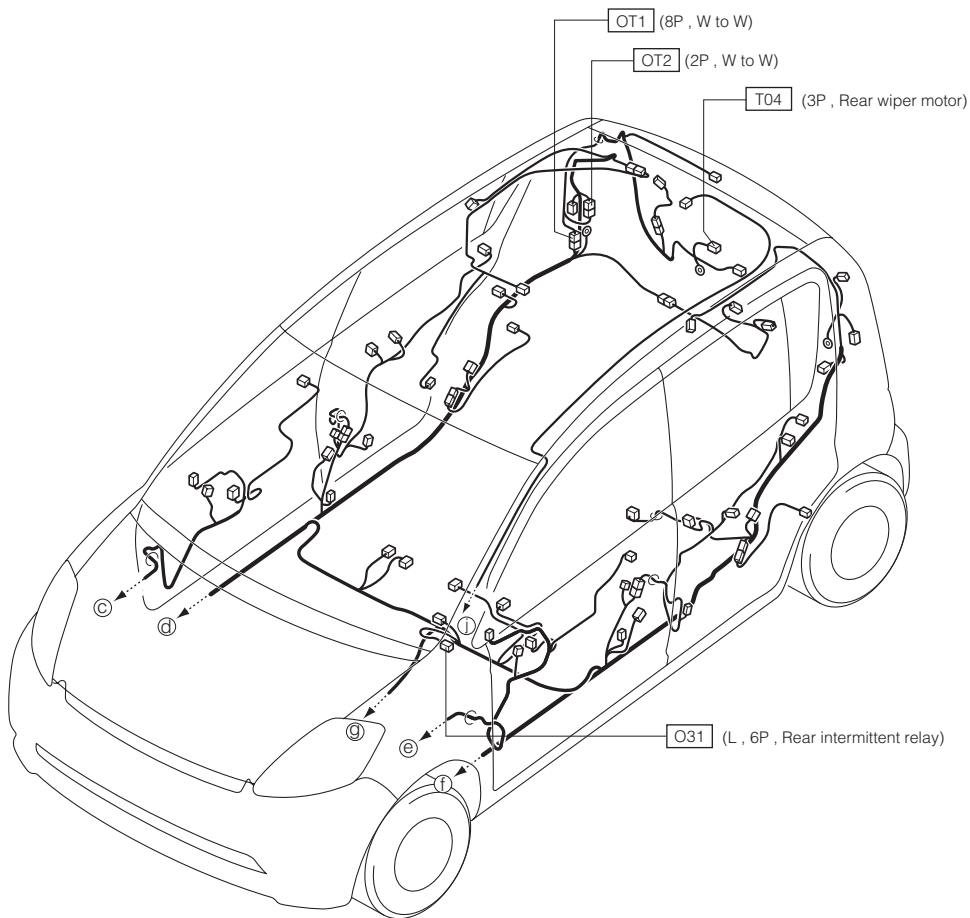
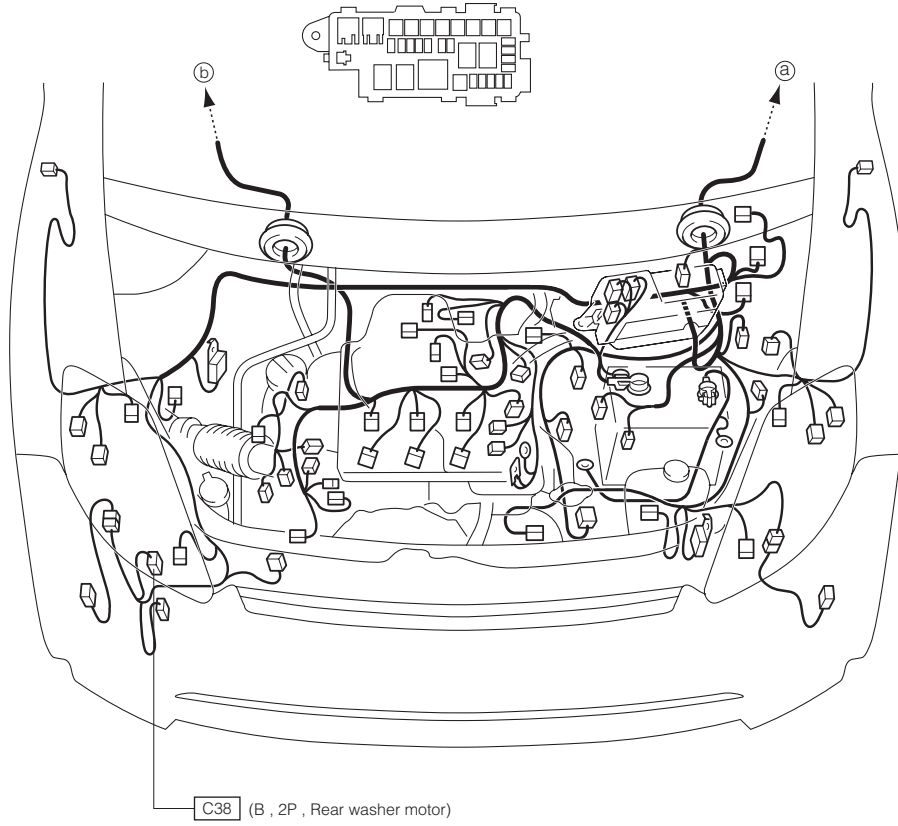

24-4 LHD VEHICLE(WITHOUT INT SYSTEM)

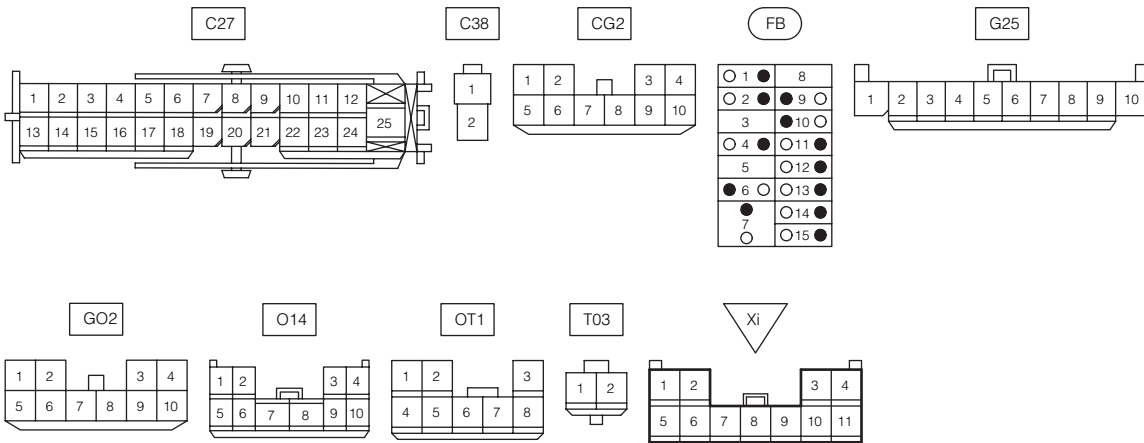
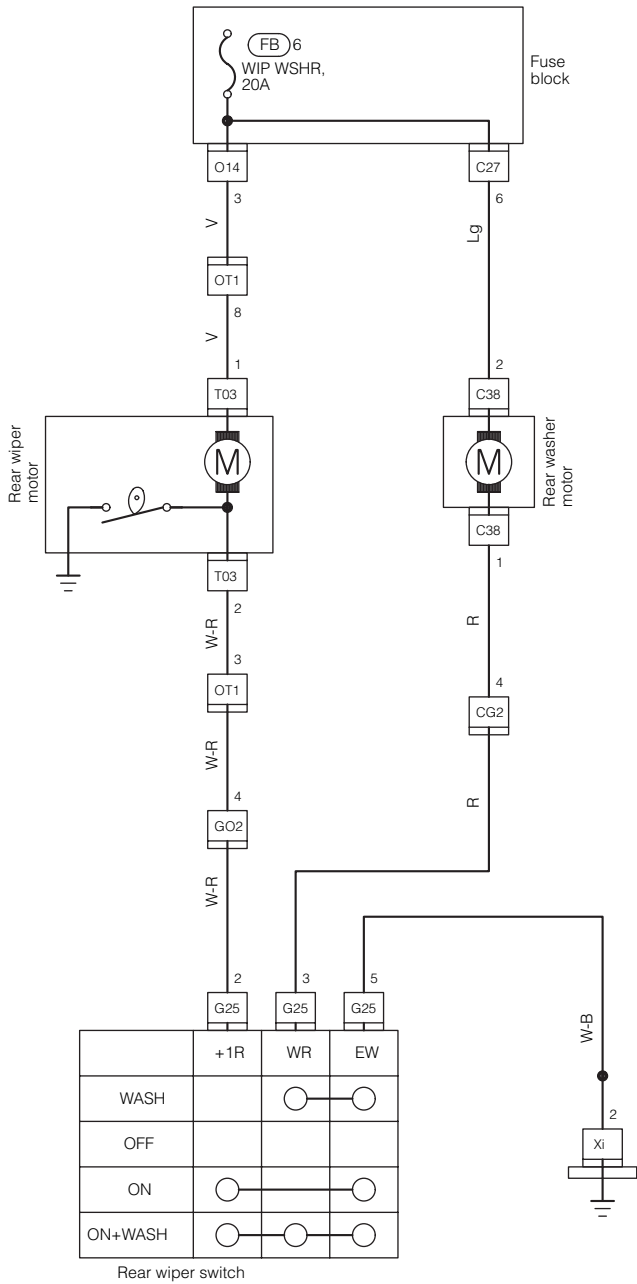

(MEMO)

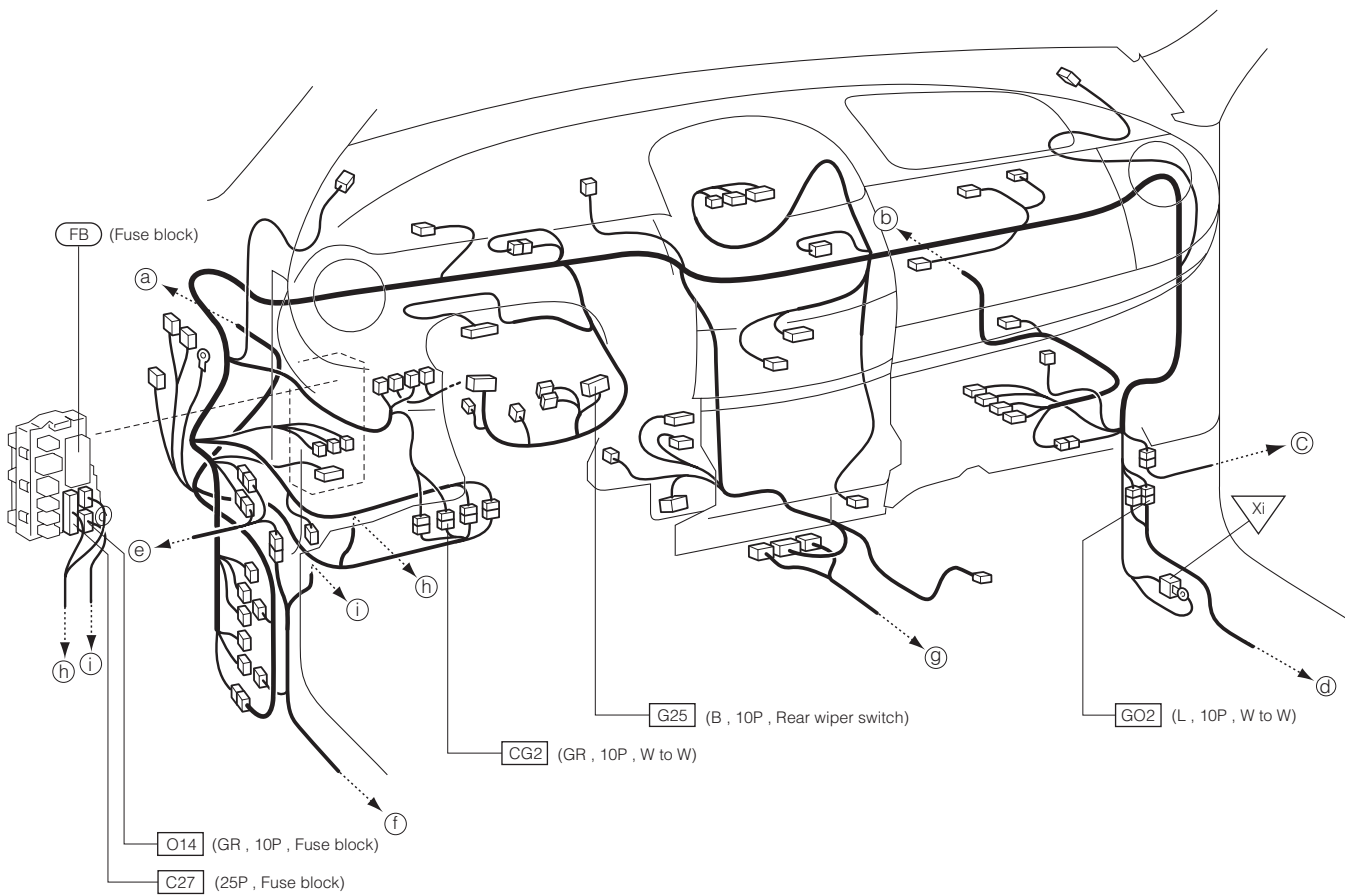

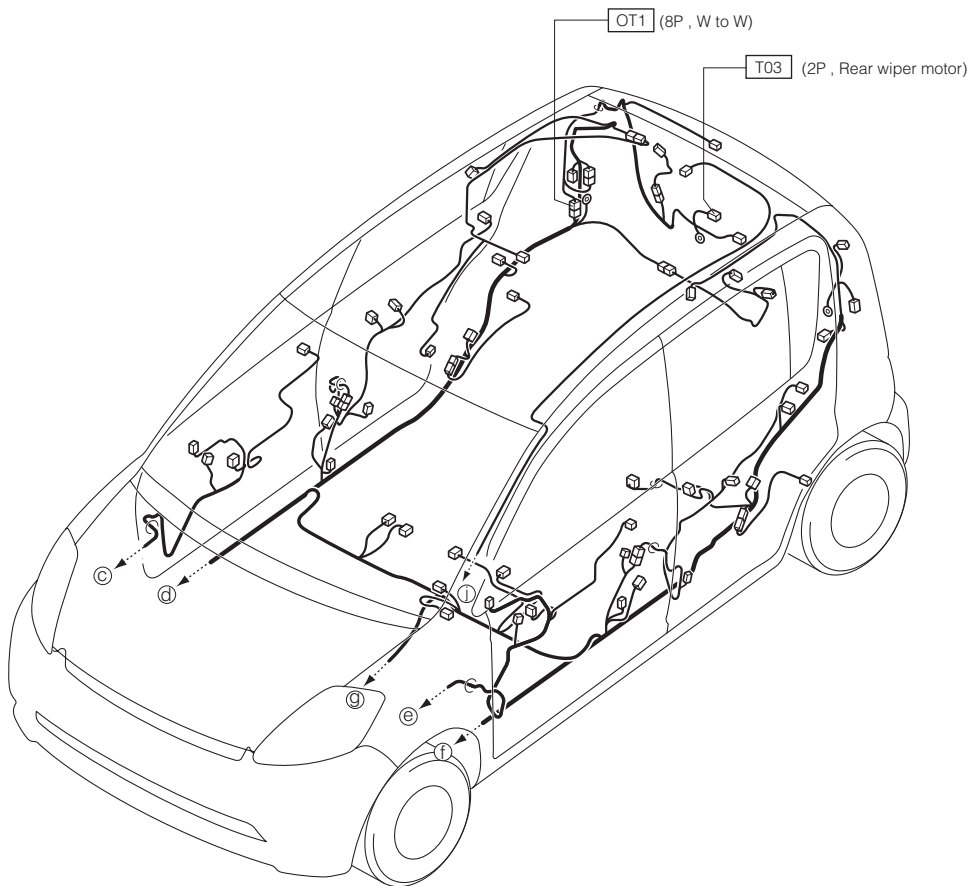
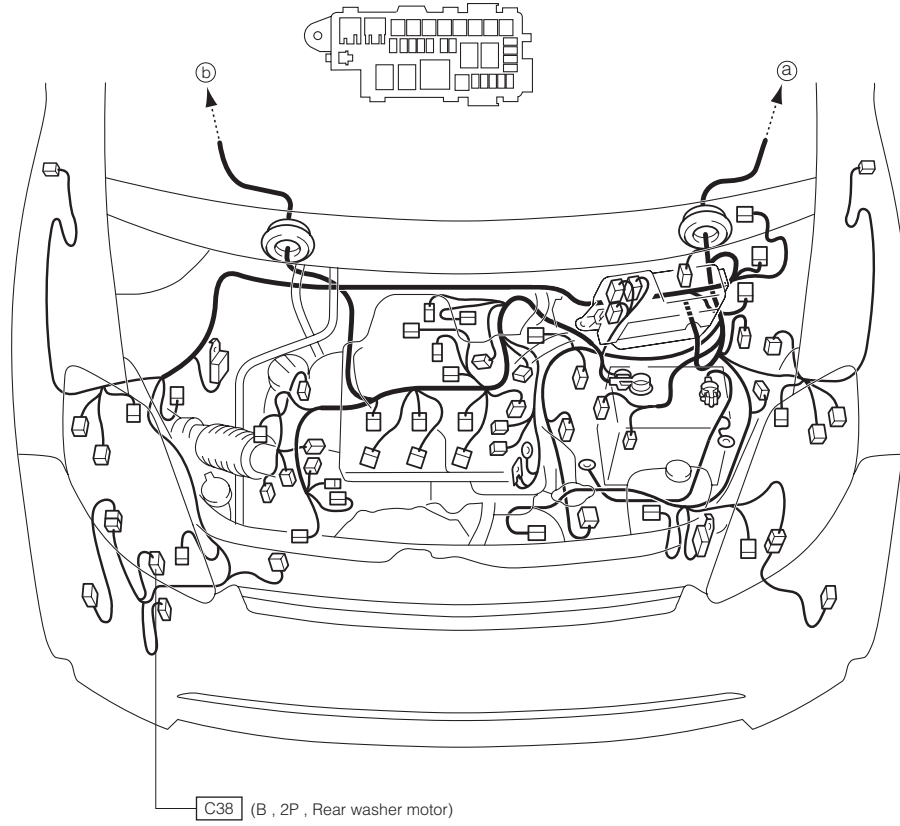

D-221

25 RADIO 25-1 RHD VEHICLE

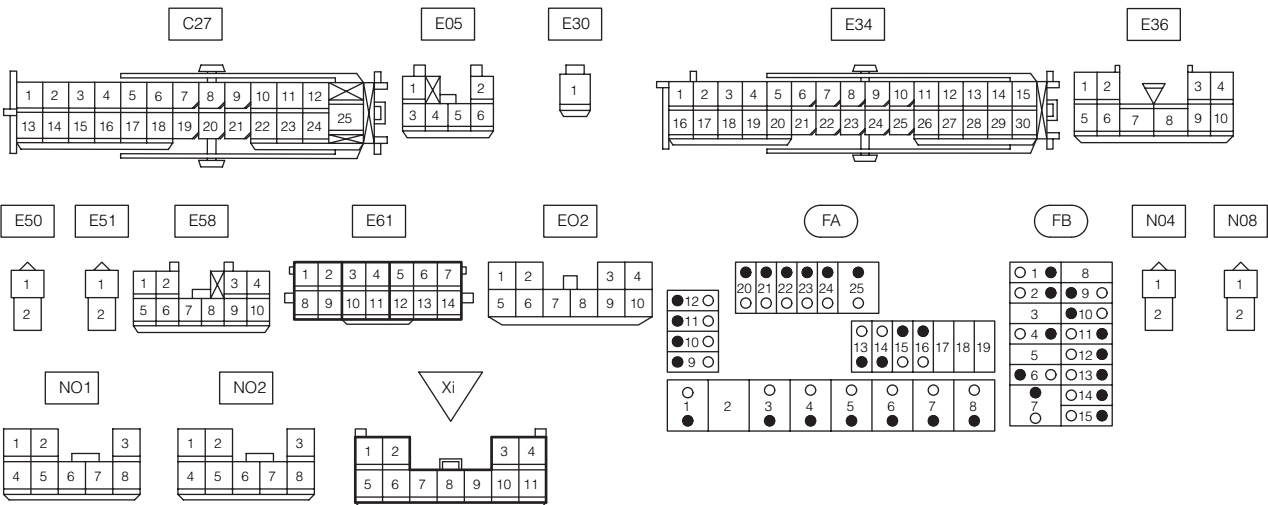
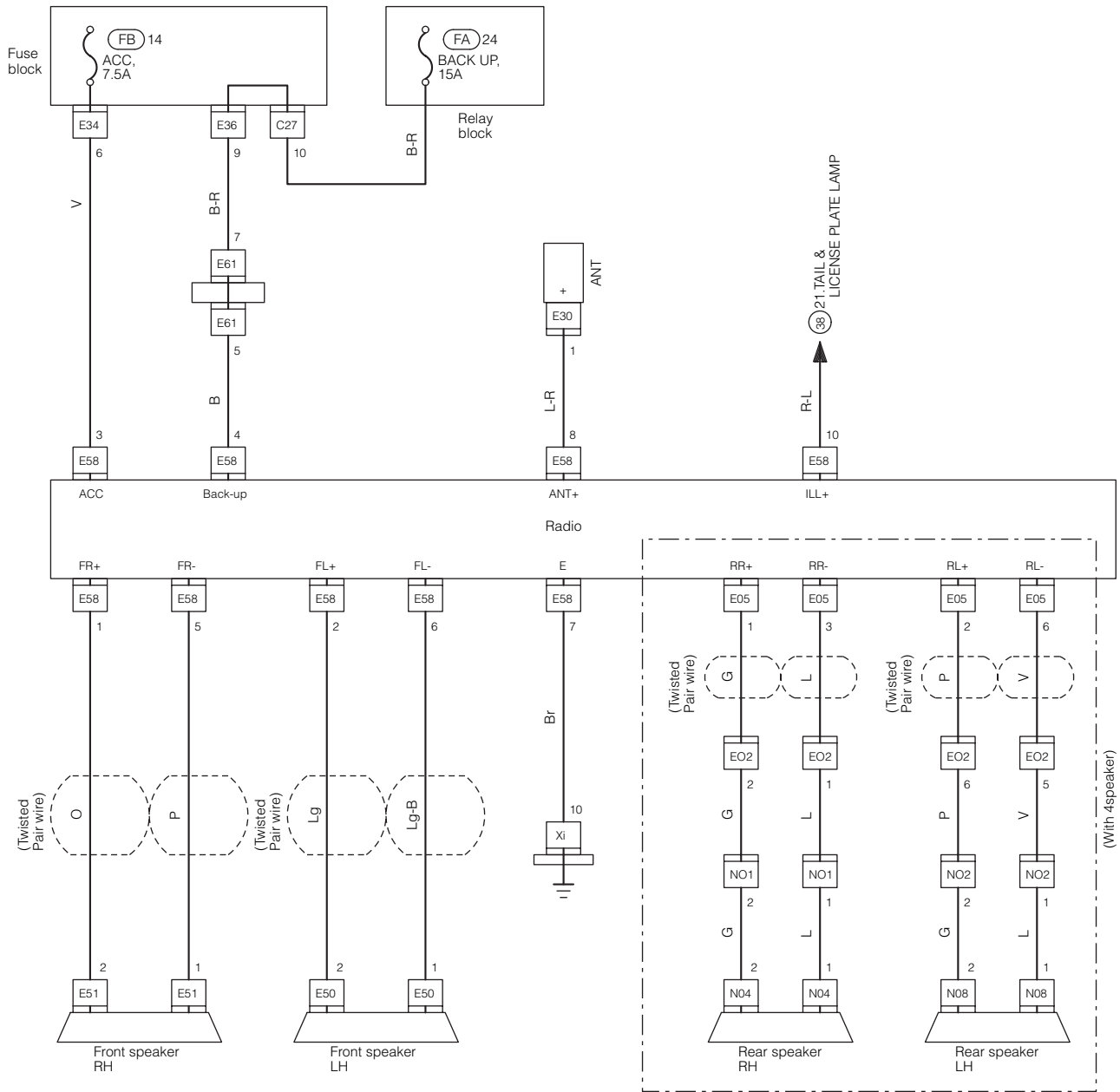

(MEMO)

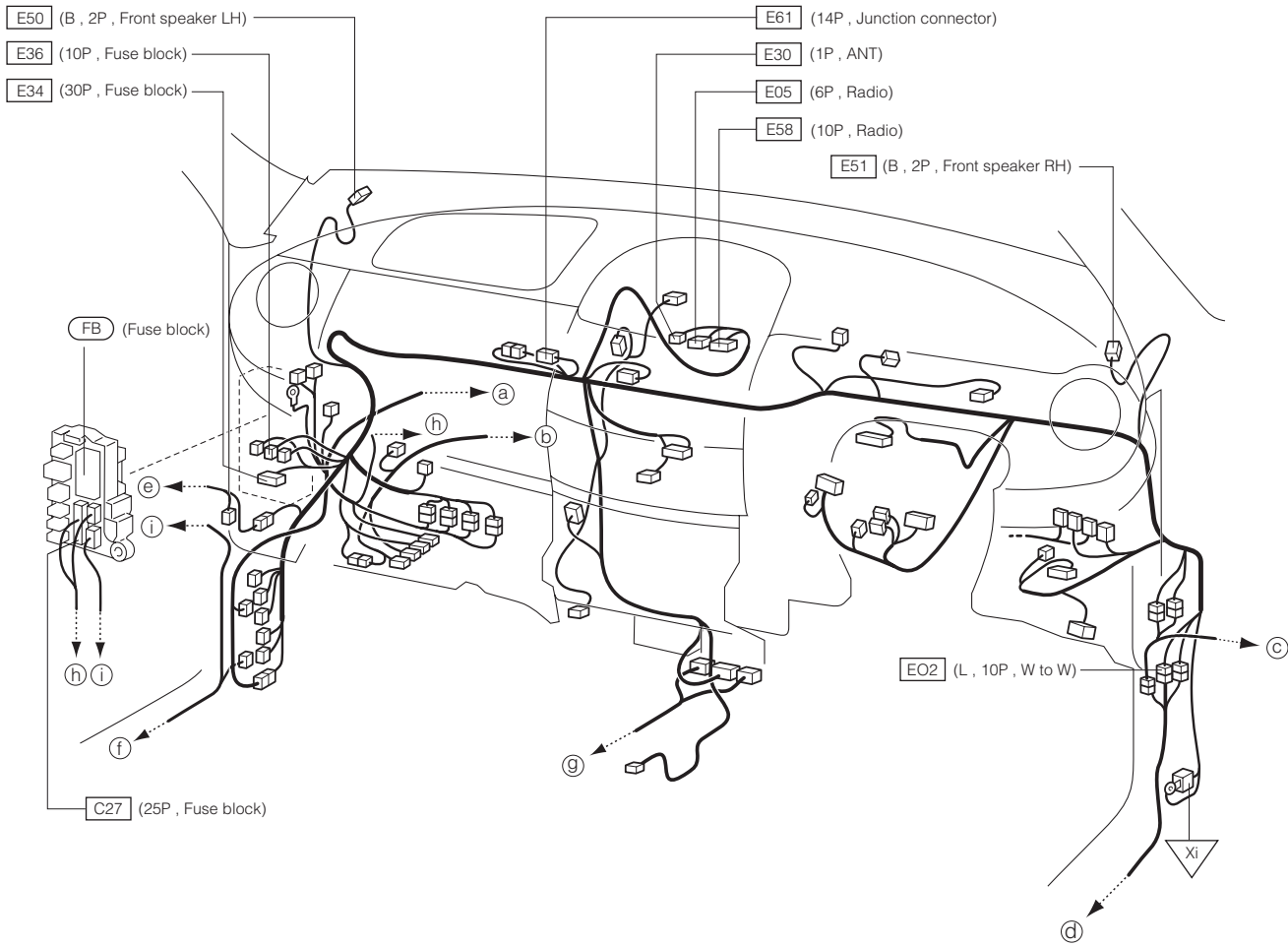

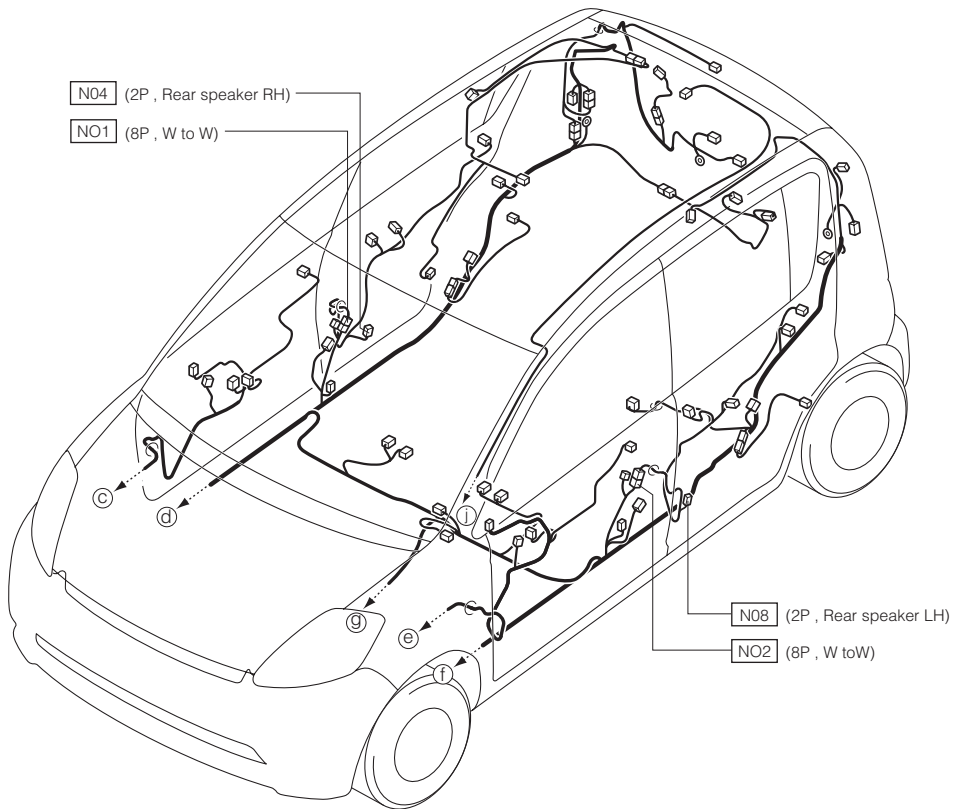
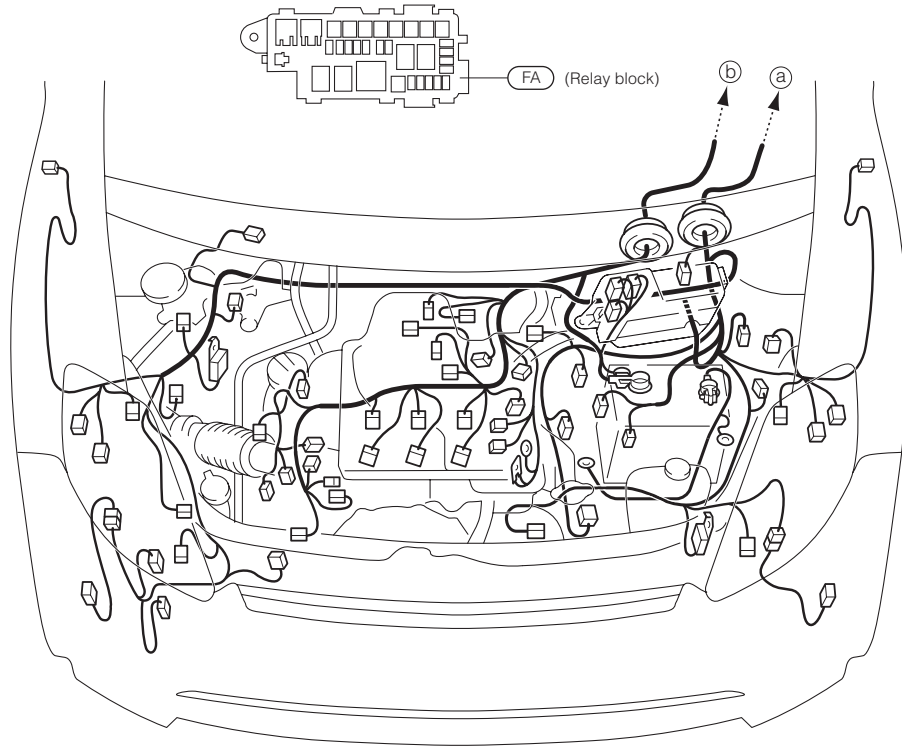

25-2 LHD VEHICLE

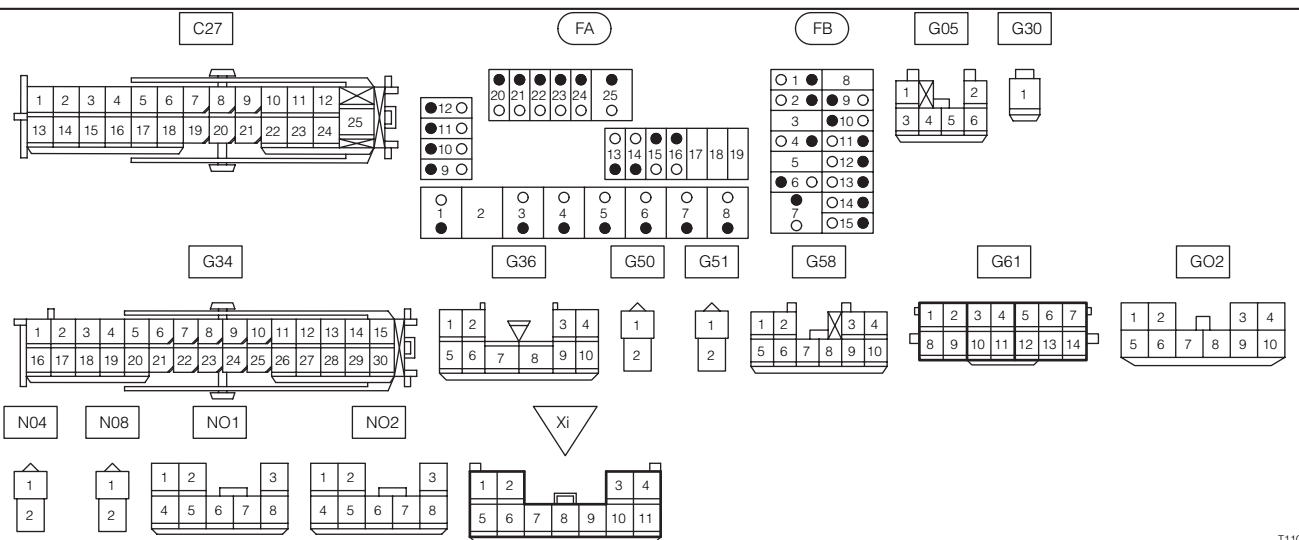
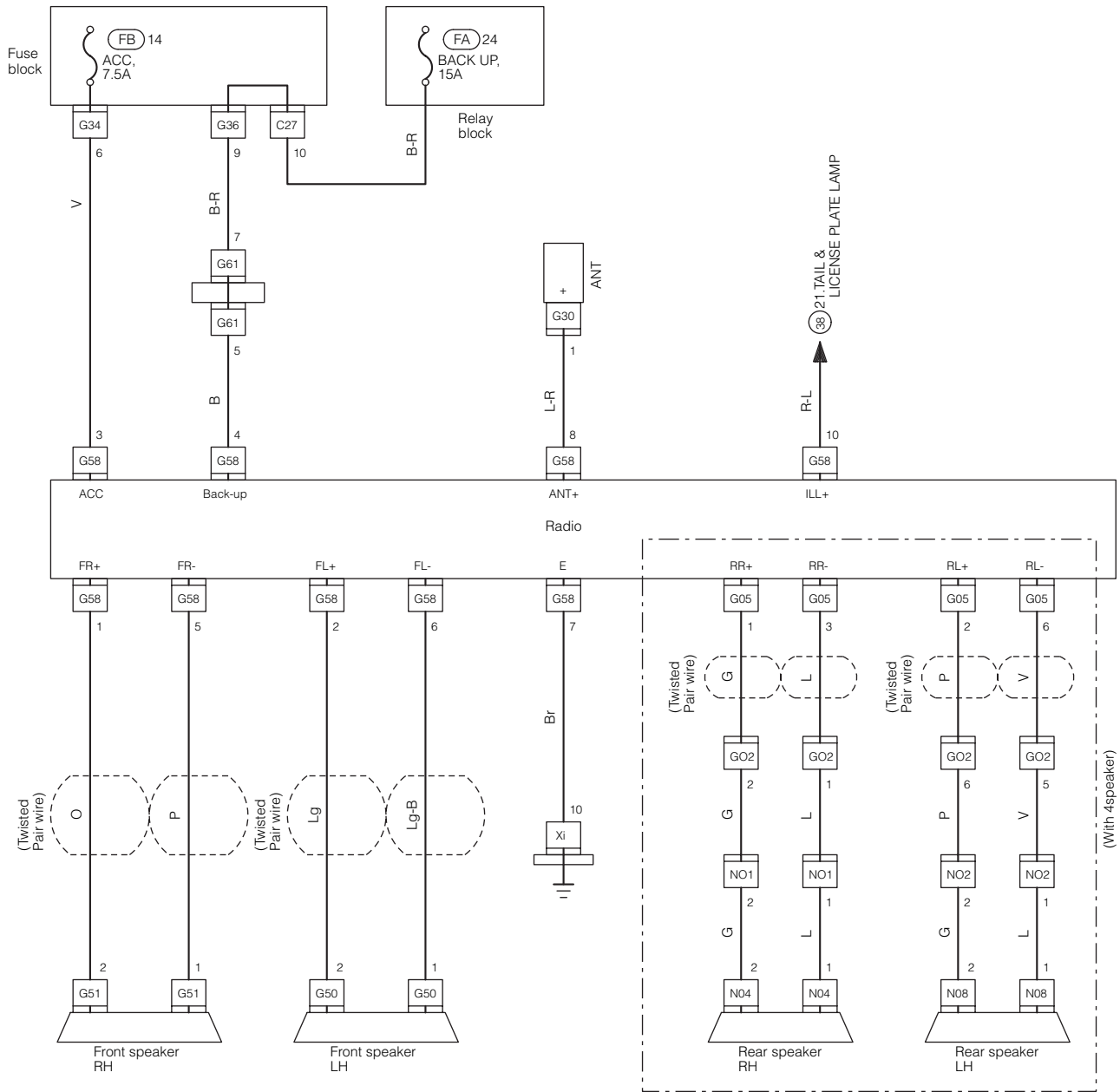

(MEMO)

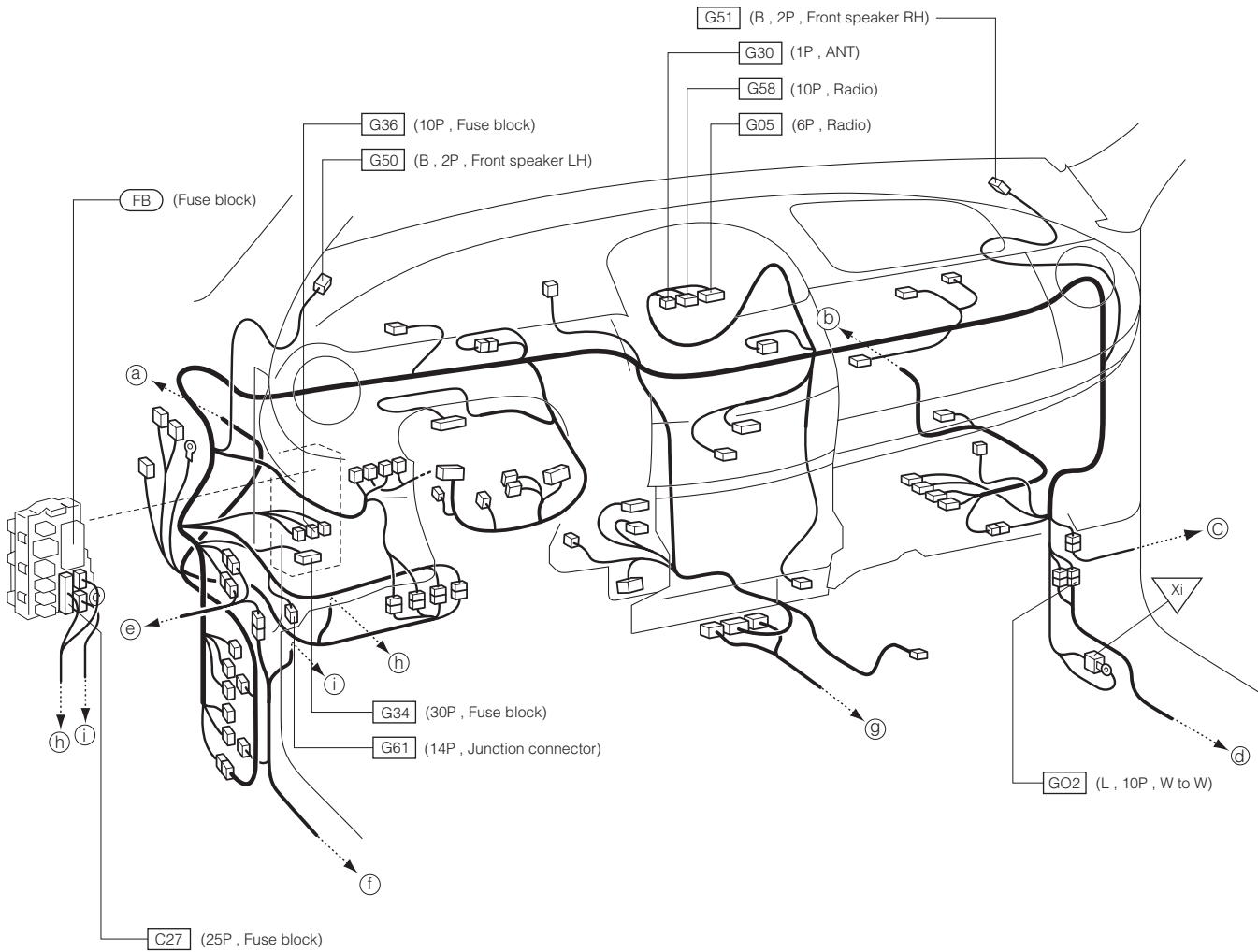

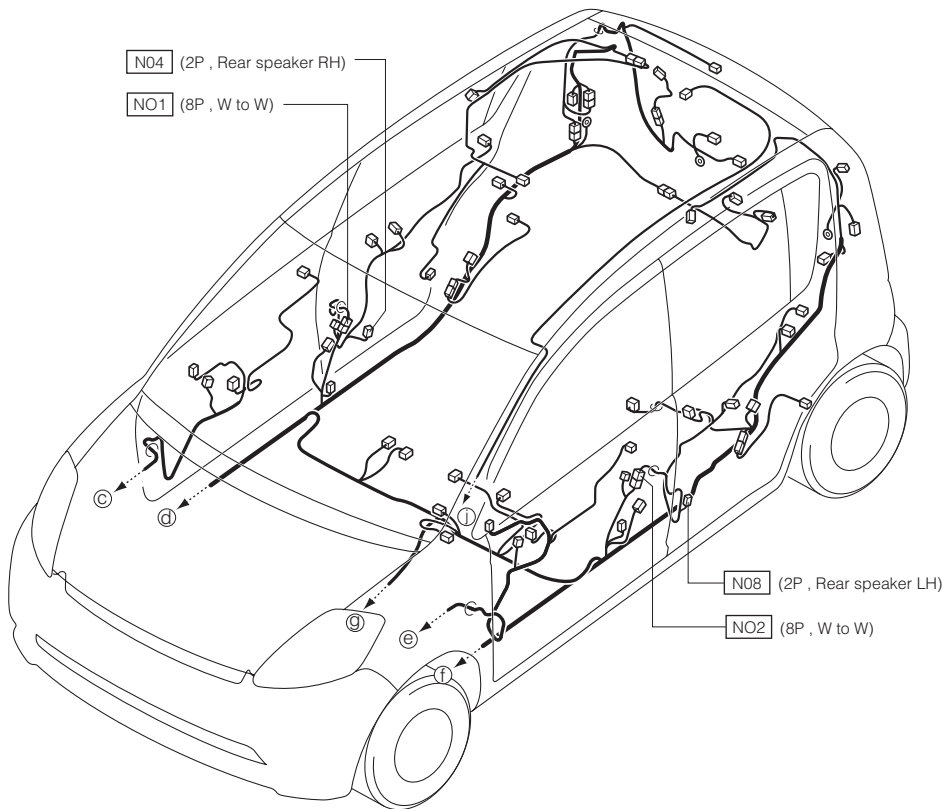
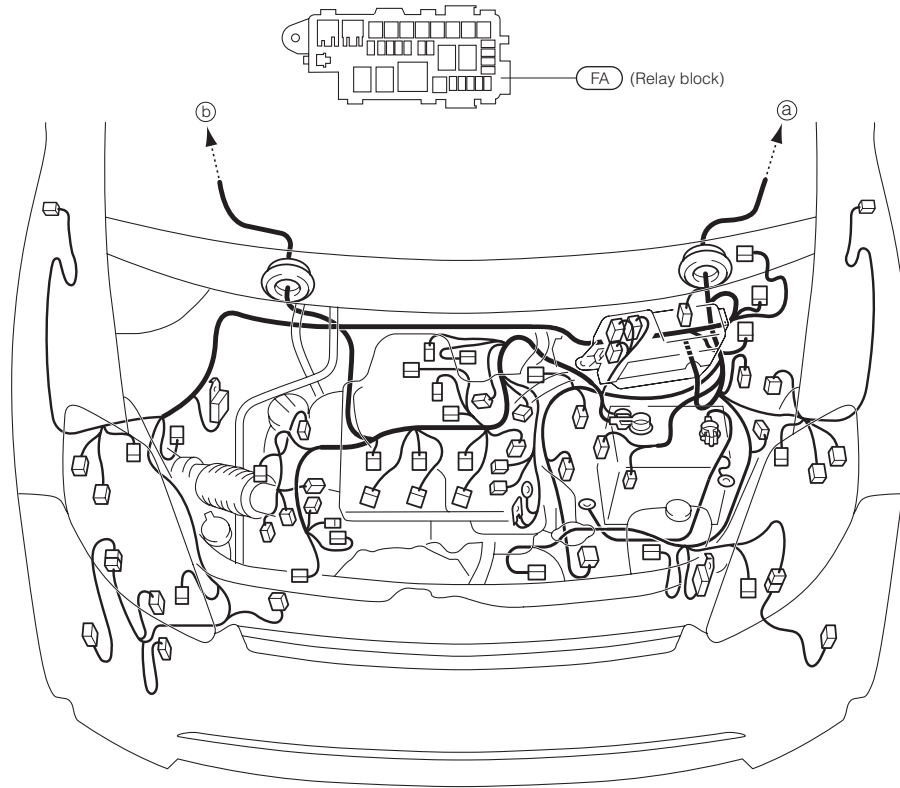

D-229

26 HORN 26-1 RHD VEHICLE

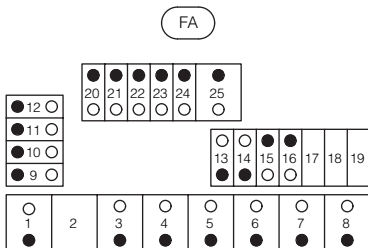
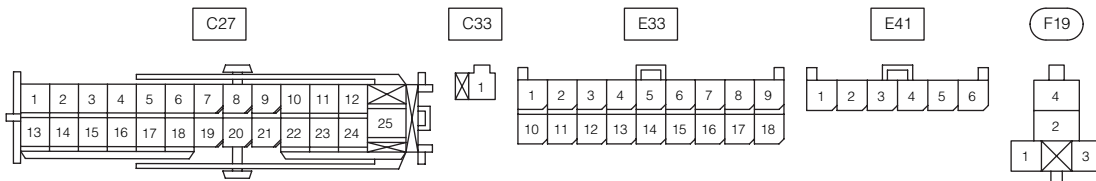
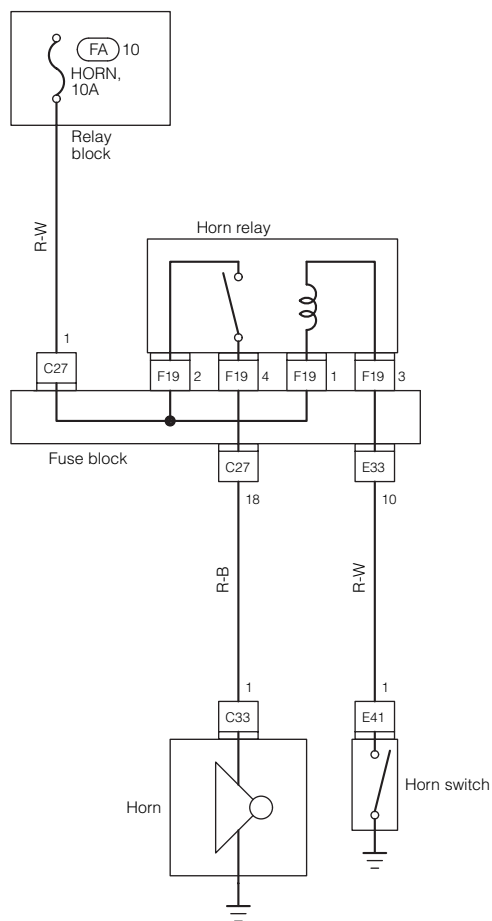

(MEMO)

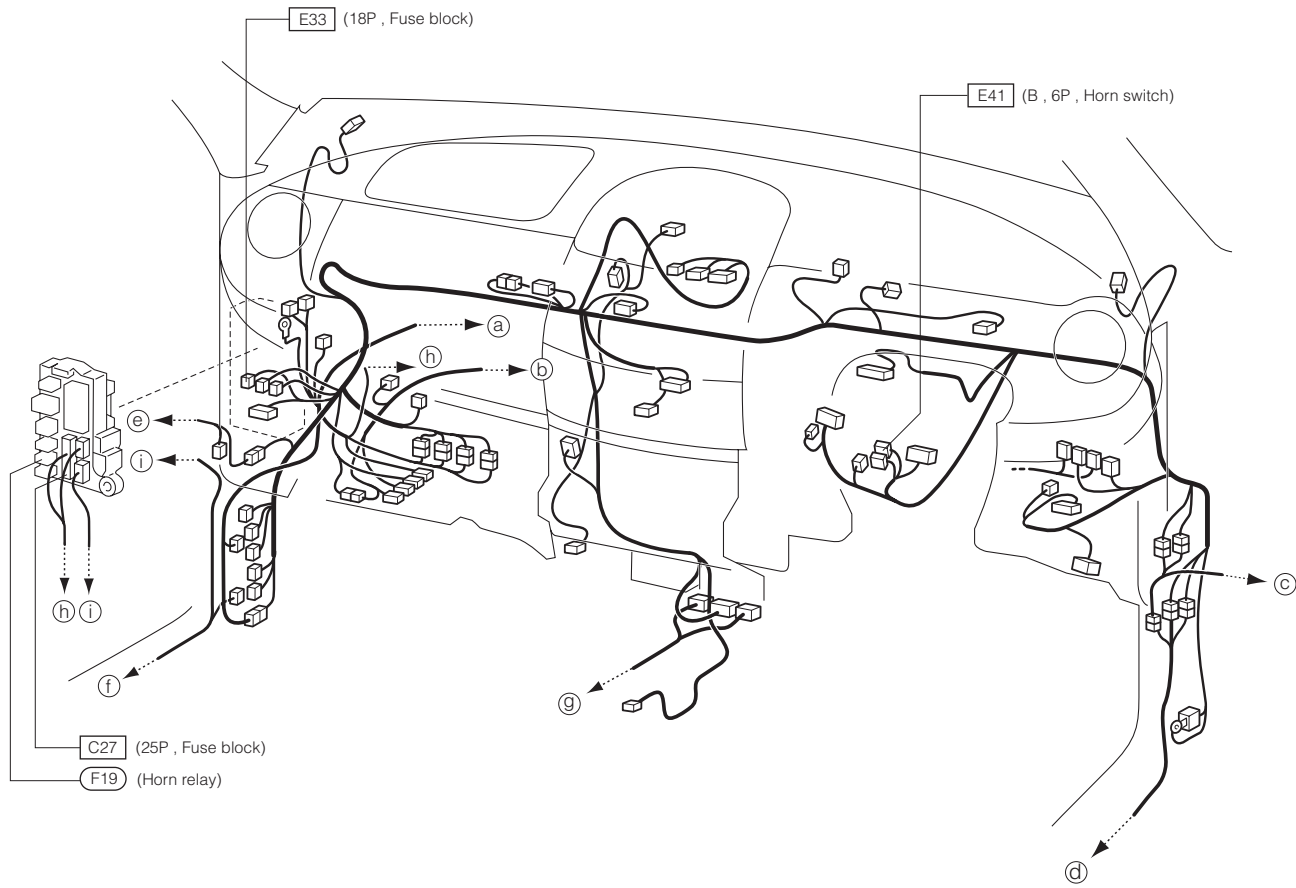

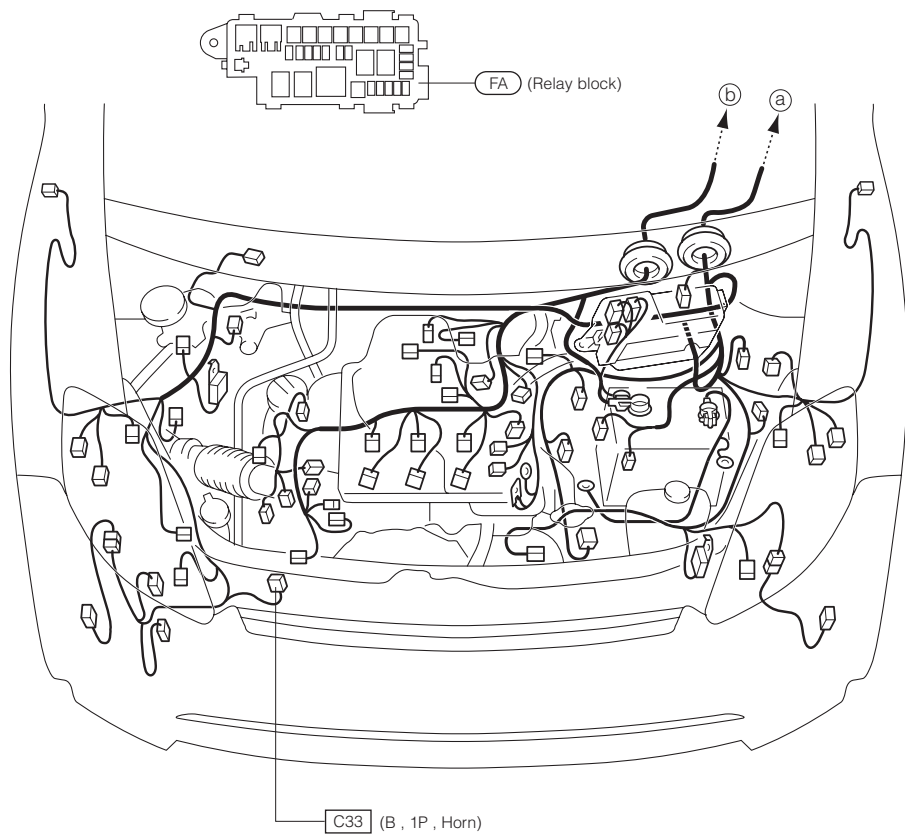

26-2 LHD VEHICLE

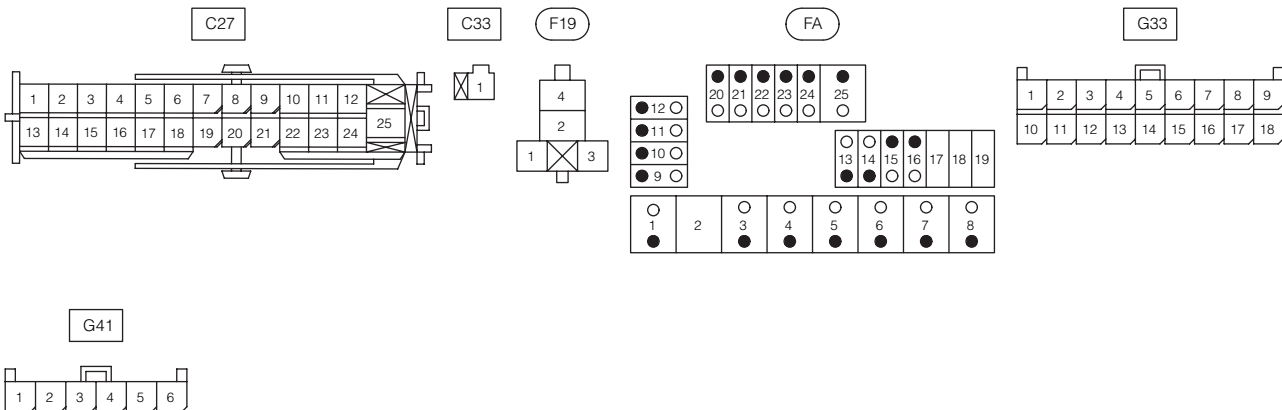
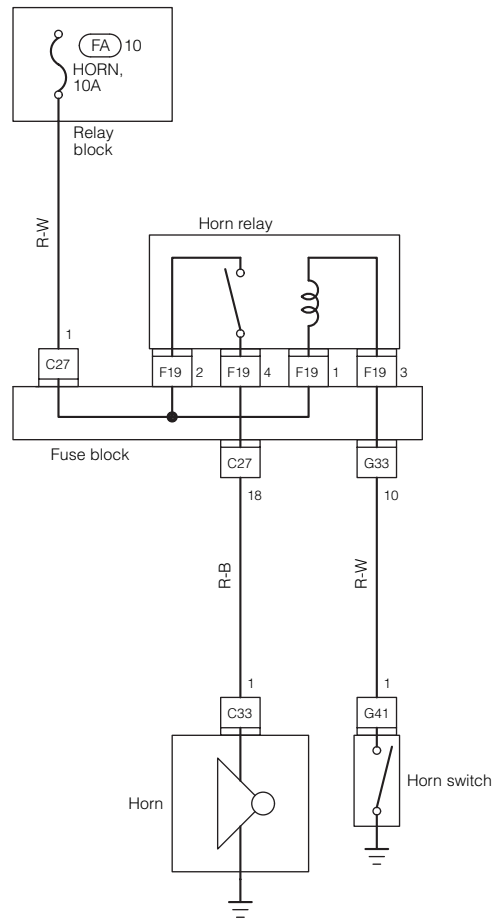

(MEMO)

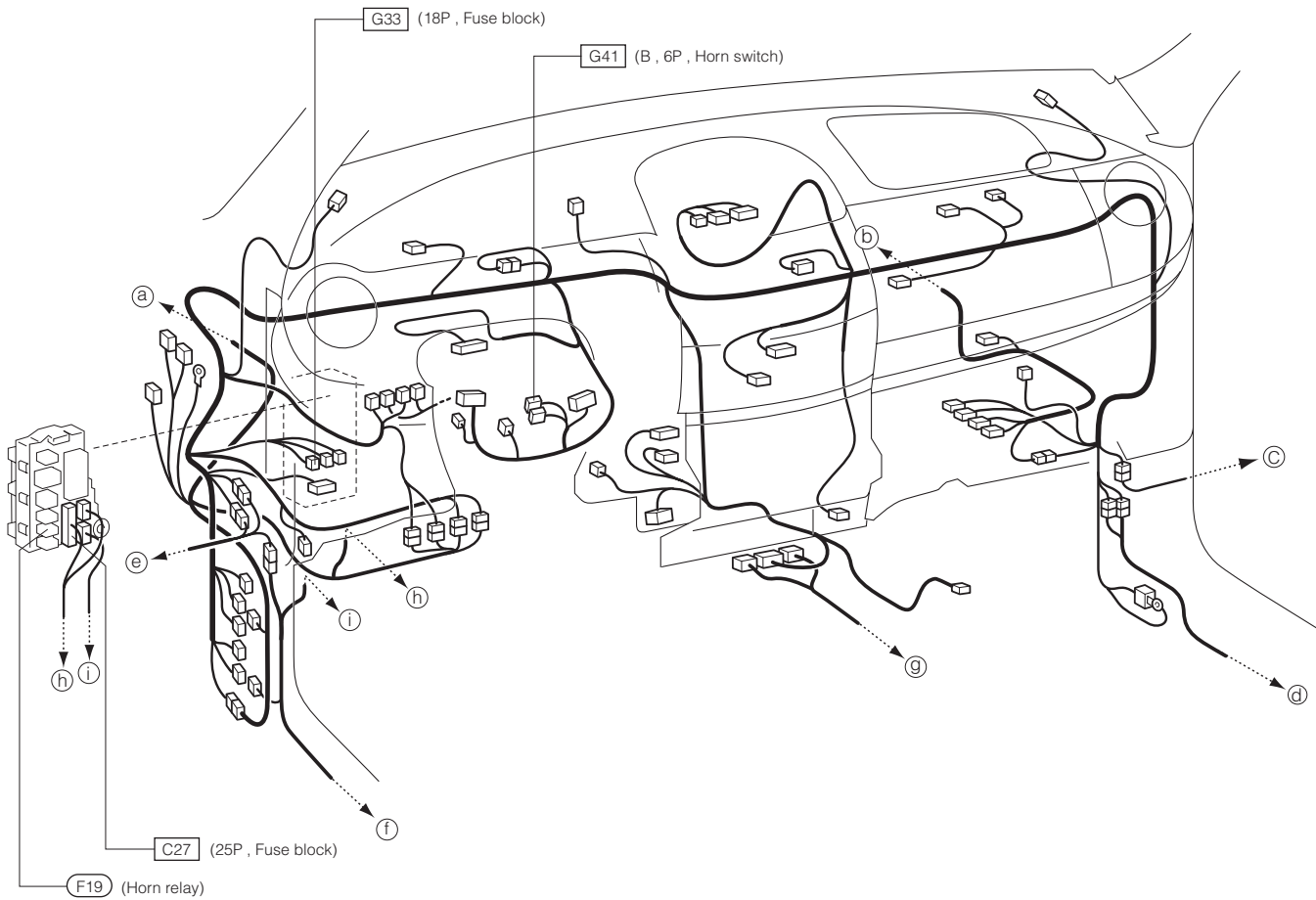

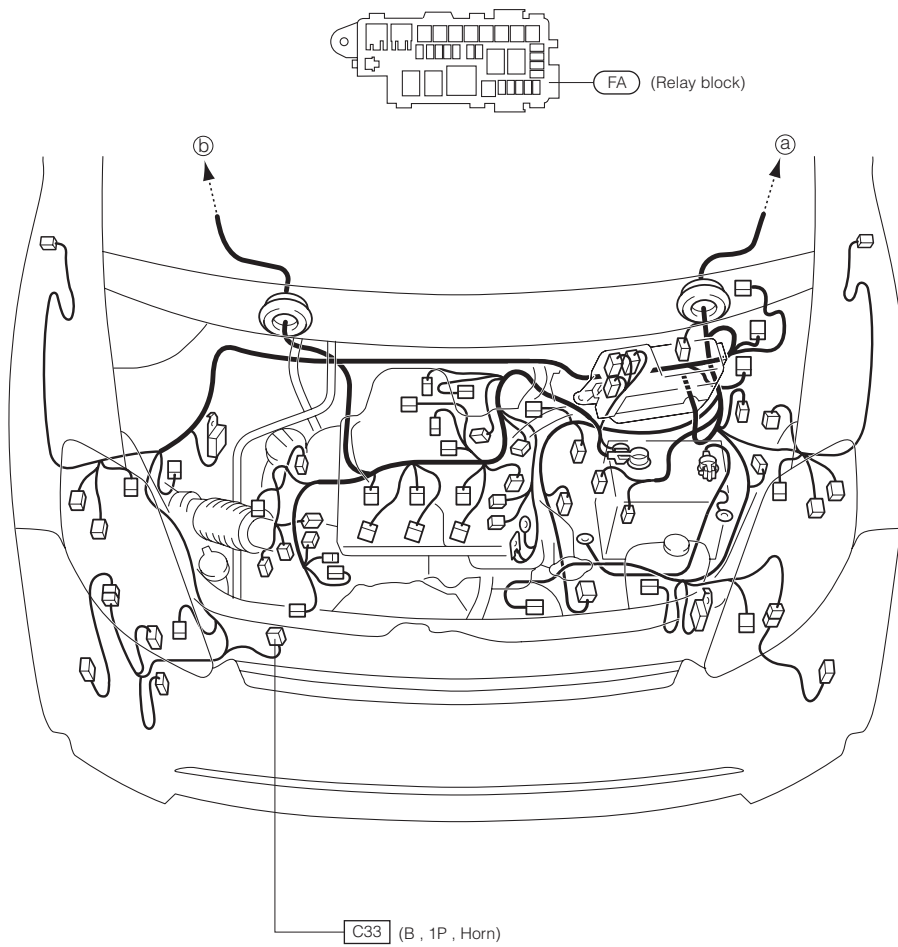

D-237

27 CIGARETTE LIGHTER, POWER OUTLET 27-1 RHD VEHICLE

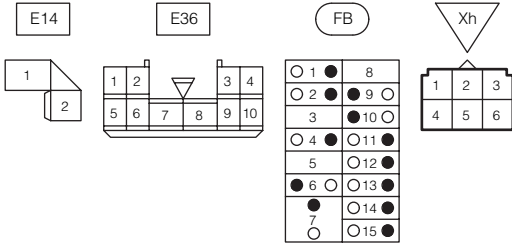
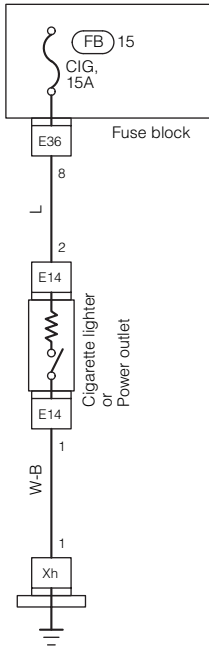

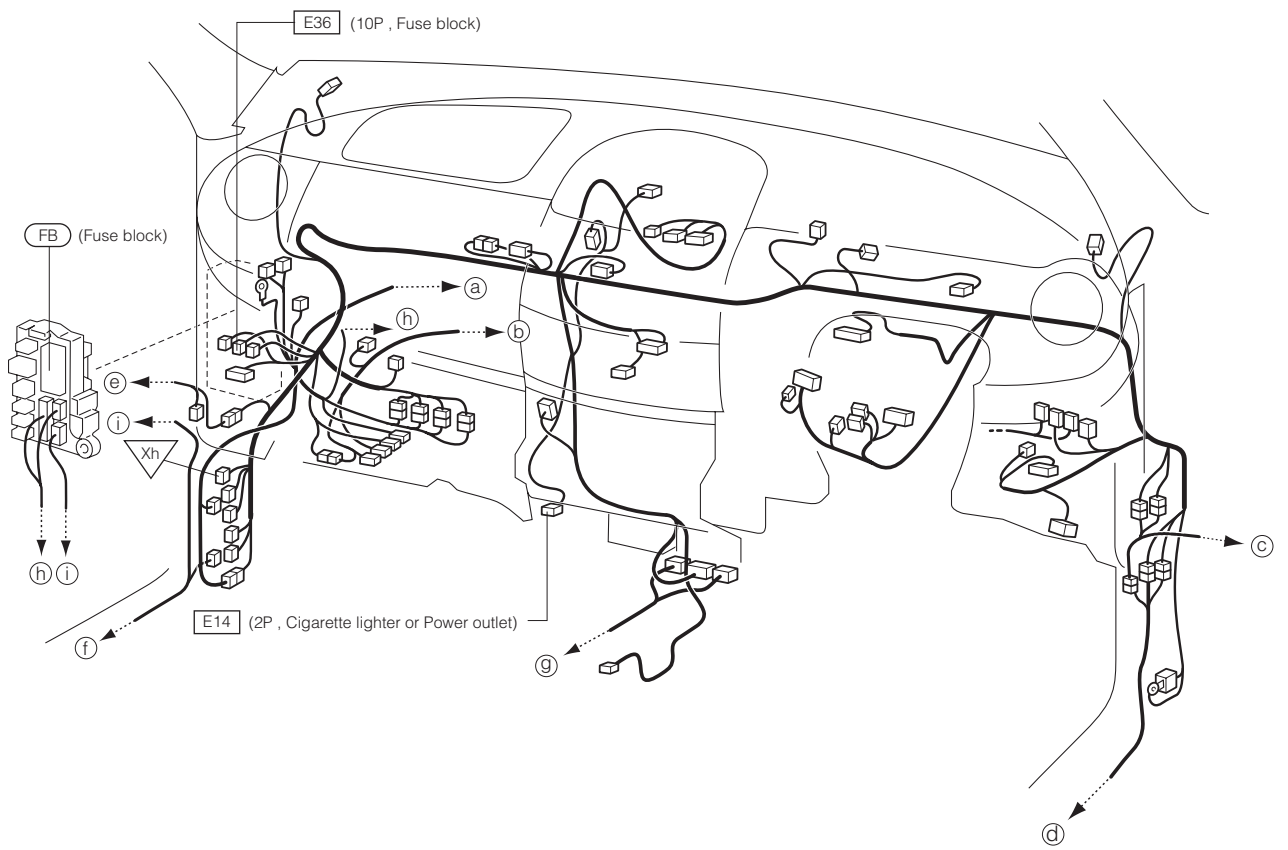

27-2 LHD VEHICLE

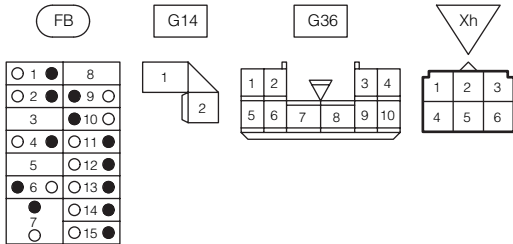
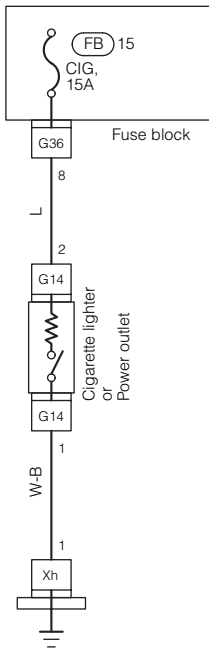

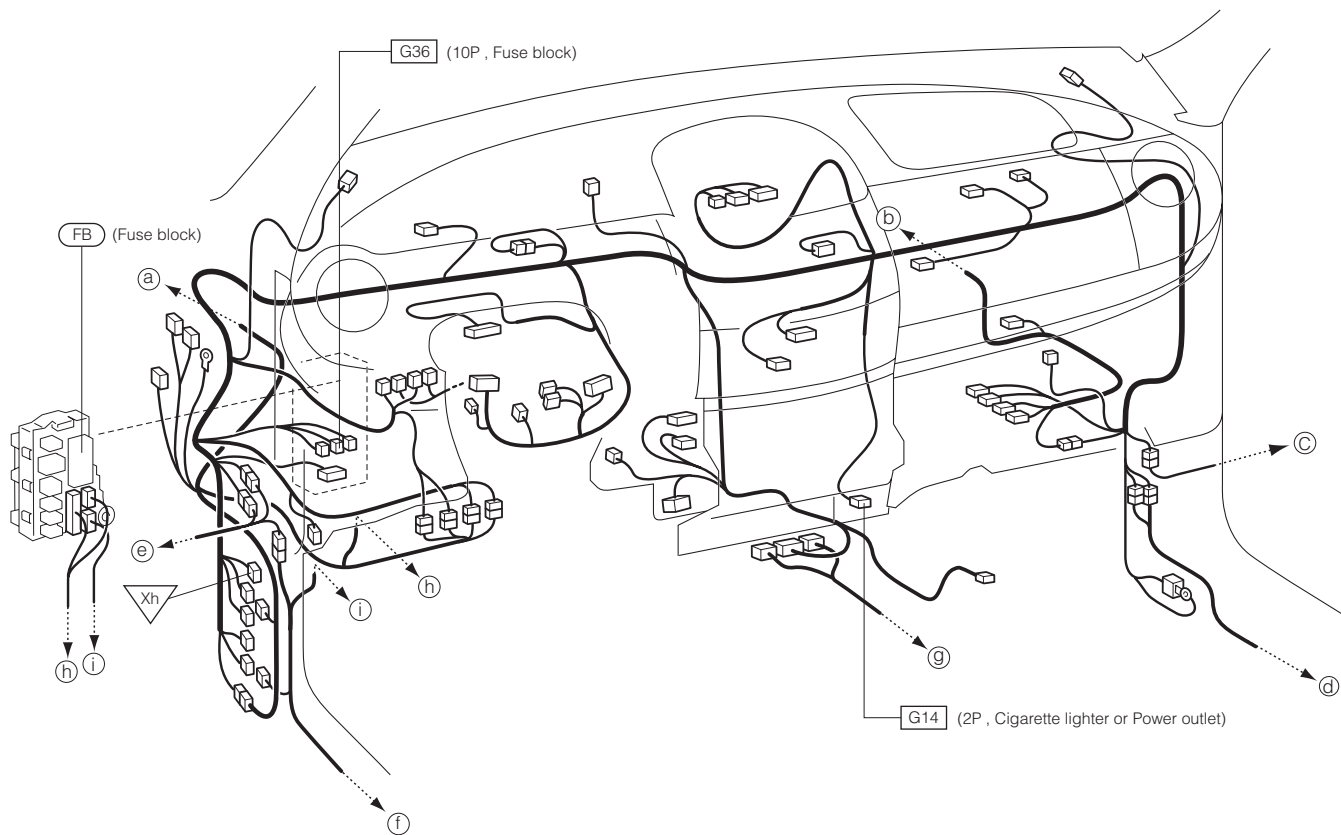

D-241

28 HEATER & AIR CONDITIONER 28-1 RHD VEHICLE

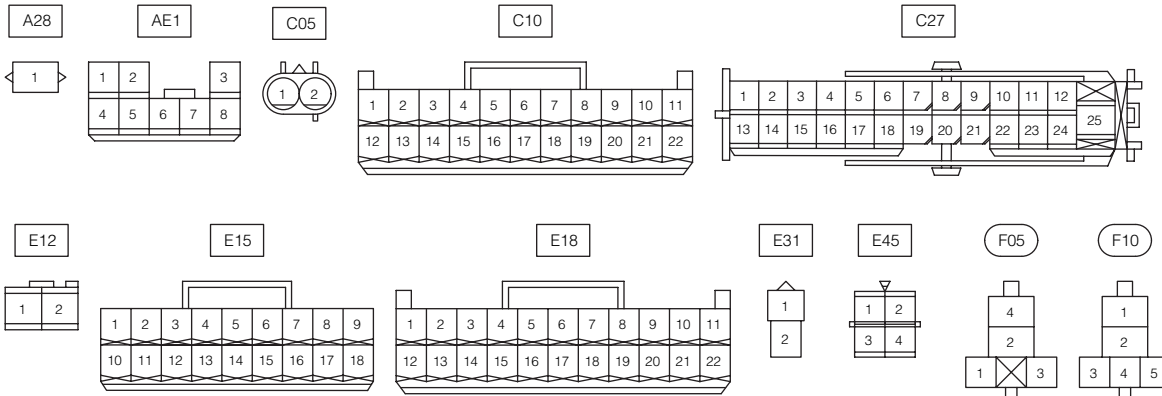
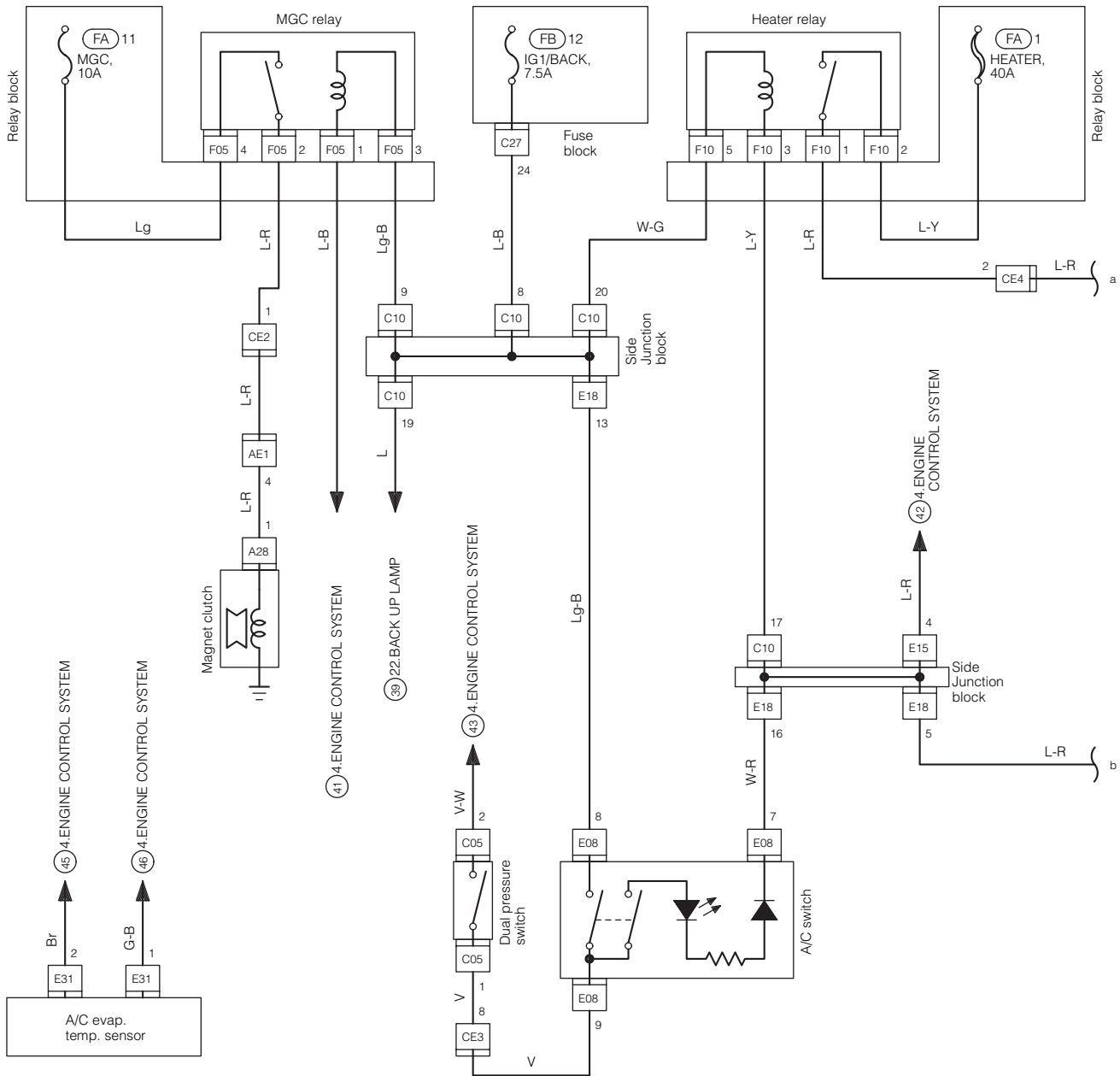

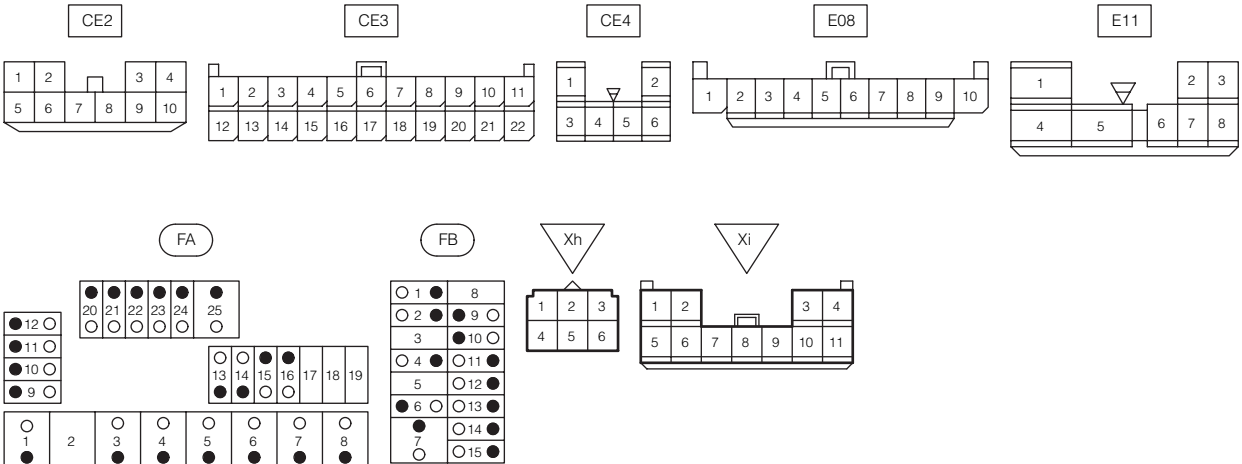
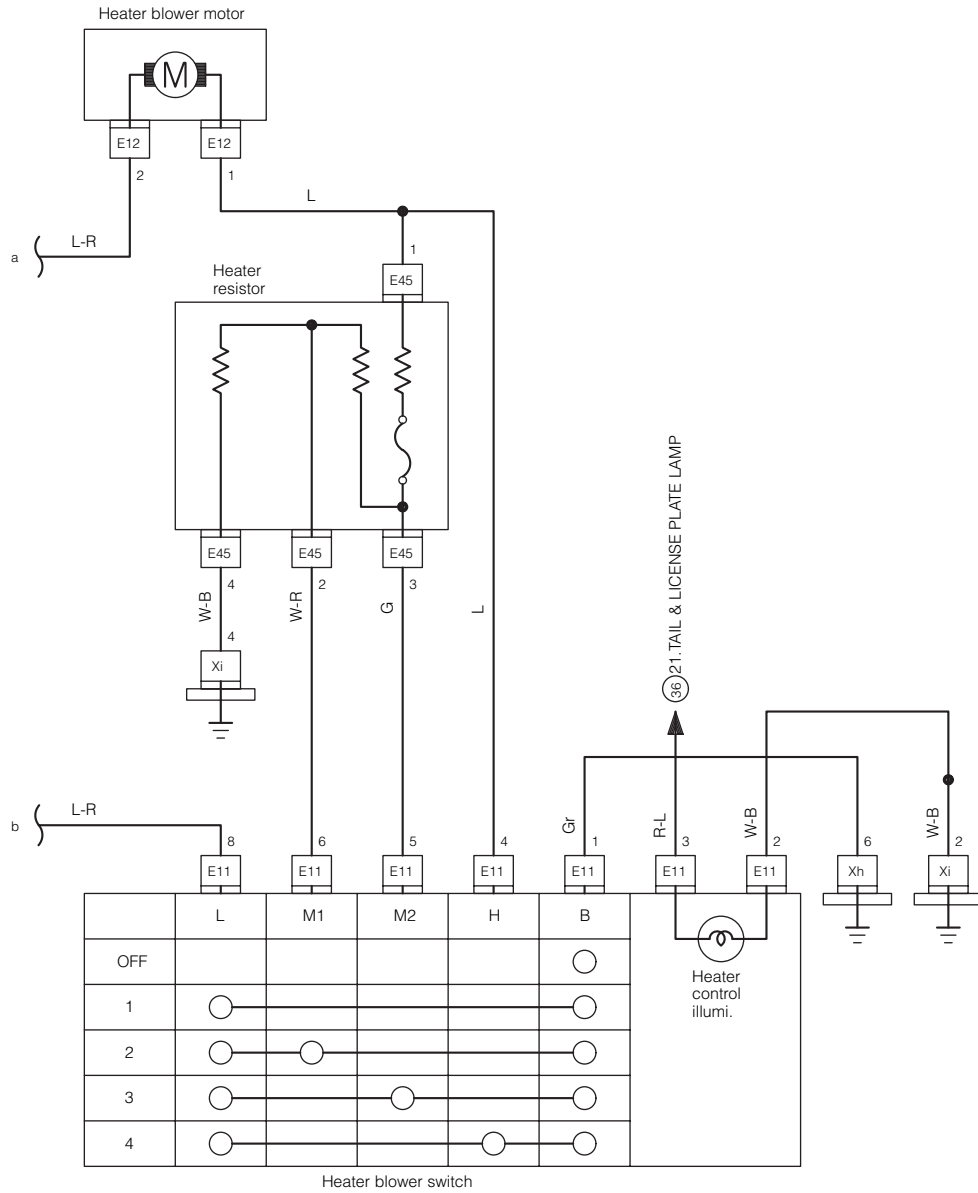

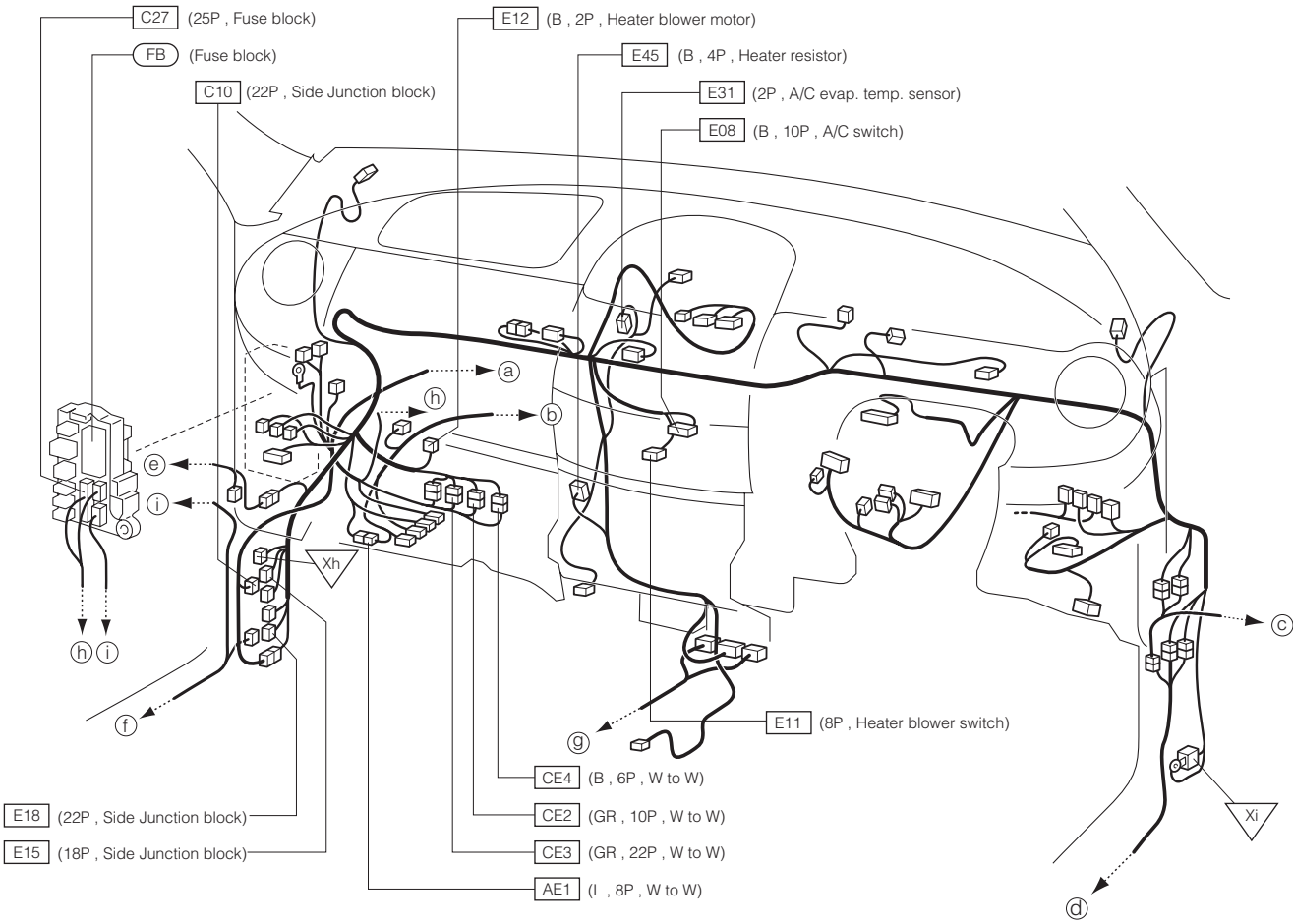

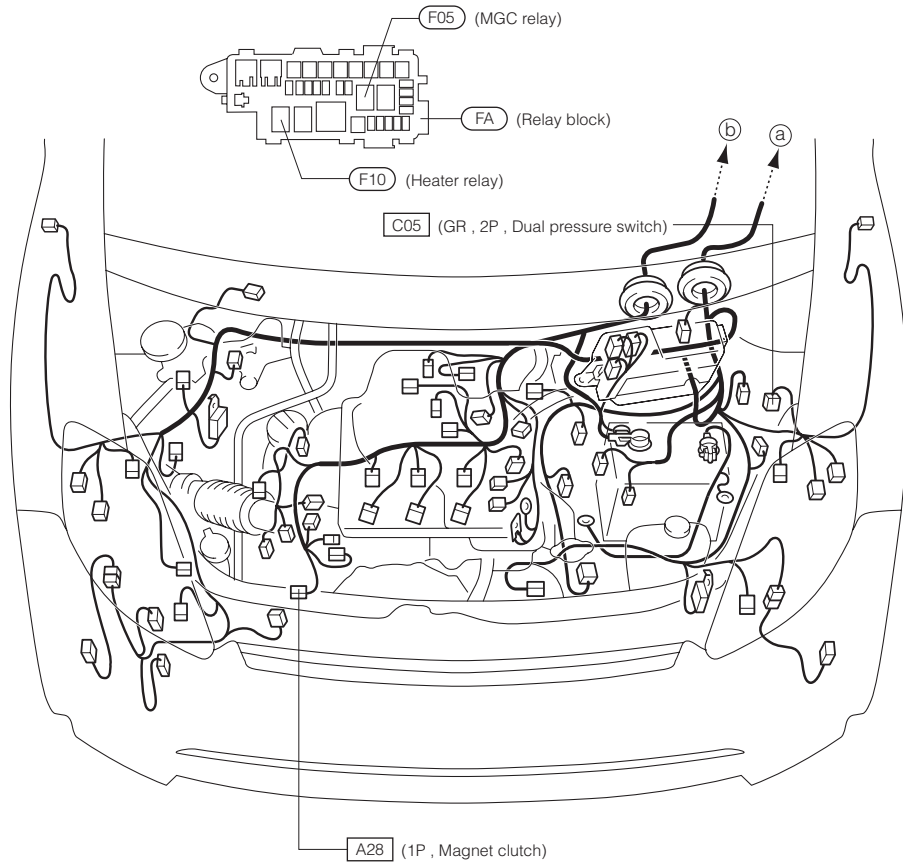

28-2 LHD VEHICLE

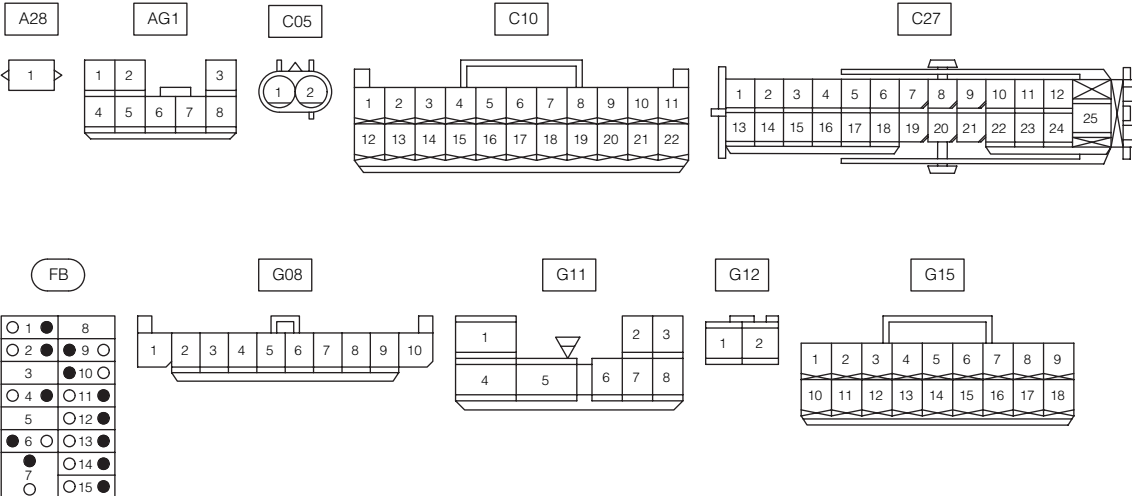
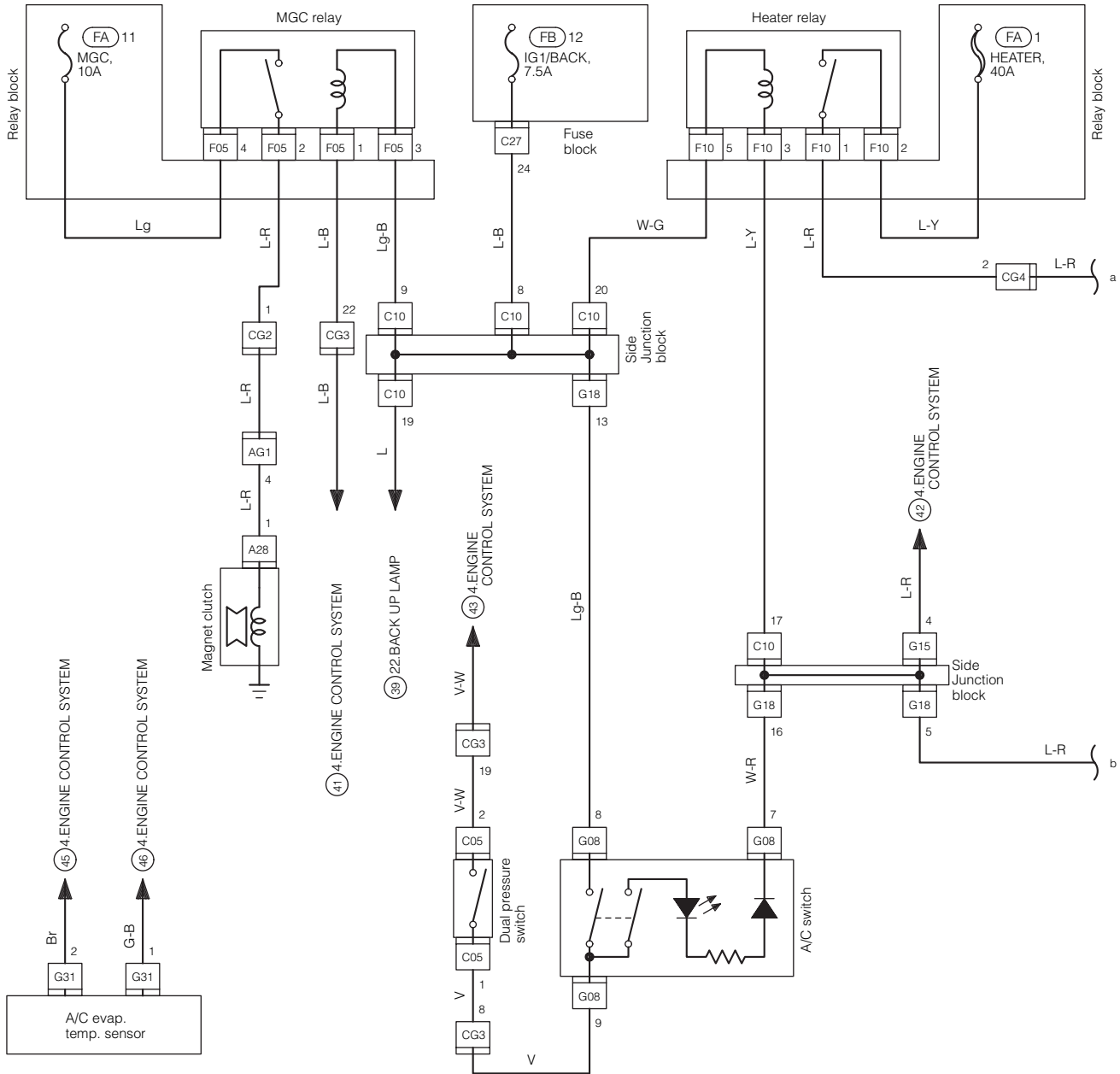

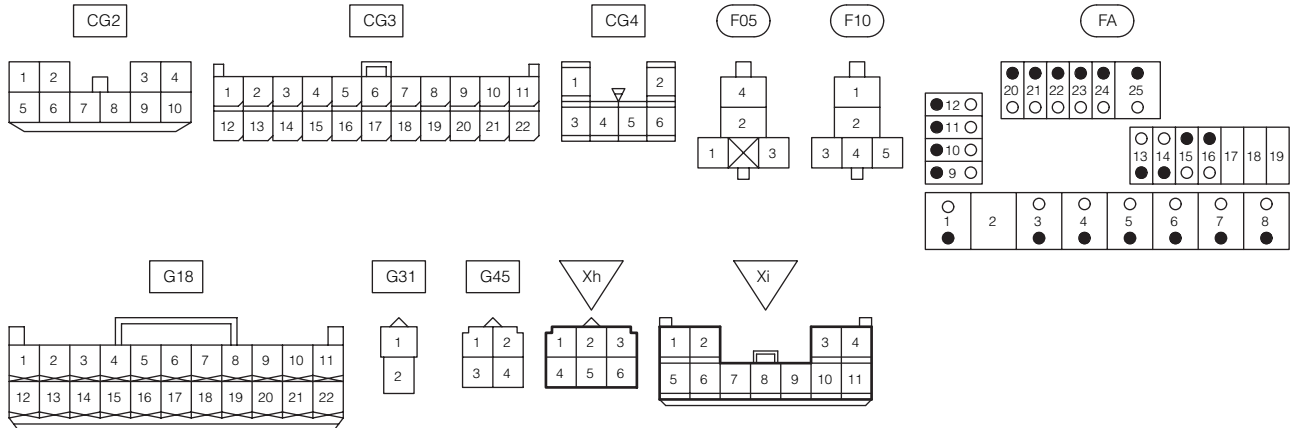
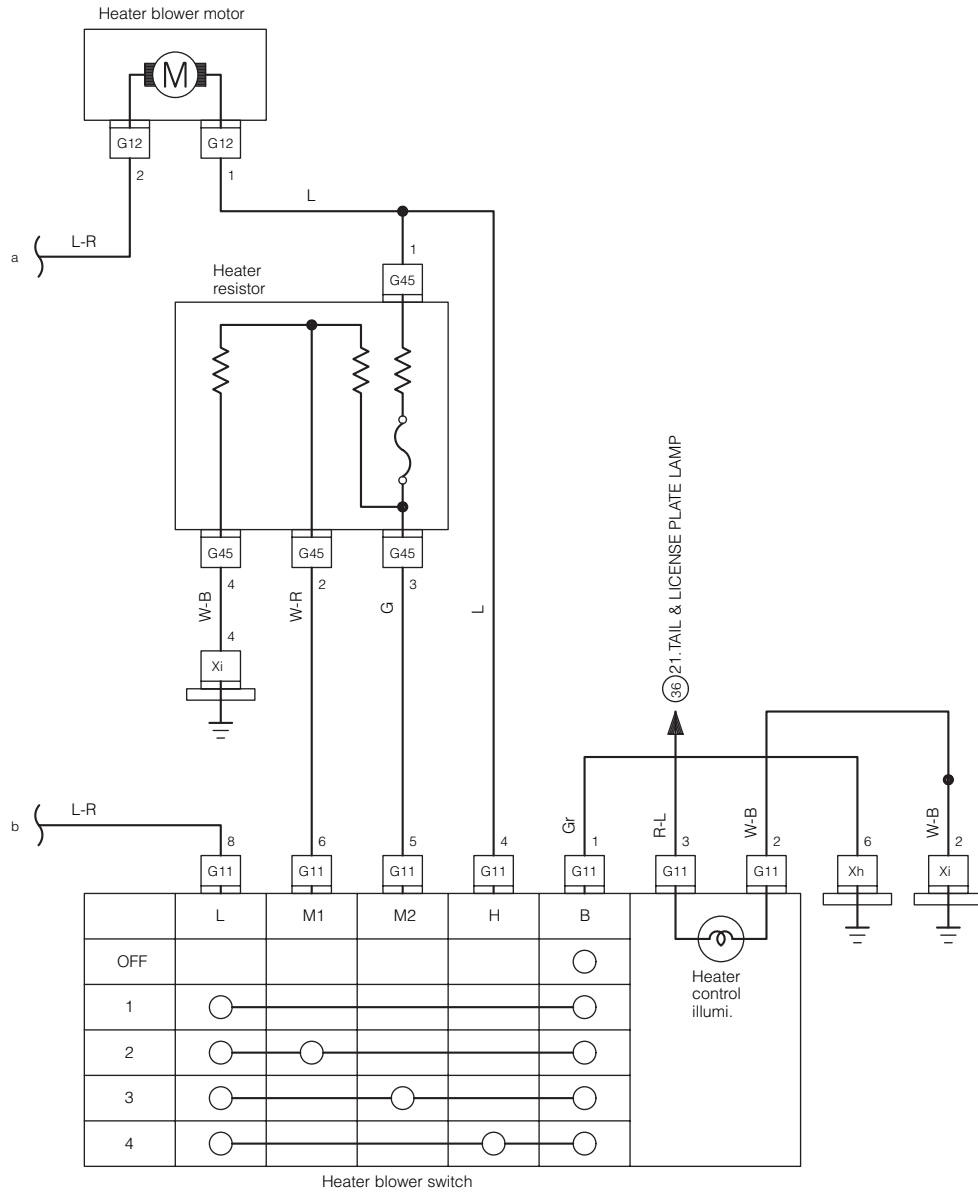

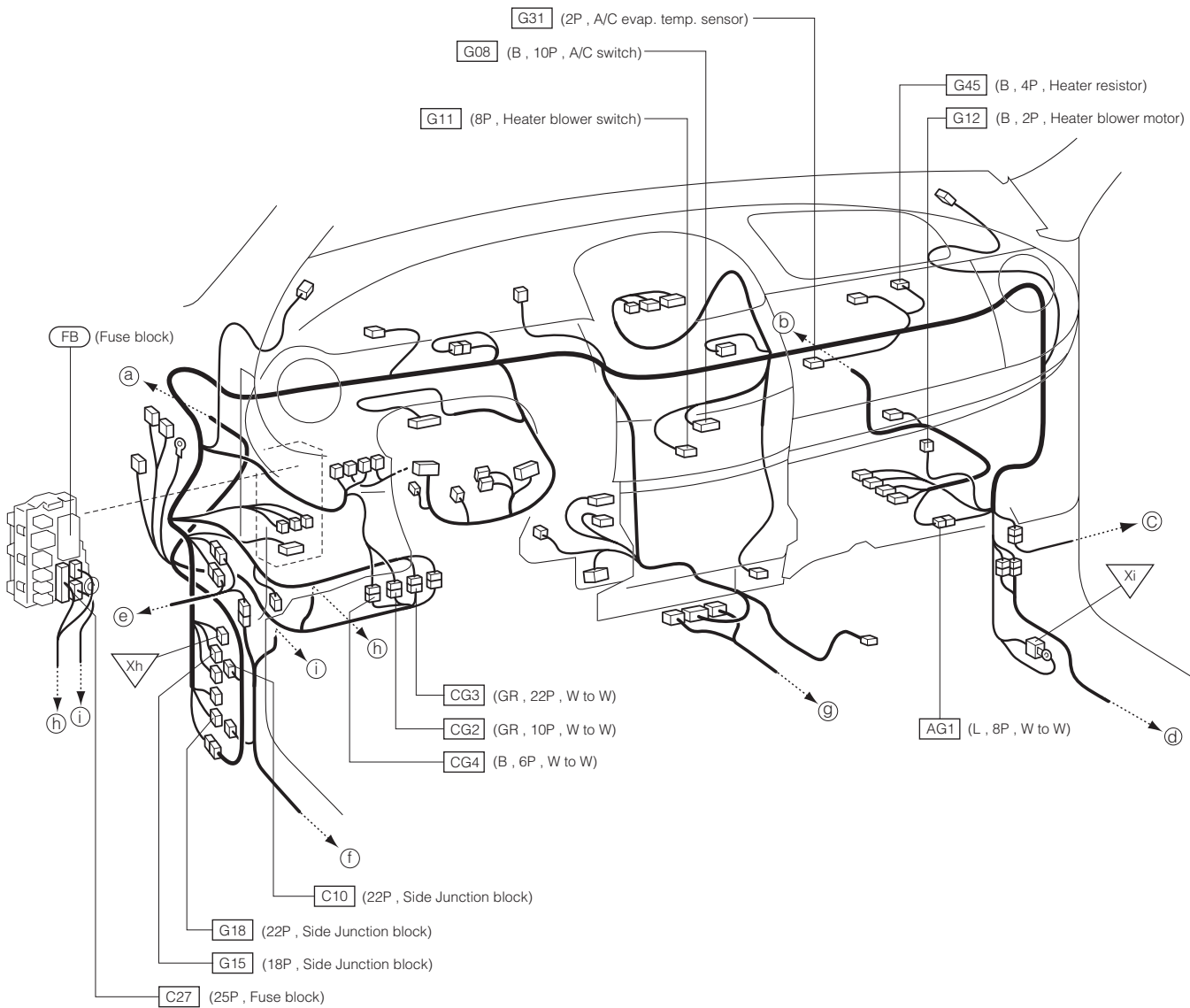

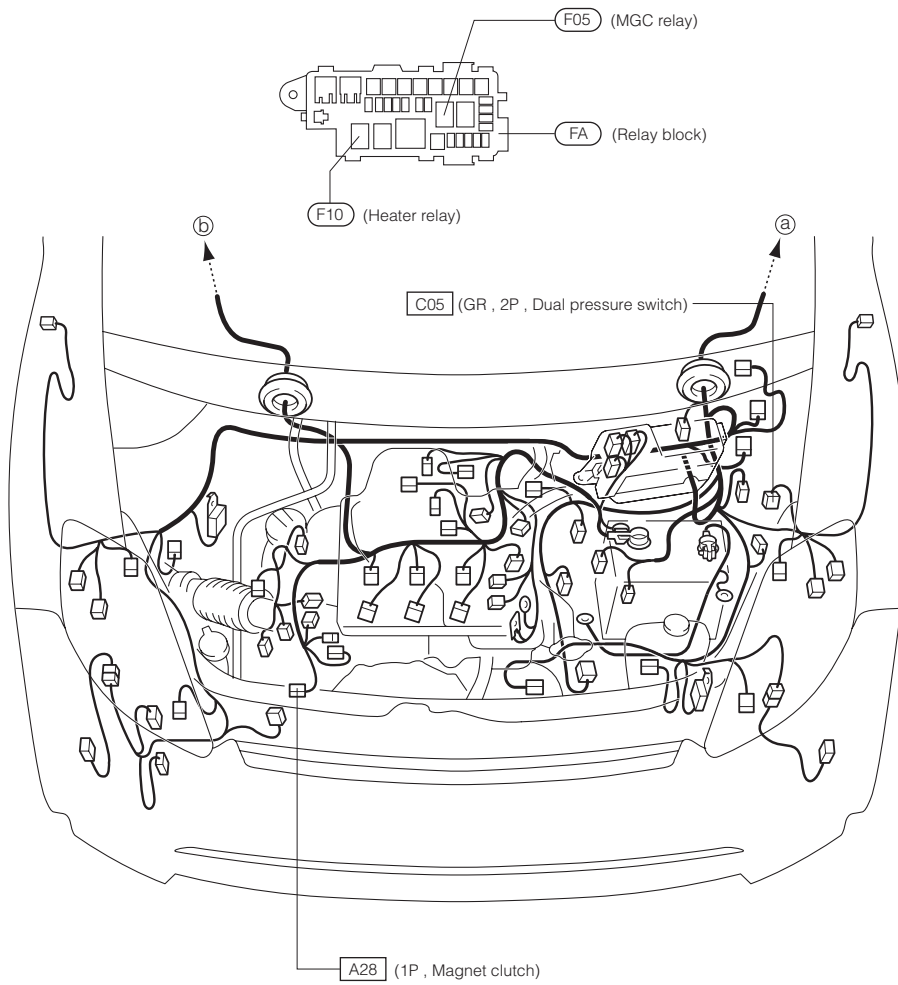

29 DATA LINK CONNECTOR 29-1 RHD VEHICLE

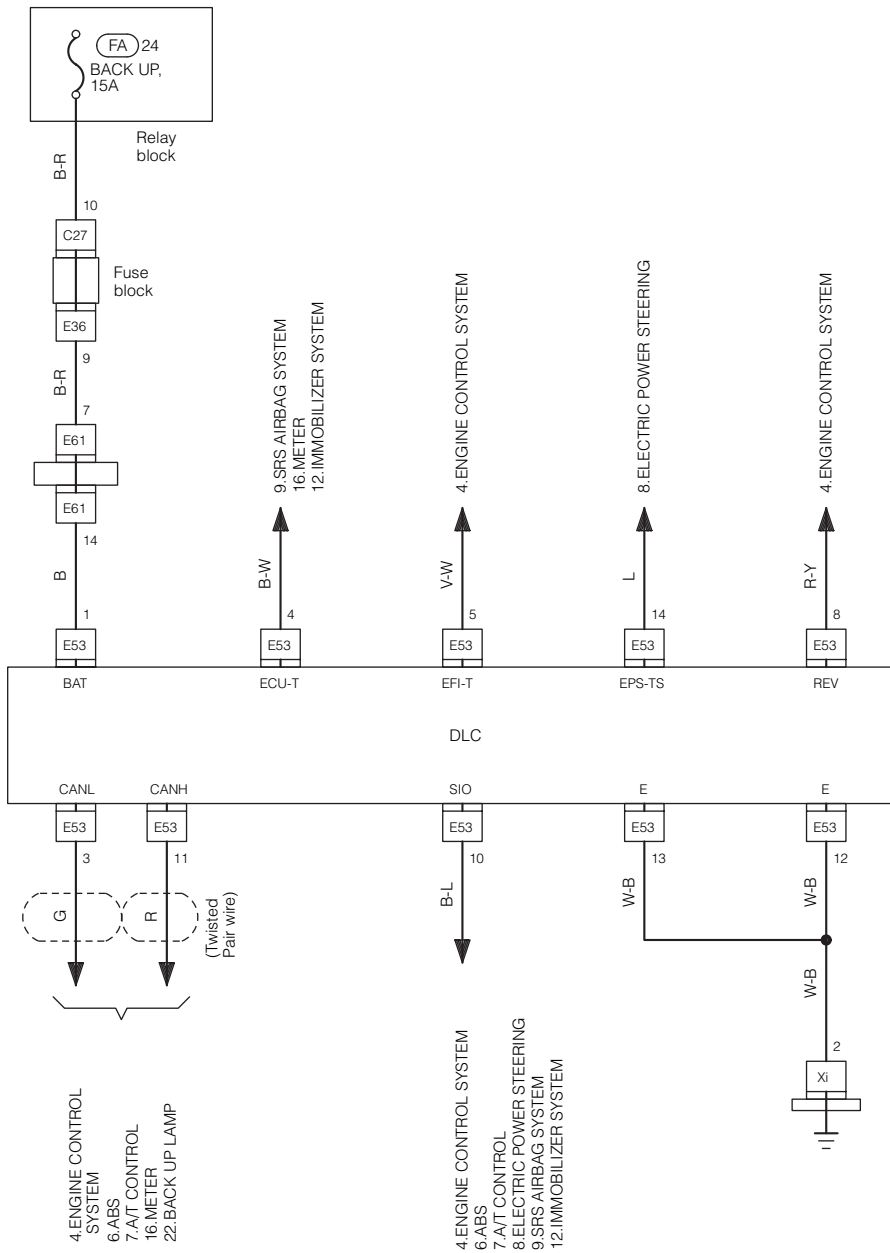

C27

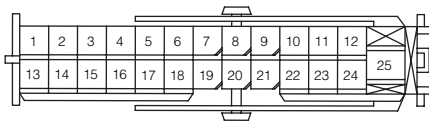

E36

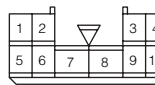

E53

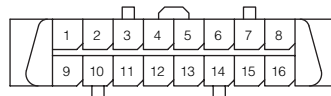

E61



FA

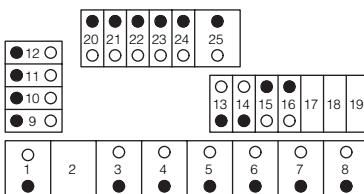

Xi

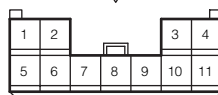

(MEMO)

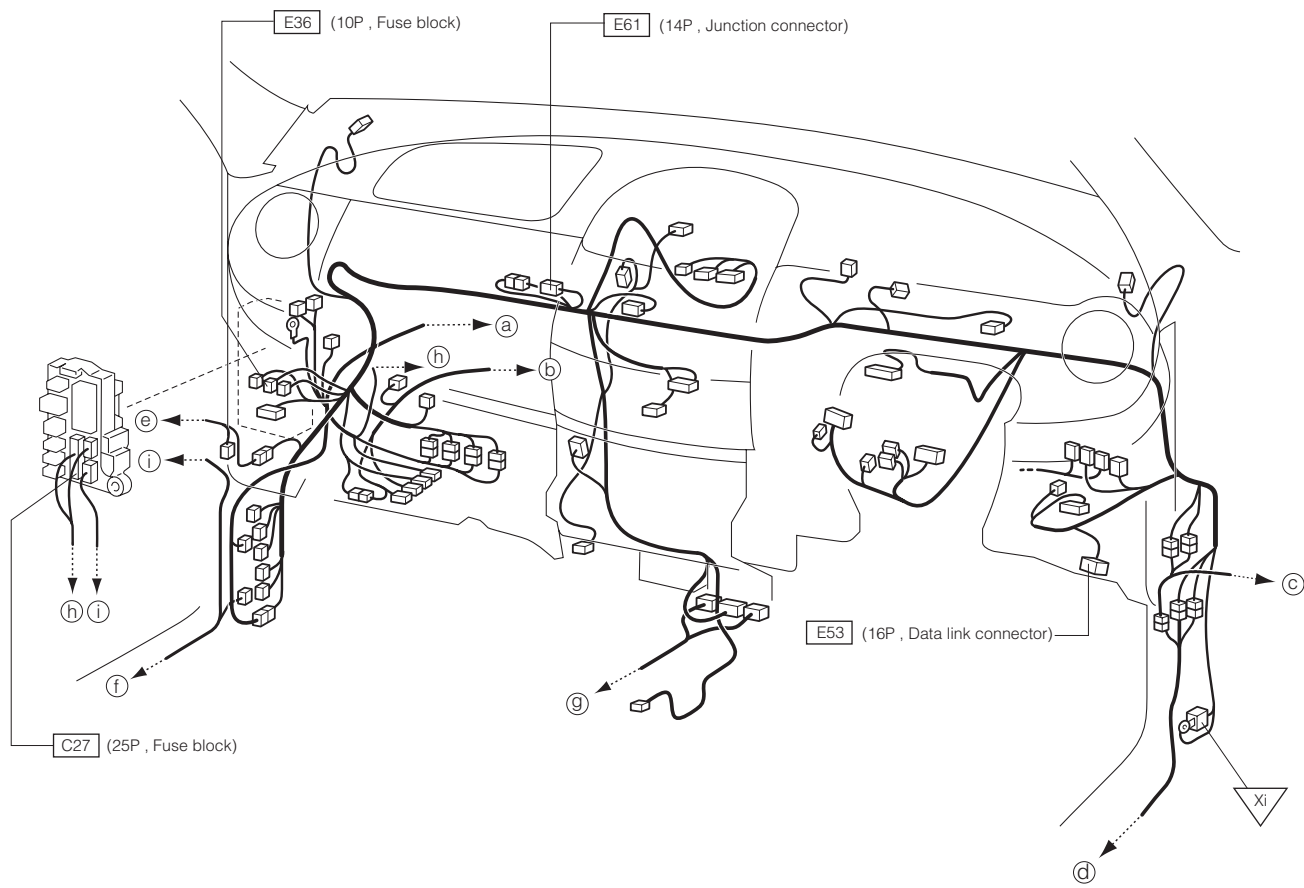

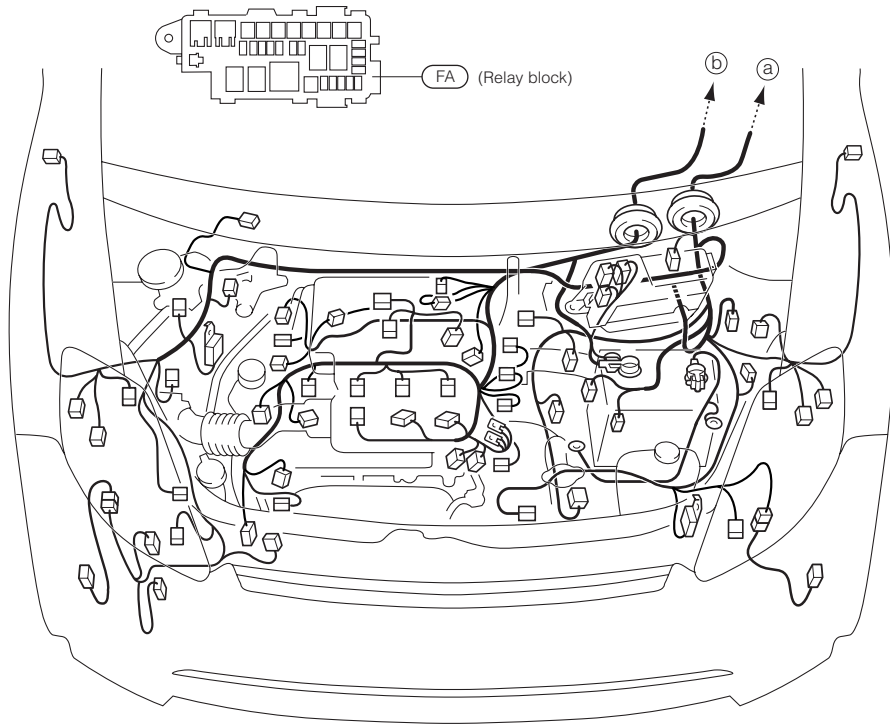

29-2 LHD VEHICLE

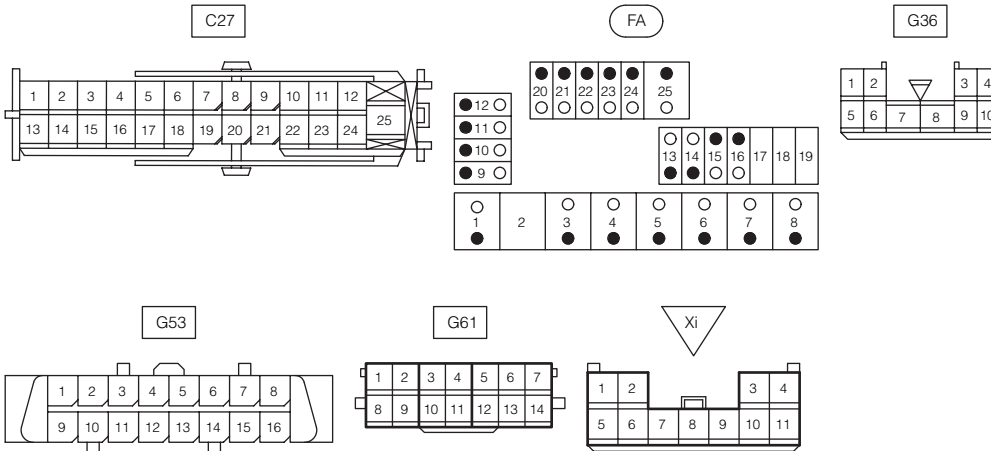
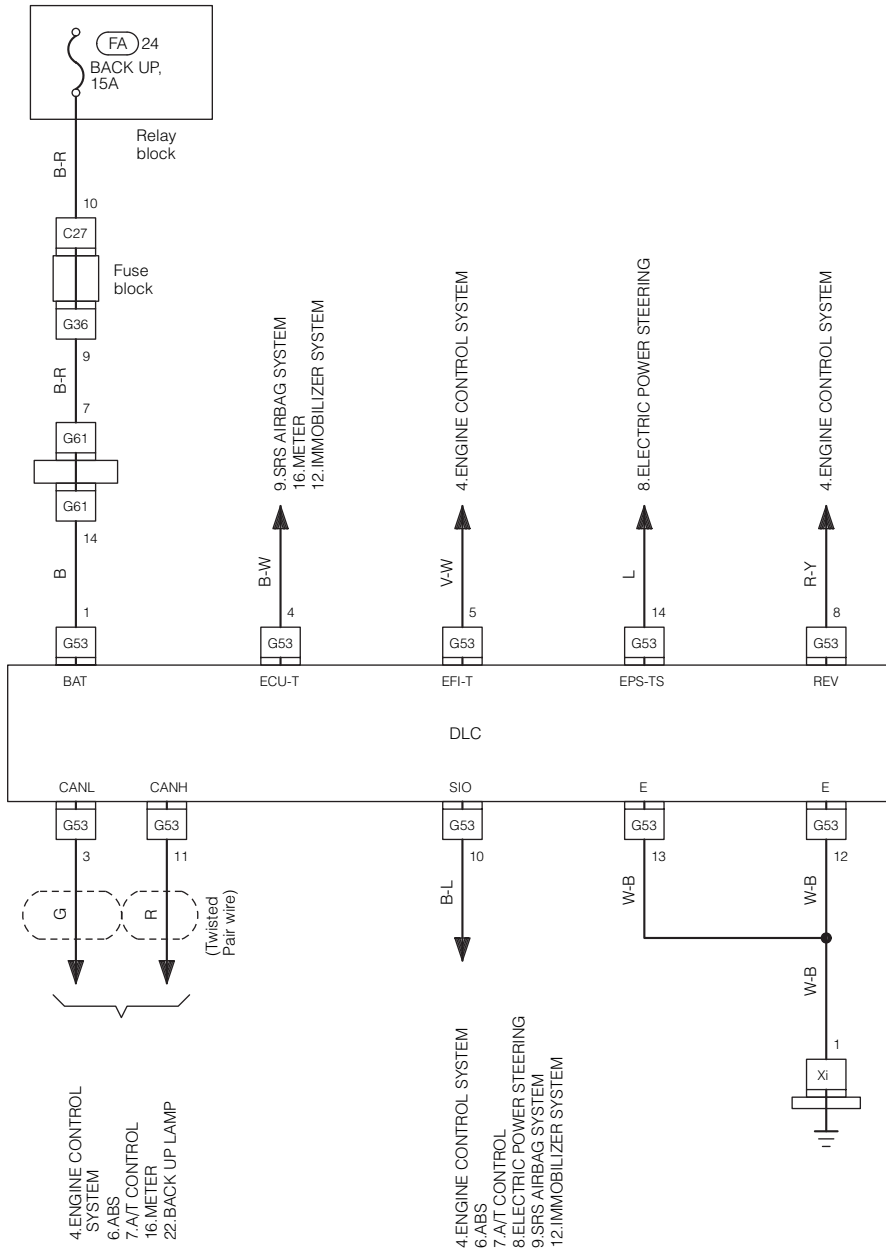

(MEMO)

